



Distr.: General  
21 October 2015

Original: English



**United Nations  
Environment  
Programme**

---

**Intergovernmental negotiating committee  
to prepare a global legally binding instrument  
on mercury  
Seventh session  
Dead Sea, Jordan, 10–15 March 2016  
Item 3 (b) of the provisional agenda\***

**Work to prepare for the entry into force of the Minamata  
Convention on Mercury and for the first meeting of the  
Conference of the Parties to the Convention: matters  
required by the Convention to be decided upon by the  
Conference of the Parties at its first meeting**

**Report of the group of technical experts on the development of  
guidance required under article 8 of the Convention**

**Draft guidance on best available techniques and best environmental practices**

**Note by the secretariat**

1. The secretariat has the honour to provide, in the annexes to the present note, the draft guidance prepared by the group of technical experts on air emissions and forwarded to the intergovernmental negotiating committee as the result of its work.
2. The guidance, which has not been formally edited, is set out in the annexes as follows:
  - (a) Annex I: Introduction;
  - (b) Annex II: Common techniques;
  - (c) Annex III: Monitoring;
  - (d) Annex IV: Coal-fired power plants and coal-fired industrial boilers;
  - (e) Annex V: Smelting and roasting processes used in the production of non-ferrous metals (lead, zinc, copper and industrial gold as specified in annex D to the Convention);
  - (f) Annex VI: Waste incineration facilities;
  - (g) Annex VII: Cement clinker production facilities.

---

\* UNEP(DTIE)/Hg/INC.7/1.

## Annex I

### Introduction

### Contents

1	Introduction .....	3
1.1	Purpose of document .....	3
1.2	Structure of the guidance .....	3
1.3	Chemical forms of mercury .....	3
1.4	Why are we concerned about mercury emissions? .....	3
1.5	Sources of mercury emissions covered by this guidance .....	4
1.6	Relevant provisions of the Minamata Convention.....	4
1.7	Considerations in selecting and implementing BAT .....	7
1.8	Performance levels.....	7
1.9	Best environmental practices .....	7
1.10	Cross-media effects .....	8
1.11	Multi-pollutant control techniques.....	8
1.12	Other international agreements.....	8
1.12.1 ...	Basel Convention on the Control of Transboundary Movements of Hazardous Wastes and their Disposal.....	8
1.12.2	Convention on Long-range Transboundary Air Pollution .....	8
1.13	UNEP Global Mercury Partnership .....	9

# 1 Introduction

## 1.1 Purpose of document

This document presents guidance related to best available techniques (BAT) and best environmental practices (BEP) to assist parties in fulfilling their obligations under Article 8 of the Minamata Convention on Mercury (hereinafter referred to as “the Convention”), which concerns controlling and, where feasible, reducing emissions of mercury and mercury compounds to the atmosphere from the point sources falling within the source categories listed in Annex D to the Convention. The guidance has been prepared and adopted as required by Article 8.

## 1.2 Structure of the guidance

The guidance is arranged in seven chapters. The present introductory chapter includes general information on the challenges of mercury and the provisions of the Convention, in particular those relevant to mercury emissions to air. It also provides some cross-cutting information, including considerations in selecting and implementing BAT and BEP.

Chapter 2 provides general information on common emission control techniques generally applicable to all the source categories covered by Article 8, and chapter 3 provides information on common elements of monitoring mercury emissions to the atmosphere from these sources.

Chapters 4, 5, 6 and 7 address the source categories listed in Annex D. Each source category is presented in an individual chapter, although guidance on coal-fired power plants and coal-fired industrial boilers is presented in a single chapter, given the similarities in the processes and applicable controls.

Additional information, in the form of case studies, is also available as a separate document, although these case studies do not form part of the formal guidance.

## 1.3 Chemical forms of mercury

Mercury is an element, but may be found in different chemical forms. The Convention deals with both elemental mercury and compounds of mercury, but only where mercury and its compounds are anthropogenically emitted or released.<sup>1</sup> Inorganic mercury compounds include oxides, sulfides or chlorides, for example. In this guidance, “mercury” refers to both elemental mercury and mercury compounds unless the context makes it clear that a specific form is meant. This is consistent with the scope of Article 8 on emissions, which addresses controlling and, where feasible, reducing emissions of mercury and mercury compounds, often expressed as “total mercury”.

The chemical form of mercury emissions from the categories in Annex D varies depending on source type and other factors. Gaseous elemental mercury is the most common in anthropogenic emissions to the atmosphere (UNEP, 2013). The remaining emissions are in the form of gaseous oxidized mercury or as mercury bound to emitted particles. These forms have a shorter atmospheric lifetime than gaseous elemental mercury and are deposited to land or water bodies more rapidly after their release (UNEP, Global Mercury Assessment, 2003). Elemental mercury in the atmosphere can undergo transformation into oxidized mercury that is more readily deposited.

Mercury can also be found in organic compounds – for example methyl or ethyl mercury, which are the most toxic forms. Organic compounds of mercury are not emitted by the sources covered by Article 8 of the Convention, but elemental or oxidized mercury, once deposited, can be transformed under certain circumstances into organic compounds by bacteria in the environment.

## 1.4 Why are we concerned about mercury emissions?

Mercury has been recognized as a chemical of global concern, owing to its long-range atmospheric transport, its persistence in the environment, its ability to bioaccumulate in ecosystems and its significant negative effects on human health and the environment.<sup>2</sup>

Mercury is toxic to the central and peripheral nervous systems at high concentrations, in both elemental and organic forms, and inhaling mercury vapour can produce harmful effects on the nervous, digestive and immune systems, lungs and kidneys. Even at lower concentrations, organic compounds of mercury can affect developing organs, such as the foetal nervous system. Mercury is also widely found in many ecosystems – elevated levels have been measured in numerous freshwater and marine fish species throughout the world. Mercury is bioaccumulative, and is therefore found in higher concentrations in organisms at the top of the food chain.<sup>3</sup> The majority of human exposure occurs through eating fish.

---

<sup>1</sup> See Convention text, article 1 and article 2

<sup>2</sup> For example, in the preamble to the Convention.

<sup>3</sup> Further information about the health effects of mercury may be found at: <http://www.who.int/mediacentre/factsheets/fs361/en>.

The most significant anthropogenic releases of mercury globally are through emissions to air, but mercury is also released from various sources directly to water and land. Once in the environment mercury persists and circulates in various forms between air, water, sediments, soil and biota. Emissions and releases from virtually any local source add to the global pool of mercury that is continuously mobilized, deposited on land and water, and remobilized. Rivers and ocean currents are also media for long-range transport. Even countries with minimal mercury releases, and areas remote from industrial activity, may be adversely affected. For example, high mercury levels are observed in the Arctic,<sup>4</sup> far from the sources of any significant releases.

Implementing measures to control or reduce mercury emissions can be expected to realize clear benefits in terms of public health, and for the environment. These benefits have an economic value. Quantified estimates have been made in some countries and regions of the scale of these benefits,<sup>5</sup> but it is very difficult to make any global estimate of the value of these benefits in monetary terms. Nevertheless, their value is likely to be considerable.

Implementing measures to control mercury emissions will, however, usually involve some cost. There may be either capital costs in installing control technologies, or increased costs in operating and maintaining facilities, or both. The chapters on each of the source categories give examples of these costs for particular facilities, where reliable information is available. The actual costs, however, are likely to depend on the specific circumstances of a facility; thus, the figures quoted should be taken only as a broad indication of the likely scale of costs. For any particular case, specific information will need to be obtained for that particular facility. It is recognized that these costs will generally fall to the operator of the specific facility, while the benefits described above accrue to society in general.

### **1.5 Sources of mercury emissions covered by this guidance**

The Convention is concerned only with anthropogenic emissions and releases of mercury (naturally occurring sources, such as volcanoes, are outside its scope), and Article 8 deals with five specific source categories that are listed in Annex D to the Convention. The initial list contains coal-fired power plants, coal-fired industrial boilers, smelting and roasting processes used in the production of non-ferrous metals,<sup>6</sup> waste incineration facilities, and cement clinker production facilities. Chapters 4, 5, 6 and 7 describe these processes in detail. Mercury may be emitted from these sources if it is present in the fuels and raw materials used in the associated processes, or in the waste burned in incineration plants.

Emissions to the atmosphere also arise from other sources not listed in Annex D – such as artisanal and small-scale gold mining, which is probably the biggest single source of emissions, or from industrial processes in which mercury is used as part of the process, for example as a catalyst. Other articles of the Convention deal with these sources and they are not covered by the present guidance.

The 2013 UNEP Global Mercury Assessment provides estimates of anthropogenic mercury emissions to the atmosphere. The categories used in that assessment do not, however, correspond exactly to those set out in Annex D.

### **1.6 Relevant provisions of the Minamata Convention**

The Convention deals with all aspects of the life cycle of anthropogenic mercury, and its provisions need to be considered as a whole.

There are provisions on mercury supply sources and trade; mercury-added products and manufacturing processes using mercury; artisanal and small-scale gold mining; emissions and releases; environmentally sound interim storage of mercury; mercury wastes; and contaminated sites. There are also provisions on monitoring, inventories, reporting by parties, information exchange, public information, awareness and education, research, development and monitoring, and health aspects. There are also provisions relating to financial resources and capacity-building, technical assistance and technology transfer.

Article 2 of the Convention sets out the following definitions of mercury and mercury compounds, and of best available techniques and best environmental practices:

“(b) ‘Best available techniques’ means those techniques that are the most effective to prevent and, where that is not practicable, to reduce emissions and releases of mercury to air, water and land and the impact of such emissions and releases on the environment as a whole, taking into account economic and technical considerations for a given Party or a given facility within the territory of that Party. In this context:

---

<sup>4</sup> UNEP (2013) Global Mercury Assessment

<sup>5</sup> For example, K. Sundseth, J.M. Pacyna, E.G. Pacyna M. Belhaj and S. Astrom. (2010). Economic benefits from decreased mercury emissions: Projections for 2020. *Journal of Cleaner Production*. 18: 386–394 .

<sup>6</sup> For these purposes, “non-ferrous metals” refers to lead, zinc, copper and industrial gold.

“‘Best’ means most effective in achieving a high general level of protection of the environment as a whole;

“‘Available’ techniques means, in respect of a given Party and a given facility within the territory of that Party, those techniques developed on a scale that allows implementation in a relevant industrial sector under economically and technically viable conditions, taking into consideration the costs and benefits, whether or not those techniques are used or developed within the territory of that Party, provided that they are accessible to the operator of the facility as determined by that Party; and

“‘Techniques’ means technologies used, operational practices and the ways in which installations are designed, built, maintained, operated and decommissioned;

“(c) ‘Best environmental practices’ means the application of the most appropriate combination of environmental control measures and strategies;

“(d) ‘Mercury’ means elemental mercury (Hg(0), CAS No. 7439-97-6);

“(e) ‘Mercury compound’ means any substance consisting of atoms of mercury and one or more atoms of other chemical elements that can be separated into different components only by chemical reactions”.

Paragraphs 1–6 of Article 8 of the Convention and its Annex D are reproduced below.

## **Article 8**

### **Emissions**

1. This Article concerns controlling and, where feasible, reducing emissions of mercury and mercury compounds, often expressed as “total mercury”, to the atmosphere through measures to control emissions from the point sources falling within the source categories listed in Annex D.

2. For the purposes of this Article:

(a) “Emissions” means emissions of mercury or mercury compounds to the atmosphere;

(b) “Relevant source” means a source falling within one of the source categories listed in Annex D. A Party may, if it chooses, establish criteria to identify the sources covered within a source category listed in Annex D so long as those criteria for any category include at least 75 per cent of the emissions from that category;

(c) “New source” means any relevant source within a category listed in Annex D, the construction or substantial modification of which is commenced at least one year after the date of:

(i) Entry into force of this Convention for the Party concerned; or

(ii) Entry into force for the Party concerned of an amendment to Annex D where the source becomes subject to the provisions of this Convention only by virtue of that amendment;

(d) “Substantial modification” means modification of a relevant source that results in a significant increase in emissions, excluding any change in emissions resulting from by-product recovery. It shall be a matter for the Party to decide whether a modification is substantial or not;

(e) “Existing source” means any relevant source that is not a new source;

(f) “Emission limit value” means a limit on the concentration, mass or emission rate of mercury or mercury compounds, often expressed as “total mercury”, emitted from a point source.

3. A Party with relevant sources shall take measures to control emissions and may prepare a national plan setting out the measures to be taken to control emissions and its expected targets, goals and outcomes. Any plan shall be submitted to the Conference of the Parties within four years of the date of entry into force of the Convention for that Party. If a Party develops an implementation plan in accordance with Article 20, the Party may include in it the plan prepared pursuant to this paragraph.

4. For its new sources, each Party shall require the use of best available techniques and best environmental practices to control and, where feasible, reduce emissions, as soon as practicable but no later than five years after the date of entry into force of the Convention for that Party. A Party may use emission limit values that are consistent with the application of best available techniques.

5. For its existing sources, each Party shall include in any national plan, and shall implement, one or more of the following measures, taking into account its national circumstances, and the economic and technical feasibility and affordability of the measures, as soon as practicable but no more than ten years after the date of entry into force of the Convention for it:

- (a) A quantified goal for controlling and, where feasible, reducing emissions from relevant sources;
  - (b) Emission limit values for controlling and, where feasible, reducing emissions from relevant sources;
  - (c) The use of best available techniques and best environmental practices to control emissions from relevant sources;
  - (d) A multi-pollutant control strategy that would deliver co-benefits for control of mercury emissions;
  - (e) Alternative measures to reduce emissions from relevant sources.
6. Parties may apply the same measures to all relevant existing sources or may adopt different measures in respect of different source categories. The objective shall be for those measures applied by a Party to achieve reasonable progress in reducing emissions over time.

#### **Annex D**

##### **List of point sources of emissions of mercury and mercury compounds to the atmosphere**

###### **Point source category:**

Coal-fired power plants;

Coal-fired industrial boilers;

Smelting and roasting processes used in the production of non-ferrous metals; 1/

Waste incineration facilities;

Cement clinker production facilities.

---

1/ For the purpose of this Annex, “non-ferrous metals” refers to lead, zinc, copper and industrial gold.

## 1.7 Considerations in selecting and implementing BAT

The definition of “best available techniques” in Article 2 of the Convention, and set out in section 1.6 above, forms the basis for the determination by a party of BAT for a facility within its territory.

The use of BAT to control and, where feasible, to reduce emissions is required for new sources as defined in paragraph 2 (c) of Article 8 and is one of several measures which a party may use for existing sources, as defined in paragraph 2 (e) of Article 8. A party may apply the same measures to all relevant existing sources or may adopt different measures in respect of different source categories. The present section is intended to support parties in selecting and implementing BAT.

The process for selecting and implementing BAT could be expected to include the following general steps.

- Step 1: establish information about the source, or source category. This may include, but not be limited to, information on the processes, input materials, feedstocks or fuels, and on the actual or expected activity levels, including throughput. Other relevant information could include the expected life of the facility, which is likely to be of particular relevance when an existing facility is being considered, and any requirements or plans for controlling other pollutants.
- Step 2: identify the full range of options of emission control techniques and combinations thereof which are relevant for the source under consideration, including the techniques described in the chapters of this guidance on common techniques and on specific source categories.
- Step 3: among these, identify technically viable control options, giving consideration to techniques applicable to the type of facility within the sector, and also to any physical limitations which may influence the choice of certain techniques.
- Step 4: from these, select the control technique options which are the most effective for the control and, where feasible, reduction of emissions of mercury, taking into account the performance levels mentioned in this guidance, and for the achievement of a high general level of protection of human health and the environment as a whole.
- Step 5: determine which of these options can be implemented under economically and technically viable conditions, taking into consideration costs and benefits and whether they are accessible to the operator of the facility as determined by the party concerned. Note that the options selected may differ for new and existing facilities. The need should also be taken into account for sound maintenance and operational control of the techniques, so as to maintain the achieved performance over time.

## 1.8 Performance levels

The individual chapters on each of the source categories include information about the performance levels which have been achieved in facilities operating the control techniques described in those chapters, where such information is available. This information is not intended to be interpreted as recommendations for emission limit values (ELVs). An “emission limit value” is defined in paragraph 2 (f) of Article 8 to mean “a limit on the concentration, mass or emission rate of mercury or mercury compounds, often expressed as ‘total mercury’, emitted from a point source.” Paragraph 4 of that Article provides that a party may control and, where feasible, reduce emissions from new sources by setting ELVs that are consistent with the application of BAT. Paragraph 5 of the Article includes ELVs in the list of measures, one or more of which parties may select for application to their existing sources. If a party chooses to use ELVs, it should consider similar factors to those described in the previous section in relation to the selection and implementation of BAT.

Guidance on how parties may choose to determine goals and set ELVs for existing sources under the Convention may be found in a separate document, entitled: “Guidance on support for Parties in implementing the measures set out in paragraph 5, in particular in determining goals and in setting emission limit values” (in preparations as at September 2015).

## 1.9 Best environmental practices

The Convention defines “best environmental practices” as “the application of the most appropriate combination of environmental control measures and strategies”.

Good maintenance of facilities and measurement equipment are important to the effective operation of control and monitoring techniques. Well-trained operators, who are aware of the need to pay attention to the processes, are indispensable to ensuring good performance. Careful planning and commitment from all levels within the organization operating the facility will also help to maintain performance, as will administrative controls and other facility management practices.

Information on BEP specific to each source category is provided in the respective chapters on those source categories.

## 1.10 Cross-media effects

Mercury emissions from the source categories listed in Annex D can be controlled or reduced using the techniques described in this guidance. Information on cross-media effects relevant to each source category is provided in the respective chapters on those source categories. The mercury that is removed from flue gases will appear elsewhere – for example, in solid phases such as fly ash or bottom ash, or in liquid or solid-liquid mixed phases such as sludge. Because mercury may be more concentrated in these materials than in input materials, care should be taken to avoid the potential for mercury release through leaching, or cross-media transfers of mercury and other constituents of concern resulting from the disposal of such residues, or from their use as components in other processes. In defining BAT/BEP at the national level, regulators should take into account these factors. Other articles of the Convention may be relevant, in particular Article 11, on mercury wastes.

## 1.11 Multi-pollutant control techniques

There are techniques that may be used to control the emissions of a range of pollutants, such as particulate matter, organic pollutants, SO<sub>x</sub> and NO<sub>x</sub>, and heavy metals, including mercury. Consideration should be given to the advantages of using techniques capable of controlling several pollutants simultaneously to deliver mercury co-benefits. In assessing these techniques, factors such as efficiency of mercury control, control of other pollutants, and any potential adverse consequences, such as reduced efficiency within the overall system or cross-media effects, should also be considered.

The use of a multi-pollutant control strategy that can deliver co-benefits for the control of mercury emissions is included in paragraph 5 of Article 8 as an option for managing emissions from existing sources.

## 1.12 Other international agreements

Parties to the Convention may also be parties to other relevant global or regional multilateral environmental agreements that may need to be considered alongside the Minamata Convention.

For example, the provisions of the Stockholm Convention on Persistent Organic Pollutants cover many of the same source categories as those listed in Annex D of the Minamata Convention, and countries which are parties to both conventions will therefore need to ensure that they also take account of any relevant provisions of that Convention.<sup>7</sup>

Two relevant agreements to which some parties to the Minamata Convention may also be parties are the Basel Convention on the Control of Transboundary Movements of Hazardous Wastes and Their Disposal, and the Convention on Long-range Transboundary Air Pollution adopted within the framework of the United Nations Economic Commission for Europe.

### 1.12.1 Basel Convention on the Control of Transboundary Movements of Hazardous Wastes and their Disposal

The goal of the Basel Convention is to protect human health and the environment from the adverse effects resulting from the generation, management, transboundary movements and disposal of hazardous and other wastes.

The implementation of measures to control and reduce mercury emissions can generate wastes that may be hazardous. The handling of these wastes is covered under Article 11 of the Minamata Convention, paragraph 3 of which requires parties to manage mercury wastes in an environmentally sound manner, taking into account the obligations and guidelines under the Basel Convention, and, for parties to the Basel Convention, not to transport mercury wastes across international boundaries except for the purpose of environmentally sound disposal in conformity with that Article and with the Basel Convention. The technical guidelines developed under the Basel Convention on waste management are relevant to the management of sludge and other wastes resulting from the capture of mercury from relevant sources, and could be valuable in minimizing or preventing cross-media effects which may result from poor management of such wastes.<sup>8</sup>

### 1.12.2 Convention on Long-range Transboundary Air Pollution

The aim of the Convention on Long-range Transboundary Air Pollution is to limit and, as far as possible, gradually reduce and prevent air pollution, including long-range transboundary air pollution, caused by a range of pollutants. Under the Convention, the Protocol on Heavy Metals was adopted in 1998 in Aarhus, Denmark, and entered into force in 2003. It targets three metals: cadmium, lead and mercury. The stationary source categories covered by the Protocol include the relevant sources listed in Annex D to the Minamata Convention.

---

<sup>7</sup> Detailed guidance on the use of BAT/BEP to meet the requirements of that Convention may be found at <http://chm.pops.int/Implementation/BATandBEP/Overview/tabid/371/Default.aspx>.

<sup>8</sup> The technical guidelines are available at <http://www.basel.int/Implementation/Publications/TechnicalGuidelines/tabid/2362/Default.aspx>.



One of the basic obligations assumed by parties to the Protocol on Heavy Metals is to reduce their emissions for these three metals below their levels in 1990 (or an alternative year between 1985 and 1995). The Protocol aims to reduce emissions of cadmium, lead and mercury from industrial sources (iron and steel industry, non-ferrous metal industry, cement manufacturing, glass manufacturing, chlor-alkali industry), combustion processes (power generation, industrial boilers) and waste incineration. It lays down stringent limit values for emissions from stationary sources and suggests BAT for these sources. The Protocol was amended in 2012 to introduce flexibilities to facilitate the accession of new parties, notably countries in Eastern Europe, the Caucasus and Central Asia. A guidance document on BAT for controlling emissions of heavy metals from the source categories covered by the Protocol was also adopted in 2012.

### **1.13 UNEP Global Mercury Partnership**

The UNEP Governing Council has called for partnerships between governments and other stakeholders as a means of reducing risks to human health and the environment from the release of mercury and its compounds to the environment.<sup>9</sup> The overall goal of the resulting Global Mercury Partnership is to protect human health and the global environment from the release of mercury and its compounds by minimizing and, where feasible, ultimately eliminating global, anthropogenic mercury releases to air, water and land.

The Partnership currently has eight identified priorities for action (or partnership areas), of which four are particularly relevant to the present guidance: mercury control from coal combustion; mercury waste management; mercury supply and storage; and mercury reduction from the cement industry.

Experience gained within these partnership areas, together with relevant guidance developed within the partnership, has been considered in the development of the present BAT/BEP guidelines.

Further information may be found at:

<http://www.unep.org/chemicalsandwaste/Mercury/GlobalMercuryPartnership/tabid/1253/Default.aspx>.

---

<sup>9</sup> UNEP Governing Council decision 23/9.

## Annex II

### Common techniques

#### Common techniques for emission reduction

This chapter provides general information on control techniques which are applicable across all the point source categories listed in Annex D. Additional information specifically relevant to the individual sectors may be found in the chapter pertaining to the sector in question.

In order to consider all possible options relevant to the sector of interest, it is necessary to consider both the common techniques described in this section and the specific techniques described for each sector.

Particle-bound emissions of mercury can be captured to a varying extent by dust-cleaning devices. Most of the dust-cleaning techniques are generally applied in all sectors. The degree of mercury control depends on the chemical state and form of the mercury, e.g., whether oxidized or elemental. Elemental mercury is mostly not captured in dust-cleaning devices: the mercury-removal efficiency of these devices can be enhanced by oxidizing the gaseous mercury. The most commonly used techniques for dust abatement are bag filters and electrostatic precipitators (ESP).

A common technique across sectors for specific mercury removal is to use activated carbon, either injected into the flue-gas stream or in a filter bed. To improve the removal efficiency of the activated carbon oxidizing agents can be used (e.g. injected in the flue-gas stream or adsorbed on the activated carbon).

##### *Fabric filters*

Bag filters (fabric filters, textile filters) use filtration to separate dust particulates from gases. They represent one of the most efficient and cost-effective types of dust collectors available and can achieve a collection efficiency of more than 99.99 per cent for very fine particulates. Gases enter the filter device and pass through fabric bags. The bags can be made of different materials (e.g., woven or felted cotton, synthetic or glass-fibre material) depending on the properties of the flue-gas.

To improve the ability to filter dust and enhance the life the filter material is often coated. The most common material is chemically inert limestone (calcium carbonate). It increases the efficiency of dust collection via formation of a so-called filter cake. A filter cake improves the trapping of fine particulates and provides protection of the filter material itself from moisture or abrasive particles. Without a pre-coat the filter material allows fine particulates to bleed through the bag filter system, especially during start-up, as the bag can only do part of the filtration leaving the finer parts to the filter enhancer filter cake.

Gaseous mercury will mainly pass through a bag filter. To make the process more efficient, therefore, gaseous mercury should be converted as far as possible into its oxidized form, which can bind to particles. The efficiency of the bag filter can be increased with different measures, e.g., coupling with dry or semi-dry sorbent injection (spray drying), and providing additional filtration and a reactive surface on the filter cake.

##### *Electrostatic precipitators*

Electrostatic precipitators (ESPs) use electrostatic forces to separate dust particles from exhaust gases. The dust-laden gases flow through the passage formed by the discharge and collecting electrodes. The airborne particles receive a negative charge as they pass through the ionized field between the electrodes. These charged particles are attracted to a grounded or positively charged electrode and adhere to it. The material collected on the electrodes is removed by rapping or vibrating the collecting electrodes, either continuously or at predetermined intervals. Precipitators can usually be cleaned without interrupting the airflow.

The main factors affecting the collection efficiency of electrostatic precipitators are electrical resistivity and particle size distribution. Other influencing factors are temperature, flow-rate of the flue-gas, moisture content, conditioning agents in the gas stream or an increased collection surface.

A wet ESP operates with water vapour-saturated air streams (100 per cent relative humidity). Wet ESPs are commonly used to remove liquid droplets such as sulfuric acid mist from industrial process gas streams. A wet ESP is also commonly used where the gases are high in moisture content, contain combustible particulate, or have particles that are sticky in nature.

##### *Wet scrubbers*

There are two different types of wet scrubbers used, one primarily for de-dusting and the other for the removal of acidic gaseous compounds.

In wet de-dusting scrubbers, the scrubbing liquid (usually water) comes into contact with a gas stream containing dust particles. Vigorous contact of the gas and liquid streams yields high dust removal efficiency. Humidification leads to the agglomeration of fine particles, facilitating their collection. Examples of such scrubbers are Venturi scrubbers, Theissen scrubbers or Radial Flow scrubbers. The dust removal efficiency of these units can be higher than 98 per cent, but the final concentration of dust is relatively high (over 5 mg/Nm<sup>3</sup>).

Wet scrubbers dedicated mainly to the removal of acidic gaseous compounds (often of the spray tower type) remove such pollutants as SO<sub>2</sub>, HCl and HF. A liquor is used to absorb the compounds. They often clean the gas which has been already de-dusted.

The “cleaned” gases from both types of scrubbers normally pass through a mist eliminator to remove water droplets from the gas stream. The water from the scrubber system is either cleaned and discharged, or recycled to the scrubber.

Elemental mercury absorption can be improved by the addition of sulfur compounds or activated carbon to the scrubber liquor (Miller et al., 2014).

Precipitation is another measure often used to remove oxidized mercury in scrubbing waters. Sulfur compounds can serve as a flocculation agent, added to the scrubbing water to convert soluble mercury efficiently into an insoluble compound. In order to bind the mercury directly after its conversion in the liquid phase, another possibility is to add activated carbon to the scrubbing water (Bittig, 2014).

Re-emission of mercury can occur when reducing compounds such as sulfite are present in the scrubbing water. In this case, mercury can be converted back to elemental mercury and re-emitted (Keiser, et al., 2014). This can be avoided by ensuring the presence of ions with which mercury can react to form compounds, such as fluoride, chloride, bromide or iodide.

#### *Summary of dust cleaning devices*

Table 1 provides information on the performances of dust-cleaning devices

**Table 1**

Performance of dust-cleaning devices expressed as hourly average dust concentrations

	Dust concentrations after cleaning (mg/m <sup>3</sup> )
Fabric filters	< 1 – 5
Fabric filters, membrane type	< 1
Dry electrostatic precipitators	< 5 – 15
Wet electrostatic precipitators	< 1 – 5
High-efficiency dust scrubbers	< 20

Source: extracted from the Guidance document on best available techniques for controlling emissions of heavy metals and their compounds from the source categories listed in Annex II to the Protocol on Heavy Metals (ECE/EB.AIR/116, 2013)<sup>10</sup>

#### *Sorbents and oxidizing agents*

Activated carbon is an effective sorbent for mercury capture from flue gas. The activated carbon can be injected into the flue gas upstream of dust-cleaning devices, bag filters or ESPs, or the flue gas can be distributed throughout a carbon filter bed. The effectiveness of activated carbon for mercury control is temperature-dependent. Specifically, the mercury capture or removal capacity of a particular sorbent typically increases as the flue gas temperature decreases. The flue gas temperature is primarily determined by plant design and operating factors. Depending on plant specifics, such as flue gas constituents and operation of the dust control device, mercury removal is relatively effective at temperatures below 175 °C with standard activated carbon. Special high temperature activated carbon sorbents exist for capture of mercury above 175 °C and generally up to 350 °C.

All activated carbons are combustible and, under certain conditions, auto-ignitable, and explosive. The fire and explosion risk is dependent on the combustion and explosion characteristics of the pulverized product, and also on the process and plant conditions. Quality activated carbon is highly processed and poses a lower risk of fire and explosion than low quality carbon. Partially activated carbons can pose a high risk, however, and may require special handling. The adsorbent should be selected carefully and used with proper handling guidance, including fire and explosion-preventing equipment, (e.g., avoidance of low-velocity air flows through beds, avoidance of large-volume deposits in the process by continuous and monitored discharge from the hoppers to avoid fire risks, and good housekeeping for spill cleanup). Dilution of carbon with inert material can suppress the potential for explosion. In applications where

<sup>10</sup> Note there is an issue with oxygen levels used as a proxy for the amount of dilution occurring, and further investigation should be done.

activated carbon is added to gas streams which have little process dust it may be advantageous to blend carbon with non-combustible sorbents (Licata et al., 2007; Derenne et al., 2008)

Mercury capture can be enhanced by adding oxidizing agents (i.e., halogens) to the flue gas or by using activated carbon impregnated with halogens or sulfur. These techniques are described in more detail in the sector chapters. There is a potential risk that dioxins and furans could appear as a result, particularly in the by-products, e.g., in the ashes and sludges. This should be taken into account.

Activated carbon waste should be handled in accordance with Article 11 (Mercury wastes) and in accordance with any applicable national regulations.

Table 2 shows the minimum expected performances of activated carbon techniques for mercury removal.

**Table 2**

Minimum expected performances of activated carbon techniques for mercury removal expressed as hourly average mercury concentrations

	Mercury content after cleaning (mg/m <sup>3</sup> )
Carbon filter	< 0.01
Sulfur-impregnated carbon filter	< 0.01
Carbon injection + dust separator	< 0.05
Injection of brominated activated Carbon+ dust separator	0.001

*Source: extracted from the Guidance document on best available techniques for controlling emissions of heavy metals and their compounds from the source categories listed in annex II to the Protocol on Heavy Metals (ECE/EB.AIR/116, 2013)*

The degree of mercury control in table 2 is largely dependent on the chemical state and form of the mercury (e.g., whether oxidized or particle-bound), and on the initial concentration. The application of these measures depends on the specific processes and is most relevant when concentrations of mercury in the flue gas are high. Examples of performance levels of single techniques or combinations of techniques are given in the sector documents.

## **Annex III**

### **Monitoring**

#### **Mercury emissions monitoring**

## **1 Introduction**

Emissions monitoring is a key component in enabling a party to evaluate the performance of the measures that it has applied. This chapter therefore describes general emissions monitoring techniques that a party may consider. In addition, emissions monitoring techniques specific to the point source categories listed in Annex D are addressed in the relevant chapters of this guidance. Article 8 does not include specific obligations on emissions monitoring. In its paragraph 6, however, the Article does require that the measures applied by a party achieve reasonable progress in reducing emissions over time. In addition, paragraph 11 requires that each party report (pursuant to Article 21) on the effectiveness of the measures that it has taken in controlling and, where feasible, reducing emissions of mercury and mercury compounds from the point sources falling within the source categories listed in Annex D.

## 2 Overview

Monitoring of mercury emissions is an essential part of overall BAT and BEP implementation for controlling mercury emissions to the environment and for maintaining high operating efficiency of the abatement techniques used.

Monitoring of mercury emissions should be conducted according to overall best practices using approved or accepted methods. Representative, reliable and timely data obtained from mercury emissions monitoring are needed to evaluate and ensure the effectiveness of the mercury emission control techniques in use at a facility.

All relevant sources of mercury emissions should undertake mercury emission monitoring. While the techniques are listed in this introduction, each relevant source may have particularly applicable monitoring techniques and practices, which are referenced in the individual chapters of this guidance.

### 2.1 General steps in conducting mercury emissions monitoring

The first step in conducting mercury emissions monitoring is to establish a performance baseline, either by taking direct measurements of the mercury concentrations in the gas streams or using indirect measurements to estimate facility emissions. Subsequently, more measurements are taken at specific time intervals (e.g., daily, weekly, monthly) to characterize the mercury concentration in the gas or the mercury emissions at that point in time. Monitoring is then conducted by compiling and analysing the emissions measurement data to observe trends in emissions and operating performance. Should the measurement data indicate any areas of concern, such as increasing mercury concentrations over time or peaks of mercury emissions associated with certain plant operations, swift action should be taken by the facility to rectify the situation.

### 2.2 Considerations in selecting a measurement or monitoring approach

The selection of a measurement or monitoring approach should begin with consideration of the intended outcomes. Periodic short-term measurements, conducted over a brief time period, such as one hour or one day, may be conducted to provide quick feedback for process optimization. Long-term measurements, such as over several months or a year, using permanently installed equipment on a semi-continuous basis, may be desirable for emission inventory reporting. Continuous emission monitoring which is currently being implemented in some countries may be used to control the process if mercury emissions are highly variable, for example owing to rapidly changing mercury contents in the feed materials.

In addition, site-specific characteristics need to be taken into account when selecting the most appropriate monitoring method and planning for the sampling campaign. Depending on the process, mercury may be present as particle-bound mercury, gaseous elemental mercury ( $\text{Hg}^0$ ) or in the ionized gaseous forms,  $\text{Hg(I)}$  or  $\text{Hg(II)}$  or in combinations of these forms. The partitioning may even vary significantly among facilities conducting similar processes. For some processes, it may be useful to measure these different mercury species individually, for example, to inform decisions on effective control technologies or to conduct risk assessments.

The sampling point should be easily accessible, meet occupational health and safety requirements, meet regulatory requirements, and allow for the retrieval of representative samples. Ideally, the same sampling points should be used for subsequent sampling campaigns to provide comparability between results. To prevent dilution of the samples and avoid false low results, ambient air should not infiltrate the sampling points. Preferably, the gas velocity flow profile should be considered when identifying the sample location to avoid areas of flow disturbance, which would affect the representativeness of the sample. Detailed information on the design and installation of measurement points is available in the European guideline EN 15259:2007<sup>11</sup> “Air Quality-Measurement of stationary source emissions – Requirements for measurement sections and sites and for the measurement objective, plan and report”. The guideline is applicable to continuous as well as discontinuous measurements.

To provide representative data, the sample timing, duration and frequency should be determined by considering various parameters, including the measurement and monitoring method used, measurement location, the facility operating conditions, site-specific process variations, and requirements to show compliance under the applicable regulatory process. Samples should be taken at conditions representative of normal facility operations. If the emissions are highly variable, or emissions are from a batch process, longer sample duration should be used or more samples collected (e.g., samples taken across the entire batch) to provide a reliable average measurement. In addition low concentrations of mercury in the sample stream may necessitate longer duration to provide a total sample mass above the method detection limit. Furthermore, periodic composite samples – for example, over half an hour, 12 hours or 24 hours – provide more representative results compared to random grab samples.

<sup>11</sup> European Committee for Standardization, “EN 15259:2007: Air quality – Measurement of stationary source emissions – Requirements for measurement sections and sites and for the measurement objective, plan and report”, 18 August 2007.  
[http://standards.cen.eu/dyn/www/?p=204:110:0:::FSP\\_PROJECT:22623&cs=106F3444821A456A90F21590F3BFF8582](http://standards.cen.eu/dyn/www/?p=204:110:0:::FSP_PROJECT:22623&cs=106F3444821A456A90F21590F3BFF8582).

Mercury emissions can vary significantly within a single facility over time or among facilities conducting similar processes, because of variable mercury content in the materials entering the process. Mercury concentrations can change rapidly in the fuel, raw materials or other inputs, such as waste. During the emissions measurement procedure, the mercury content in the process inputs should also be documented to assist with quality assurance. When conducting sampling, care must be taken, as far as possible, to ensure that the process is operating at representative conditions, mercury concentrations in the input streams are representative of normal feeds, and that fugitive emissions are minimized. If the operating conditions are not typical, extrapolation of the sampling data may provide results with a large margin of error.

Operating conditions should be documented throughout the sampling campaign. Specific parameters, such as the volumetric gas flow-rate, gas temperature, water vapour content of the gas, static pressure of the gas duct, and atmospheric pressure,<sup>12</sup> should be accurately recorded to allow for conversion of the measured mercury concentrations to standard reference conditions (0 °C, 1 atm, measured or reference oxygen content and on a dry gas basis). The quantity of mercury emitted over time can be determined by multiplying the mercury concentration in the exhaust gas by the stack volumetric gas flow-rate, as follows:

For example:

$$E_{\text{Hg}} = C_{\text{Hg}} \times F \times T$$

Where:

$E_{\text{Hg}}$  = Annual emissions of mercury (kg/y)

$C_{\text{Hg}}$  = Mercury concentration in the gas stream (kg/m<sup>3</sup>)

F = volumetric flow-rate of the gas stream (m<sup>3</sup>/h)

T = operating time per year (h/y)

Most direct emissions monitoring methods rely on sampling at a point source, such as a stack. Measurement of diffuse emissions, including fugitive emissions, is normally not practised and methodologies that do exist for measuring diffuse emissions typically produce results with high uncertainty. Thus, it should be noted that emissions monitoring results from point sources may not provide complete data on the total mercury emissions from a facility.

Monitoring method selection should be based on various criteria, such as site characteristics, process specifics, measurement certainty, cost considerations, regulatory requirements and maintenance requirements. To compare the facility's mercury emissions over time, consistent sampling methods should be used in subsequent years.

## 2.3 Direct measurement methods

Direct measurement methods are generally considered as the most reliable techniques for mercury emissions monitoring. When correctly conducted, these methods can provide representative, reliable data conducive to the more precise measurement of a facility's actual mercury emissions.

### 2.3.1 Short-term measurements

#### 2.3.1.1 Impinger sampling

Impinger sampling of mercury emissions from a stationary source is conducted by manually collecting a sample of exhaust gas from an outlet such as a stack or duct with an isokinetic sampling system, whereby the sample gas stream that is extracted is of the same velocity as the main stream. The isokinetic sampling accounts for changes in gas flow-rate and for some particulate loading in the gas. This method is not suitable, however, for gases with heavy particulate loading.

The method requires the use of an intricate sampling train to recover mercury from the gas stream into a solution that is then sent for laboratory analysis. While this method allows for good accuracy in mercury concentration measurement, it requires continuous attendance during the sampling period. An advantage of this method is that recovery is possible for both mercury in gaseous form and mercury bound to particulate matter. Because of the complexity of this procedure, source testing tends to be performed only periodically (e.g., once or twice per year). In general, facilities engage specialized source testing consultants to conduct the sampling and analysis.

A probe and sample nozzle are inserted into the outlet gas stream to extract a representative sample over a set time period. Since impinger sampling is typically done only a few times per year at most, sampling should be conducted when the process is operating at steady state to allow for extrapolation of the data over an operating year. Operating conditions should be documented before, during and after the sampling campaign. In the United States, the general

<sup>12</sup> EU IPPCB, NFM BREF Draft, February 2013, p. 67.



practice is to take three impinger samples, each several hours in length under typical operating conditions, and to calculate the average of the results for the final concentration value. Careful impinger preparation and post-handling of solutions is critical for the success of impinger methods. Measurement errors are often related to the loss of mercury from the solutions. It is therefore essential to avoid any loss of the sample as this will cause the test results to be misleadingly low.

As this is not a continuous emission monitoring method, the results obtained would not provide data on mercury emissions during irregular events, such as wide production swings, process start-ups, shutdowns or upsets. It should be noted that mercury emissions generated during such events could be significantly higher or lower than during normal operating circumstances.

Even under normal, steady-state conditions, however, there could be significant variability in the mercury volumes being emitted when the mercury content in fuels or feedstocks fluctuates over short periods. In particular, for waste incineration and cement facilities using waste fuels, the mercury content entering the system or facility may be unpredictable. Similarly, in the non-ferrous metals sector, mercury in furnace feeds may change rapidly depending on the concentrates being processed. In such cases, results from intermittent impinger sampling may not provide representative data when extrapolated over a long period of time (e.g., annual averages). Thus, increasing the sampling frequency (e.g., to three measurements per year over many years) can provide a better understanding of actual source emissions over time.

To obtain maximum value for investment, mercury emissions source testing should be conducted during broader sampling campaigns for air pollutants such as particulate matter, NO<sub>x</sub>, SO<sub>2</sub>, and VOC. The addition of mercury testing when conducting these broader air pollutant sampling campaigns may increase the operating costs of a facility. Actual costs will depend on various factors, such as sample method, sampling frequency, support services, analytical methods and site preparation.

#### Existing reference methods:

- *Method EN 13211:2001/AC: 2005 – Air quality – Stationary source emissions – Manual method of determination of the concentration of total mercury*<sup>13</sup>

This is the reference method in Europe for the measurement of total mercury. The method is applicable for the concentration range of total mercury from 0.001 to 0.5 mg/m<sup>3</sup> in exhaust gases. The procedure is a manual method of determining the concentration of total mercury using an acid aqueous solution of potassium permanganate or potassium dichromate for the sampling of vapour-phase mercury, together with a filter paper for the collection of particle-bound mercury. The sampling time should be between 30 minutes and two hours.

#### US EPA Method 29 – Metals Emissions from Stationary Sources<sup>14</sup>

In this method, particulate emissions are isokinetically collected in the probe and on a heated filter, and gaseous emissions are then collected in an aqueous acidic solution of hydrogen peroxide (analysed for all metals including mercury) and an aqueous acidic solution of potassium permanganate (analysed only for mercury). The recovered samples are digested, and appropriate fractions are analysed for mercury by cold vapour atomic absorption spectroscopy (also referred to as CVAAS) and for various other metals using inductively coupled plasma-mass spectroscopy (also referred to as ICP-MS). This method is suitable for measurement of mercury concentrations ranging from approximately 0.2 to 100 µg/m<sup>3</sup>. Since this method collects oxidized mercury in the hydrogen peroxide solution, it is appropriate for the determination of mercury speciation.

#### US EPA SW-846 Method 0060 – Determination of Metals in Stack Emissions<sup>15</sup>

This method is used to determine the concentration of metals in stack emissions from hazardous waste incinerators and similar combustion processes. In this method, a sample is withdrawn from the flue gas stream isokinetically through a probe and filter system. Particulate emissions are collected in the probe and on a heated filter and gaseous emissions are collected in a series of chilled impingers. Two impingers are empty, two impingers contain an aqueous solution of dilute nitric acid combined with dilute hydrogen peroxide, two other impingers contain acidic potassium permanganate solution, and the last impinger contains a desiccant.

<sup>13</sup> European Committee for Standardization, “EN 13211:2001/AC:2005: Air quality – Stationary source emissions – Manual method of determination of the concentration of total mercury”, 15 February 2005. [http://standards.cen.eu/dyn/www/f?p=204:110:0:::FSP\\_PROJECT,FSP\\_ORG\\_ID:25042,6245&cs=19B884B499893080A731C45504F6F2FB2](http://standards.cen.eu/dyn/www/f?p=204:110:0:::FSP_PROJECT,FSP_ORG_ID:25042,6245&cs=19B884B499893080A731C45504F6F2FB2).

<sup>14</sup> US EPA, “Method 29 – Metals Emissions from Stationary Sources”. <http://www.epa.gov/ttn/emc/methods/method29.html>.

<sup>15</sup> US EPA, “Method 0060 – Determination of Metals from Stack Emissions”. <http://www.epa.gov/wastes/hazard/testmethods/sw846/pdfs/0060.pdf>.

The recovered samples are digested, and appropriate fractions are analysed for mercury by CVAAS. Remaining fractions may be analysed for various other metals by inductively coupled plasma-atomic emission spectrometry (ICP-AES), flame atomic absorption spectrometry (FLAA), or ICP-MS.

Method ASTM D6784- 02 (Reapproved 2008) – Standard Test Method for Elemental, Oxidized, Particle-Bound and Total Mercury in Flue Gas Generated from Coal-fired Stationary Sources (Ontario Hydro Method)<sup>16</sup>

In this method a sample is withdrawn from the flue gas stream isokinetically through a probe and filter system, maintained at 120 °C or the flue gas temperature (whichever is greater), followed by a series of impingers in an ice bath. Particle-bound mercury is collected in the front half of the sampling train. Oxidized mercury is collected in impingers containing a chilled aqueous potassium chloride solution.

Elemental mercury is collected in subsequent impingers (one impinger containing chilled aqueous acidic solution of hydrogen peroxide and three impingers containing chilled aqueous solutions of potassium permanganate). Samples are recovered, digested, and then analysed for mercury using CVAAS or cold vapour atomic fluorescence spectroscopy (CVAFS). The scope of the method applies to determination of elemental, oxidized, particle-bound and total mercury emissions from coal-fired stationary sources with concentrations ranging from approximately 0.2 to 100 µg/m<sup>3</sup>.

- *JIS K0222 (Article 4(1) – Methods for determination of mercury in stack gas (wet absorption and cold vapour atomic absorption method)*<sup>17</sup>

This reference method from Japan measures total vapour phase mercury in the sample gas. In this method, vapour phase mercury is collected in an aqueous acidic solution of potassium permanganate (non-limiting isokinetic sampling). The dust containing the particle-bound mercury in the stack gas is isokinetically collected on the filter in accordance with reference method JIS Z8808:2013<sup>18</sup> “Methods of measuring dust concentration in flue gas”. The recovered samples are digested, and appropriate fractions are analysed for mercury by cold vapour atomic absorption spectrometry.

### 2.3.1.2 Sorbent trap sampling

Sorbent traps provide an average mercury concentration measurement over a sampling period, similar to the impinger methods. In addition, sorbent traps provide more stable mercury retention and a simpler sampling protocol, which allows for unattended operation of the sampling over extended periods.

Sorbent traps are used to measure mercury emissions from point sources with low particulate matter concentrations. In general, samples are taken at a location following a particulate control device.

Typically, duplicate samples are extracted in parallel using probes inserted into the gas stream. The probes contain sorbent traps, which accumulate mercury from the gas. The sorbent material used is mainly halogenated carbon. Standard sorbent traps are intended to measure gaseous mercury but, because of the operation of the sampling method, particulates containing mercury can be drawn into the sorbent traps. This particulate is analysed and the measured amount is added to the carbon bed amounts to form the total mercury value. However, the sorbent trap method does not collect particulates isokinetically so it is not an accurate method for measuring particle-bound mercury. Nevertheless, because the facilities concerned would be expected to run efficient particulate matter control devices, there should be minimal amounts of particle-bound mercury in the gas stream.

At the end of the sampling period, the sorbent traps are manually replaced, and the used traps are analysed for mercury content. If results of the sorbent tube analyses agree within a specified range, then the two results are averaged for the final value. Analytical methods for mercury content include traditional wet chemical methods or small thermal desorption systems, which can provide immediate results. A distinct advantage of this method is that operating personnel can be quickly trained to conduct the sampling. Another advantage is that the results from thermal desorption analysis may be known while the tester is still in the field. This is useful for engineering tests with varying conditions, or for mercury monitor relative accuracy test audits.

Sorbent traps provide good sensitivity and accuracy for mercury across a wide range of concentrations. It is necessary, however, to know the expected minimum and maximum concentrations in the flue gas so that the correct sorbent trap and sampling time can be selected. For instance, if the concentration is too large or the sampling time too long, the mercury absorption capacity of the sorbent trap could be exceeded. This event would cause an under-reporting of the

<sup>16</sup> American Society for Testing and Materials (ASTM), “Standard Test Method for Elemental, Oxidized, Particle-Bound and Total Mercury in Flue Gas Generated from Coal-Fired Stationary Sources (Ontario Hydro Method)”, 2008. <http://www.astm.org/Standards/D6784.htm>.

<sup>17</sup> Japanese Standards Association, “JIS K0222;1997; Methods for determination of mercury in stack gas”, 20 August 1997.

<sup>18</sup> Japanese Standards Association, “JIS Z8808:2013: Methods of measuring dust concentration in flue gas”, 20 August 2013.

actual mercury concentration. On the other hand, a short sampling time of flue gas with very low concentrations of mercury can result in too little mercury captured in the traps, which would negatively affect trap analysis accuracy.

Existing reference methods:

- *US EPA Method 30B – Determination of Total Vapor Phase Mercury Emissions from Coal-Fired Combustion Sources Using Carbon Sorbent Traps*<sup>19</sup>

This method is a procedure for measuring total vapour phase mercury emissions from coal-fired combustion sources using sorbent trap sampling and an extractive or thermal analytical technique. This method is intended for use only under relatively low particulate conditions (e.g., sampling after all pollution control devices). Method 30B is a reference method for relative accuracy test audits (RATAs) of vapour phase mercury CEMS and sorbent trap monitoring systems installed at coal-fired boilers and is also appropriate for mercury emissions testing at such boilers. In cases where significant amounts of particle-bound mercury may be present, an isokinetic sampling method for mercury should be used.

- *JIS K0222 (Article 4(2) – Methods for determination of mercury in stack gas (Gold amalgamation and cold vapour atomic absorption method)*<sup>20</sup>

This reference method from Japan uses a sorbent containing gold and measures vapour phase elemental mercury ( $\text{Hg}^0$ ) concentration in stack gas. After the sample gas is washed by water and vapour phase oxidized mercury ( $\text{Hg}^{2+}$ ) in the sample gas is removed, vapour phase mercury in the sample gas is trapped by the sorbent as gold amalgam. The sorbent is heated and vaporized mercury is measured by cold vapour atomic absorption spectrometry.

### 2.3.1.3 Instrumental testing

Instrumental testing can be used for short-term measurements of vapour phase mercury concentrations in gas. In this method, a gas sample is continuously extracted and conveyed to a mobile analyser which measures elemental and oxidized mercury ( $\text{Hg}^0$  and  $\text{Hg}^{2+}$ ), either separately or simultaneously. The mobile analyser uses a measurement technique similar to that used in continuous emissions monitoring (see section 2.4 below).

- *US EPA Method 30A – Determination of Total Vapour Phase Mercury Emissions from Stationary Sources (Instrumental Analyser Procedure)*<sup>21</sup>

Method 30A is a procedure for measuring total vapour phase mercury emissions from stationary sources using an instrumental analyser. This method is particularly appropriate for performing emissions testing and for conducting RATAs of mercury continuous emissions monitoring systems and sorbent trap monitoring systems at coal-fired combustion sources. Quality assurance and quality control requirements are included.

## 2.3.2 Long-term measurements

### 2.3.2.1 Sorbent trap monitoring systems

Sorbent trap monitoring systems are used to monitor mercury emissions from point sources with low particulate matter concentrations. These systems are permanently installed at a suitable sampling point, using sorbent traps to provide consistent, representative samples. In contrast to the use of sorbent traps for short-term measurements over brief periods, sorbent trap monitoring systems are operated on a continuous basis over set time periods, which may range between 24 and 168 hours,<sup>22</sup> or even 14 days for samples of low mercury concentration. As with other extractive methods, the location of the sample point should be carefully chosen to provide representative and useful data.

The cost of installing a sorbent trap monitoring system is estimated at about \$150,000. Using United States data from 2010, annual operating costs for the sorbent trap monitoring system for coal-fired power plants range between \$26,000 and \$36,000 and annual labour costs for operation between \$21,000 and \$36,000.<sup>23</sup>

Existing reference methods:

<sup>19</sup> US EPA Method 30B, <http://www.epa.gov/ttn/emc/promgate/Meth30B.pdf>.

<sup>20</sup> Japanese Standards Association, “*JIS K0222:1997; Methods for determination of mercury in stack gas*”, 20 August 1997.

<sup>21</sup> US EPA Method 30A, <http://www.epa.gov/ttnemc01/promgate/Meth30A.pdf>.

<sup>22</sup> US EPA Performance Specification 12B, p.13. <http://www.epa.gov/ttn/emc/perfspec.html>.

<sup>23</sup> Amar, P., C. Senior, R. Afonso and J. Staudt (2010). NESCAUM Report “*Technologies for Control and Measurement of Mercury Emissions from Coal-Fired Power Plants in the United States: A 2010 Status Report*”, July 2010, pp. 2–22. <http://www.nescaum.org/activities/major-reports>.

- US EPA PS-12b (*Performance Specification 12b*) – *Specifications and Test Procedures for Monitoring Total Vapour Phase Mercury Emissions from Stationary Sources Using a Sorbent Trap Monitoring System*<sup>24</sup>

This performance specification is used to establish performance benchmarks for, and to evaluate the acceptability of, sorbent trap monitoring systems used to monitor total vapour-phase mercury emissions in stationary source flue gas streams. This method is appropriate for long-term mercury measurements up to a sampling time of 14 days in order to monitor low levels of mercury emissions.

## 2.4 Continuous measurements

### 2.4.1 Continuous emission monitoring systems (CEMS)

Continuous emission monitoring systems (CEMS) are used to monitor gaseous emissions from point sources over long durations. This monitoring method does not measure particulate mercury. With this automated method, representative samples are taken continuously or at set time intervals using a probe inserted into the gas stream. CEMS are therefore useful for uninterrupted monitoring of mercury emissions, which can be variable over short time intervals because of changing mercury concentrations in raw materials, fuels or reagents. For example, CEMS would be useful during the co-incineration of waste material as fuel because of the rapidly changing mercury content in the waste. Regulatory monitoring and reporting requirements have led to the growing use of this method in the United States and the European Union among certain sources over the last 10 years. While the cost of installation and operation may be high compared to other methods, CEMS provide the greatest data quantity, generating real-time information over various types of operations and process fluctuations.

The location of the sample point should be carefully chosen to provide representative and useful data. In a complex facility with multiple outlets potentially emitting mercury, the cost of installing CEMS on each outlet may be very high. Using United States data from 2010, the general cost of installing a new mercury CEMS in a coal-fired power plant is estimated at about \$500,000, of which \$200,000 is for the system, including start-up, training and calibration systems, and between \$200,000 and \$300,000 for site preparation<sup>25</sup> in newer systems, where daily calibrations are not required costs are much lower. Recent information from a provider of mercury measurement equipment in the European Union indicates a cost of approximately €150,000 (\$170,000), which includes the system itself, necessary infrastructure and installation, servicing, calibration and validation.<sup>26</sup>

At facilities with multiple stacks and where CEMS would be technically and economically viable, and also informative, the CEMS should be located on the outlet emitting the bulk or largest mass of mercury emissions at the facility. While in such cases the CEMS would not provide information from all gas outlets, the resulting data may provide a useful real-time indication of process performance trends and mercury control efficiency.

For mercury CEMS, the extracted sample is filtered to remove particulate matter and the resulting vaporous sample is routed to a mercury analyser. In general, CEMS analysers should be kept under steady temperature control to avoid instrument errors and drift in the results. It should be noted that these analysers detect mercury only in the vapour phase ( $\text{Hg}^0$  and  $\text{Hg}^{2+}$ ), and any particle-bound mercury in the sample would be trapped by the filter. As, however, the facilities concerned should be operating with efficient particulate matter control devices, there should not be significant concentrations of particulate matter in the final stack emissions and, consequently, little particle-bound mercury in the final gas stream. CEMS can be used for sampling of dry flue gas or water saturated flue gas, such as after a wet scrubber. CEMS used to monitor water-saturated gas require a special fixed filter probe, however, to avoid blockage from condensation of water. It should be noted that some CEMS could also experience interference from other substances in the gas stream.

Mercury CEMS directly measure elemental mercury ( $\text{Hg}^0$ ) gas using either cold vapour atomic adsorption (CVAA) or cold vapour atomic fluorescence (CVAFA). Accordingly, gaseous oxidized mercury ( $\text{Hg}^{2+}$ ) in the sample gas must be reduced to  $\text{Hg}^0$  before it can be measured. This process is referred to as sample gas conversion. The reduction occurs when passing the sample gas either through a high temperature, thermal reduction cell or through an impinger containing a reducing chemical, such as tin chloride.

CEMS can be used to provide mercury emissions data continuously, or over set time periods, such as half-hourly, or hourly. Notably, data from the CEMS can be relayed on a continuous basis to the process control system through a feedback loop to indicate real-time operating trends for process control and assist in maintaining peak operating efficiency.

<sup>24</sup> US EPA Performance Specification 12B. <http://www.epa.gov/ttn/emc/perfspec.html>.

<sup>25</sup> Amar, P., C. Senior, R. Afonso and J. Staudt (2010). NESCAUM Report “*Technologies for Control and Measurement of Mercury Emissions from Coal-Fired Power Plants in the United States: A 2010 Status Report.*”, July 2010, pp. 2–7. <http://www.nescaum.org/activities/major-reports>.

<sup>26</sup> Gerter, F., and A.G. Sick, Germany, personal communication. September 2015.

The CEMS must be correctly calibrated to ensure data accuracy. This is achieved by comparing readings with samples taken simultaneously from the same sampling point that are then analysed by relevant manual source-testing methods. Some calibration gas standards may be available and, if so, may be used to calibrate the instrument directly. Regular maintenance and quality control procedures should be conducted, as per the relevant authority or manufacturer specifications, to minimize data drift.

Existing reference methods:

- *US EPA PS-12a (Performance Specification 12a) – Specifications and Test Procedures for Total Vapour Phase Mercury Continuous Emission Monitoring Systems in Stationary Sources*<sup>27</sup>

This performance specification is used for evaluating the acceptability of total vapour phase mercury CEMS installed at stationary sources at the time of, or soon after, installation and whenever specified as per regulatory requirements. The CEMS measures total mercury concentration in  $\mu\text{g}/\text{m}^3$  of vapour phase mercury, regardless of speciation, and records the results at standard conditions on a wet or dry basis. This method does not measure mercury bound to particulate matter.

- *EN 14884:2005 – Air quality – Stationary source emissions – Determination of total mercury: Automated measuring systems*<sup>28</sup>

This European standard describes the quality assurance procedures related to CEMS for the determination of total mercury in flue gas, in order to meet the uncertainty requirements on measured values specified by regulations, national legislation or other requirements. The standard is in line with the general standard on quality assurance on CEMS (EN 14181:2014 – Stationary source emissions – Quality assurance of automated measuring systems<sup>29</sup>).

Standard EN 14181:2014 is designed to be used after the CEMS has passed a suitability test (QAL1, as defined in EN 15267<sup>30</sup>) demonstrating that it is suitable for the intended purpose before installation on site. EN14181:2014 describes the quality assurance procedures needed to ensure that a CEMS is capable of meeting the uncertainty requirements on measured values, which are specified in European Union or national legislation.

- *Method EN 13211:2001/AC: 2005 – Air quality – Stationary source emissions – Manual method of determination of the concentration of total mercury*<sup>31</sup>

This European standard specifies a manual reference method for the determination of the mass concentration of mercury in exhaust gases from ducts and stacks. This is the reference method for comparative measurements for calibrating mercury CEMS. This method has been previously listed in section 1.1.2.1.1 on impinger sampling.

- *JIS K0222 (Article 4(3) – Methods for determination of mercury in stack gas (Continuous monitoring method)*<sup>32</sup>

This reference method from Japan directly measures total vapour phase mercury from stationary sources on a continuous basis using cold vapour atomic absorption spectrometry. In this method, vapour phase oxidized mercury ( $\text{Hg}^{2+}$ ) in the sample gas is reduced to elemental mercury ( $\text{Hg}^0$ ) by passing the sample gas through tin chloride.

<sup>27</sup> US EPA Performance Specification 12A. <http://www.epa.gov/ttn/emc/perfspec.html>.

<sup>28</sup> European Committee for Standardization, “EN 14884:2005: Air quality – Stationary source emissions – Determination of total mercury: automated measuring systems”, 28 November 2005. [http://standards.cen.eu/dyn/www/f?p=204:110:0:::FSP\\_PROJECT:22225&cs=1D527AD08718E6354287EA554A53ADF26](http://standards.cen.eu/dyn/www/f?p=204:110:0:::FSP_PROJECT:22225&cs=1D527AD08718E6354287EA554A53ADF26).

<sup>29</sup> European Committee for Standardization, “EN 14181:2014: Stationary source emissions - Quality assurance of automated measuring systems”, 11 October 2014. [http://standards.cen.eu/dyn/www/f?p=204:110:0:::FSP\\_PROJECT:33416&cs=1D563C09742AECB59945D4E1D645A5DCB](http://standards.cen.eu/dyn/www/f?p=204:110:0:::FSP_PROJECT:33416&cs=1D563C09742AECB59945D4E1D645A5DCB).

<sup>30</sup> EN 15267-1 Air quality – Certification of automated measuring systems – Part 1: General principles, EN 15267-2: Air quality – Certification of automate measuring systems – Part 2: Initial assessment of the AMS manufacturer’s quality management system and post certification surveillance for the manufacturing process, EN 15267-3: Air quality – Certification of automated measuring systems – Part 3: Performance criteria and test procedures for automated measuring systems for monitoring emissions from stationary sources.

<sup>31</sup> European Committee for Standardization, “EN 13211:2001/AC:2005: Air quality - Stationary source emissions - Manual method of determination of the concentration of total mercury”, February 15, 2005. [http://standards.cen.eu/dyn/www/f?p=204:110:0:::FSP\\_PROJECT,FSP\\_ORG\\_ID:25042,6245&cs=19B884B499893080A731C45504F6F2FB2](http://standards.cen.eu/dyn/www/f?p=204:110:0:::FSP_PROJECT,FSP_ORG_ID:25042,6245&cs=19B884B499893080A731C45504F6F2FB2).

<sup>32</sup> Japanese Standards Association, “JIS K0222;1997; Methods for determination of mercury in stack gas”, 20 August 1997.

## 2.5 Indirect measurement methods

The indirect measurement methods described below are helpful in estimating mercury emissions from a process or facility. In general, most indirect measurement methods are not usually considered to be as reliable and accurate as direct measurement techniques for mercury emissions monitoring. In contrast to direct measurement methods, indirect measurement methods provide no information on mercury concentrations in stack gases or total emission rates. When conducted according to proper test procedures, the direct measurement methods previously listed would provide more representative mercury emissions data than most indirect measurement methods. Nevertheless, these non-measurement engineering methods are useful as investigative and screening tools for the monitoring of general process performance and estimation of mercury abatement efficiency. For reporting purposes, these indirect measurement methods may be used to provide a general estimate of facility-level emissions if direct measurement methods are not available or applicable.

### 2.5.1 Mass balance

Mass balance is conducted by applying the law of mass conservation to a system (e.g., facility, process or piece of equipment). In such a system, any mercury entering the process in the feedstock, additives, or fuel must exit via the products, by-products, waste or emissions and releases. Mercury emissions and releases are therefore determined from the differences in input, output, accumulation and depletion. The general equation for a mass balance is:<sup>33</sup>

$$M_{\text{in}} = M_{\text{out}} + M_{\text{accumulated/depleted}}$$

Where:

$M_{\text{in}}$  = mass of mercury entering the facility in the feedstock, fuel, additives, etc.

$M_{\text{out}}$  = mass of mercury leaving the facility in finished products, byproducts, wastes and emissions and releases

$$(M_{\text{out}} = M_{\text{product}} + M_{\text{by-product}} + M_{\text{waste}} + M_{\text{emissions}} + M_{\text{releases}})$$

$M_{\text{accumulated/depleted}}$  = mass of mercury accumulated or depleted within the facility

To calculate mercury emissions in a system using a mass balance, the mercury concentrations and mass flow-rates of all other streams (e.g., products, by-products, effluents, sludges) should be tracked and recorded over a specified period. Mercury mass data would be calculated by multiplying the mercury concentration by the stream mass flow-rate and the time period (e.g., one year). An advantage of using the mass balance method is that mercury emissions can be estimated for both point and diffuse sources (including fugitive emissions), if a party wishes to estimate emissions from non-point sources as well.

In a system with multiple emission sources and limited data from outlet stacks or ducts, the mass balance approach may provide useful and representative information on mercury flows over a long period, such as a year. In processes where the emissions could vary greatly over time, results from a complete annual mass balance may provide more representative emissions data than punctual direct measurements, such as an annual stack test. For example, cement facilities in the European Union have come up against uncertain readings using direct measurement methods due to high uncertainty in emissions volume measurement at the stack. For these facilities, use of the mass balance method has reduced the relative uncertainty in the estimation of mercury emissions, by comparison with direct measurement methods.

Accurate, representative measurements of mercury content in variable fuels or feed materials may, however, be difficult to achieve. In addition, in cases where internal mercury loads are recycled in the process (e.g., in stockpiles, intermediate products, sludges), care should be taken to account for mercury in these streams. In complex processes with multiple input and output flows, or where data are estimated, it may be difficult to come up with definitive figures for the mass balance.

### 2.5.2 Predictive emissions monitoring systems (PEMS)

Predictive emissions monitoring systems (PEMS), also referred to as parametric monitoring, operate by developing correlations between process operating parameters and mercury emissions rates using the continuous monitoring of surrogate parameters, emission factors and source testing. This method can be useful in providing an indication of mercury control efficiency on a real-time basis. No ongoing mercury sampling is actually conducted in this method. In modern facilities, parameters such as fuel usage, furnace temperature, gas pressure and flow-rate are typically monitored on a continuous basis using process control systems to ensure operational efficiency. While these types of

<sup>33</sup> Environment Canada, "Guide for Reporting to the National Pollutant Release Inventory (NPRI) 2012 and 2013, Canadian Environmental Protection Act, 1999 (CEPA 1999)", 2013, p. 18. <https://www.ec.gc.ca/inrp-npri/default.asp?lang=En&n=28C24172-1>.

indicators may be a useful starting point, the selection of relevant parameters and their corresponding correlations to mercury emission rates would likely be unique to the process or facility.

In certain types of processes where there is little variability in the mercury content of the feedstock, fuel and other input streams, PEMS may offer a useful means of providing an indication of mercury emission trends. For example, some facilities in the industrial gold sector in the United States monitor the operating efficiency of their mercury chloride scrubbers, tracking the scrubber inlet solution pressure, inlet gas temperature and mercury(II) chloride concentration in the solution exiting the scrubber.

PEMS may not, however, be a reliable method of mercury emissions monitoring in applications where mercury content in fuels or feedstocks can vary significantly over short periods. For example, in waste incineration and cement facilities using waste fuels, the mercury content entering the system or facility is generally unpredictable. In coal-fired power plants, mercury emissions can vary in response to changes in the mercury content of the coal. Similarly, in the non-ferrous metals sector, mercury in furnace feeds can change rapidly depending on the concentrates being processed. In addition, mercury emissions can vary in many processes because of temperature fluctuations and changes in mercury speciation. As a result, the establishment of correlations between surrogate parameters and mercury emissions may not produce representative results. If PEMS are considered, thorough analysis should first be carried out to determine the uncertainty of the method on a case-by-case basis and they should be regularly compared to a reference test method. When a sufficient, comprehensive pool of reference data can be collected to provide a substantial base to develop the PEMS algorithm, the data quality provided by the PEMS would be expected to improve.

### 2.5.3 Emission factors

While the use of emission factors is not a monitoring method per se, this engineering technique can be used to provide a useful general estimate of mercury emissions from a system or facility.

Emission factors are used to provide an estimate of the quantity of emissions released from a source based on typical levels of emissions from that activity. For mercury, emission factors could be expressed as the mass of mercury emitted divided by: the mass or volume of input material consumed; or the mass or volume of output material generated.

Site-specific emission factors, developed by facilities on the basis of actual emissions testing data and source activity information, are expected to provide more accurate estimates than general, published emission factors. Site-specific emission factors would need to be established by testing during periods of normal operation, with a view to providing a better representation of the average mercury emissions rate from the particular process or facility. If site-specific measurement data become available, calculations based on those measured values would be preferred to the use of general published factors.

Where site-specific emission factors are unavailable, published emission factors may be used to provide a rough emissions estimate. Published emission factors may be available for the overall process or for the particular mercury control device. It should be noted, however, that such general emission factors provide highly uncertain emission estimates.

That said, in processes where there may be variability in the mercury content of fuels or feedstocks, emission factors may not provide reliable estimates of mercury emissions. For example, in waste incineration or cement manufacturing using waste fuels, mercury content in the fuel can vary significantly within short periods.

The general equation for estimating mercury emissions using an emissions factor is:

$$E_{\text{Hg}} = \text{BQ} \times \text{CEF}_{\text{Hg}} \text{ or}$$

$$E_{\text{Hg}} = \text{BQ} \times \text{EF}_{\text{Hg}} \times (100 - \text{CE}_{\text{Hg}})/100$$

Where:

$E_{\text{Hg}}$  = Emission of mercury (kg or other unit of mass)

$\text{BQ}$  = Activity rate or base quantity (base quantity unit)

$\text{CEF}_{\text{Hg}}$  = Controlled emission factors of mercury (kg/BQ) [dependent on any emission control devices installed]

$\text{EF}_{\text{Hg}}$  = Uncontrolled emission factors of mercury (kg/BQ)

$\text{CE}_{\text{Hg}}$  = Overall emission control efficiency of mercury (per cent)

### 2.5.4 Engineering estimates

General estimates of mercury emissions can also be obtained using engineering principles, knowledge of the relevant chemical and physical processes, application of related chemical and physical laws, and familiarity with site-specific characteristics.

For example, annual mercury emissions from fuel use can be estimated as follows:

$$E_{\text{Hg}} = Q_{\text{F}} \times \% \text{ Hg} \times T$$

Where:

$E_{\text{Hg}}$  = Annual emissions of mercury (kg/y)

$Q_{\text{F}}$  = Rate of fuel use (kg/h)

% Hg = per cent of mercury in fuel, by weight

T = operating time (h/y)

Engineering estimates should only be considered as rapid general approximations with a high level of uncertainty. In order to improve accuracy, results from engineering estimates should be compared periodically with data obtained from direct measurement methods. Where site-specific information becomes available, those data are expected to provide more useful information and would be preferred in terms of understanding actual source emission rates. Engineering estimates are the last resort where no emissions data or emission factors are available.

### **2.5.5 Emissions reporting**

Emissions reporting is an essential part of the emissions monitoring cycle at the facility level.

Where compliance with a legal or regulatory measure must be demonstrated, the operator is generally responsible for reporting monitoring results to the competent authority. In addition, facility-level data constitute an essential component of national emissions inventories that are compiled using a bottom-up approach. Even where emissions reporting is not explicitly required, it is considered a best practice to share data voluntarily with authorities and the public concerned.

Reporting of emissions monitoring involves summarizing and presenting the monitoring results and related information, such as quality assurance and quality control methods, in an effective way, according to the needs of the intended audience. The report should be clear, transparent and accurate. Results should be presented in a useful, informative format.

Mercury emissions should be expressed in one or more of the following ways: mercury concentration in the outlet gas; mass of mercury emitted per amount of product produced (emission factor); and mass of mercury emissions over a given time period (e.g., per day or per year).

Quality considerations regarding sampling, analysis and the results should be discussed in the report. In addition, the measurement results should be provided in a format that would enable the correlation of mercury emissions with process operating parameters.

Clarity should be provided on the method used (e.g., standards used for sampling and analysis) and conditions encountered during data collection, such as: process conditions; production rate during sampling; occurrences or malfunctions during sampling in the production process or the abatement systems; and variations in the input material.



## **Annex IV**

### **Coal-fired power plants and coal-fired industrial boilers**

#### **Guidance on Best Available Techniques and Best Environmental Practices to Control Mercury Emissions from Coal-fired Power Plants and Coal-fired Industrial Boilers**

##### **Summary**

Coal-fired power plants and coal-fired industrial boilers constitute a large and important source of atmospheric mercury emissions. In 2010, coal burning was responsible for the emission of some 475 tons of mercury worldwide, the majority of which was from power generation and industrial boiler use (UNEP, 2013a). This represents about 40 per cent of the total global anthropogenic emissions. Coals used for combustion throughout the world contain trace amounts of mercury that, when uncontrolled, are emitted into the atmosphere.

This chapter provides guidance on best available techniques (BAT) and best environmental practices (BEP) for controlling and, where feasible, reducing mercury emissions from coal-fired power plants and coal-fired industrial boilers, which are covered by Annex D of the Convention.

Most coal-fired power plants are large electricity-producing plants; some also supply heat. Industrial boilers provide heat or process steam to meet the needs of the facility where they are installed.

Mercury emissions from coal-fired combustion plants are affected by a number of variables, including mercury concentration and speciation in coal; coal type and composition; type of combustion technology; and control efficiency of existing pollution control systems. Mercury emission control technologies are generally similar for all coal-fired boilers, however, regardless of their application at power plants or industrial facilities.

Air pollution control systems are already widely used in a number of countries to reduce emissions of traditional air pollutants other than mercury, such as particulate matter, oxides of nitrogen, and sulfur dioxide. Even when not primarily designed for mercury capture, these systems provide the co-benefit of reducing mercury emissions, as they are able to capture some of the mercury in the flue gases. Dedicated mercury control techniques have been developed and are being applied in a number of countries to provide additional mercury control in cases where co-benefit techniques are not able to provide sufficient and reliable mercury reductions.

This chapter discusses a variety of BAT used for mercury control and provides indicative information on their emission performance and estimated costs. It also describes important components of BEP for the operation of coal-fired facilities. Finally, it presents selected emerging mercury emission control techniques and discusses mercury emission monitoring in the specific context of coal-fired plants.

## Table of Contents

<b>1</b>	<b>Introduction</b> .....	<b>30</b>
<b>2</b>	<b>Processes used in coal-fired power plants and coal-fired industrial boilers, including consideration of input materials and behaviour of mercury in the process</b> .....	<b>31</b>
<b>2.1</b>	<b>Coal properties</b> .....	<b>31</b>
<b>2.2</b>	<b>Mercury transformations during combustion of coal</b> .....	<b>33</b>
<b>3</b>	<b>Menu of mercury emission reduction techniques</b> .....	<b>35</b>
<b>3.1</b>	<b>Coal washing</b> .....	<b>35</b>
<b>3.2</b>	<b>Contribution of APCs in terms of mercury removal</b> .....	<b>35</b>
3.2.1	Particulate matter control devices .....	38
3.2.2	SO <sub>2</sub> control devices .....	40
3.2.3	Selective catalytic reduction for NO <sub>x</sub> control .....	41
<b>3.3</b>	<b>Co-benefit enhancement techniques</b> .....	<b>42</b>
3.3.1	Coal blending .....	42
3.3.2	Mercury oxidation additives.....	43
3.3.3	Wet scrubber additives for mercury reemission control.....	44
3.3.4	Selective mercury oxidation catalyst.....	45
<b>3.4</b>	<b>Activated carbon injection for dedicated mercury control</b> .....	<b>45</b>
3.4.1	Injection of sorbent without chemical treatment .....	46
3.4.2	Injection of chemically treated sorbent .....	47
3.4.3	Activated carbon injection applicability restrictions .....	48
<b>3.5</b>	<b>Cost of mercury control technologies</b> .....	<b>48</b>
3.5.1	Costs for co-benefit mercury control technologies.....	49
3.5.2	Costs for co-benefit enhancement techniques and ACI.....	50
<b>4</b>	<b>Emerging techniques</b> .....	<b>52</b>
<b>4.1</b>	<b>Non-carbon sorbents</b> .....	<b>52</b>
<b>4.2</b>	<b>Non-thermal plasma</b> .....	<b>52</b>
<b>4.3</b>	<b>Cerium-treated activated coke</b> .....	<b>52</b>
<b>4.4</b>	<b>Sorbent polymer composite module</b> .....	<b>52</b>
<b>5</b>	<b>BAT and BEP for coal combustion</b> .....	<b>53</b>
<b>5.1</b>	<b>Best available techniques</b> .....	<b>53</b>
5.1.1	Primary measures to reduce the mercury content of coal.....	53
5.1.2	Measures to reduce mercury emissions during combustion .....	53
5.1.3	Mercury removal by co-benefit of conventional APCs.....	53
5.1.4	Dedicated mercury control technologies .....	53
<b>5.2</b>	<b>Best environmental practices</b> .....	<b>53</b>
5.2.1	Key process parameters.....	53
5.2.2	Consideration of energy efficiency for whole plant .....	53
5.2.3	APCS maintenance and removal efficiency .....	54
5.2.4	Environmentally sound management of the plant .....	54
5.2.5	Environmentally sound management of coal combustion residues .....	54
<b>6</b>	<b>Mercury emissions monitoring</b> .....	<b>56</b>
<b>6.1</b>	<b>Continuous emissions monitoring</b> .....	<b>56</b>

---

6.2	Sorbent trap monitoring .....	56
6.3	Impinger sampling.....	56
6.4	Mass balance .....	56
6.5	Predictive emissions monitoring systems (PEMS) .....	57
6.6	Emission factors.....	57
6.7	Engineering estimates.....	57
7	References .....	58

## List of Figures

Figure 1.	Use of different ranks of coal .....	31
Figure 2.	Potential mercury transformations during combustion and post-combustion (Galbreath and Zygarlicke, 2000).....	33
Figure 3.	Process diagram of a typical configuration of coal fired power plant in Japan (Ito et al., 2006).....	36
Figure 4.	Mercury concentrations in flue gas from coal-fired power plants with SCR+ESP+FGD and SCR+LLT-ESP+FGD.....	37
Figure 5.	Mercury removal by ESP as a function of the amount of unburned carbon (LOI%) in fly ash (Senior and Johnson, 2008).....	39
Figure 6.	Possible effect of coal blending on mercury capture in dry FGD .....	43
Figure 7.	Performance of bromine- and chlorine-based additives with different coals (PRB-subbituminous coal; TxL-lignite coal; NDL-lignite coal) .....	44
Figure 8.	Illustration of flue gas mercury absorption/desorption across WFGD (Keiser et al., 2014).....	45
Figure 9.	Testing of mercury removal efficiency as a function of untreated ACI rate.....	47
Figure 10.	Comparison of untreated ACI and treated ACI performance for mercury removal .....	48

## List of Tables

Table 1.	Mercury content in coals (mg/kg).....	32
Table 2.	Overview of co-benefit mercury removal in APCSs .....	35
Table 3.	Comparison of properties of subbituminous and bituminous coals .....	37
Table 4.	Costs of air pollution control devices in power plants, China (Ancora et al., 2015) .....	38
Table 5.	Capital cost of co-benefit technology in United States (\$/kW, 2012 dollars) (US EPA, 2013) .....	42
Table 6.	Costs of APCS combinations apportioned to different pollutants for a 600MW unit, China (million CNY) .....	46
Table 7.	Relative cost of mercury removal for various methods (UNEP, 2010) .....	49
Table 8.	Capital cost of ACI in United States (\$/kW, 2007 dollars) .....	50
Table 9.	Operating costs for activated carbon injection systems (on a 250 MW plant) followed by either ESP or fabric filter for bituminous coals (IJC, 2005) .....	510
Table 10.	Relative cost of mercury removal for various methods .....	50
Table 11.	Capital cost of ACI in United States (\$/kW, 2007 dollars).....	51
Table 12.	Operating costs for activated carbon injection systems (on a 250 MW plant) followed by either ESP or FF for bituminous coals (IJC, 2005) .....	51

---

**List of acronyms and abbreviations**

APCS	Air pollution control system
BAT	Best available technique
BEP	Best environmental practice
COP	Conference of parties
ESP	Electrostatic precipitator
FF	Fabric filter
FGD	Flue gas desulfurization
ID	Induced draft
O&M	Operation and maintenance
PAC	Powdered activated carbon
PC	Pulverized coal
PM	Particulate matter (sometimes called dust)
SCR	Selective catalytic reduction
UBC	Unburned carbon

## 1 Introduction

This section provides guidance on best available techniques (BAT) and best environmental practices (BEP) for controlling and, where feasible, reducing mercury emissions from coal-fired power plants and coal-fired industrial boilers, which are covered by Annex D of the Convention.

Coal-fired power plants and coal-fired industrial boilers are a large source of local, regional, and global atmospheric mercury emissions, emitting over 470 metric tons of mercury worldwide (UNEP, 2013a). Coals used for combustion throughout the world contain trace amounts of mercury that, when uncontrolled, are emitted (along with other pollutants) during the combustion process.

Most coal-fired power plants are large electricity-producing plants; some also supply heat (combined heat and power plants, district heating, etc.). Industrial boilers provide the heat or process steam necessary for local production at a facility where they are installed. Boilers in coal-fired power plants typically consume more coal than the majority of coal-fired industrial boilers, with a potential increase in mercury emissions. However, the number of industrial boilers is usually larger than the number of power plants. Another difference is that coal-fired power plant boilers are mostly single fuel, while coal-fired industrial boilers are often designed for and use a more diverse mix of fuels (e.g., fuel by-products, waste, wood) in addition to coal (Amar et al., 2008).

From the standpoint of their technical feasibility, the same technologies can be used for controlling mercury emissions from all coal-fired boilers, whatever their function. In a number of countries, power plants and large industrial boilers are already equipped with air pollution control systems (APCSs) as a result of air pollution policies. Even when not designed for mercury capture, these APCSs are capable of capturing some of the mercury output from combustion with the direct effect of reducing the release of mercury to the atmosphere (the so-called mercury co-benefit of APCSs). Smaller coal-fired industrial boilers, on the other hand, are often not equipped with efficient emission control devices, and this will affect the consideration of how to address mercury emissions from these plants.

Several factors affect the amount of mercury that might be emitted by similar plants burning comparable amounts of coal. These factors include:

- Mercury concentration in coal
- Coal type and composition
- Type of combustion technology
- Presence and mercury removal efficiency of an APCS

The above factors will be considered in the remainder of this document in greater detail in the context of BAT/BEP determination.

## 2 Processes used in coal-fired power plants and coal-fired industrial boilers, including consideration of input materials and behaviour of mercury in the process

### 2.1 Coal properties

Coal is a complex energy resource that can vary greatly in its composition, even within the same seam. The quality of coal is determined by its composition and energy content. Ranking of coal is based on the degree of transformation of the original plant material to carbon. The American Society for Testing and Materials (ASTM) defines four basic types of coal: lignite, subbituminous, bituminous, and anthracite (ASTM D388). In some countries lignite and subbituminous coal are termed “brown coal”, and bituminous and anthracite coal “hard coal”. The ASTM nomenclature will be used throughout this document.

**Lignite** typically contains 25–35 per cent fixed carbon (w/w) and has the lowest energy content (below 19.26 MJ/kg gross calorific value). It is generally used for electricity generation or district heating in the vicinity of the mines.

**Subbituminous coal** typically contains 35–45 per cent fixed carbon (w/w) and has a heating value between 19.26 and 26.80 MJ/kg gross calorific value. It is widely used for electricity generation, and also in industrial boilers.

**Bituminous coal** contains 45–86 per cent fixed carbon (w/w) and has a heating value between 26.80 and 32.66 MJ/kg gross calorific value. Like subbituminous coal, it is widely used to generate electricity and in industrial boilers.

**Anthracite** contains a very large amount of fixed carbon, as high as 86–97 per cent (w/w). It is the hardest coal and gives off the greatest amount of heat when burned (more than 32.66 kJ/kg gross calorific value). It is the most difficult coal fuel to burn, however, owing to its low volatile content.

Figure 1 presents typical use of different types of coal (WCA, 2014). As shown in that Figure 1, combined bituminous and subbituminous coals used in electricity-generating power plants and in industrial boilers are estimated to constitute over 80 per cent of known coal reserves worldwide.

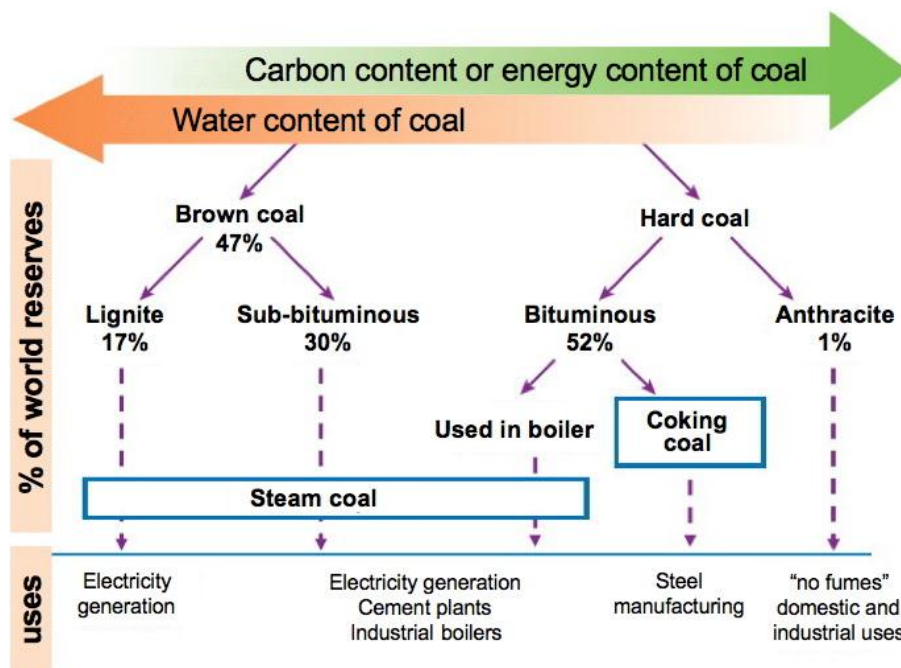

Figure 1. Use of different ranks of coal (WCA 2014)

Mercury content is a key parameter affecting the amount of uncontrolled mercury emission. Table 1, adopted from Tewalt et al. (2010), presents publicly available data on the mercury content of coal.

**Table 1**

Mercury content in coals (mg/kg)

Country	Coal type	Average of all samples	Range	Reference
Australia	Bituminous	0.075	0.01-0.31	Nelson, 2007; Tewalt et al., 2010
Argentina	Bituminous	0.19	0.02-0.96 (8)	Finkelman, 2004; Tewalt et al., 2010
Botswana	Bituminous	0.10	0.04-0.15 (28)	Finkelman, 2004; Tewalt et al., 2010
Brazil	Bituminous Subbituminous	0.20 0.3	0.04-0.81 (23) 0.06-0.94 (45)	Finkelman, 2004; Tewalt et al., 2010
Canada		0.058	0.033-0.12 (12)	Tewalt et al., 2010
Chile	Bituminous Subbituminous	0.21 0.033	0.03-2.2 (19) 0.022-0.057 (4)	Tewalt et al., 2010
China	Bituminous/Subbituminous	0.17	0.01-2.248 (482)	Zhang et al., 2012; UNEP, 2011
Colombia	Subbituminous	0.069	>0.02-0.17 (16)	Finkelman, 2004
Czech Rep.	Lignite Bituminous	0.338 0.126	<0.03-0.79 (16) 0.03-0.38 (21)	Finkelman, 2003 Tewalt et al., 2010
Egypt	Bituminous	0.12	0.02-0.37 (24)	Tewalt et al., 2010
France	Bituminous	0.044	0.03-0.071 (3)	Tewalt et al., 2010
Germany	Bituminous Lignite	0.05	0.7-1.4 Max: 0.09	Pirrone et al., 2001 MUNLV 2005
Hungary	Bituminous Subbituminous Lignite	0.354 0.138 0.242	0.091-1.2 (5) 0.04-0.31 (19) 0.075-0.44 (12)	Tewalt et al., 2010
India	Bituminous Lignite	0.106 0.071	0.02-0.86 (99) 0.053-0.093 (8)	Tewalt et al., 2010; UNEP, 2014
Indonesia	Lignite Subbituminous	0.11 0.03	0.02-0.19 (8) 0.01-0.05 (78)	Finkelman, 2003; Tewalt et al., 2010 US EPA, 2002
Iran	Bituminous	0.168	0.02-0.73 (57)	Tewalt et al., 2010
Japan	Bituminous	0.0454	0.01-0.21 (86)	Ito et al., 2004
Kazakhstan	Bituminous	0.08	<0.03-0.14 (15)	Tewalt et al., 2010
New Zealand	Bituminous Subbituminous	0.073 0.082	0.03-0.1 (5) 0.062-0.13 (9)	Tewalt et al., 2010
Mongolia	Bituminous	0.097	0.02-0.22 (36)	Tewalt et al., 2010
Peru	Anthrac+Bituminous	0.27	0.04-0.63 (15)	Finkelman, 2004
Philippines	Subbituminous	0.04	<0.04-0.1	Finkelman, 2004
Poland	Bituminous	0.085	0.013-0.163	Bojkowska et al., 2001
Romania	Lignite+Subbituminous	0.21	0.07-0.46 (11)	Finkelman, 2004
Russia	Bituminous/ Subbituminous	0.12	<0.02-0.25 (23)	UNEP, 2013b Romanov et al., 2012
Slovak Rep.	Bituminous Lignite	0.08 0.057	0.03-0.13 (7) 0.032-0.14 (8)	Finkelman, 2004 Tewalt et al., 2010
South Africa		0.157	0.023-0.1 (40)	Leaner et al., 2009; Tewalt et al., 2010
Tanzania	Bituminous	0.12	0.03-0.22 (75)	Finkelman, 2004
Thailand	Lignite	0.137	0.02-0.6 (23)	Tewalt et al., 2010
Turkey	Lignite	0.12	0.03-0.66 (149)	Tewalt et al., 2010
United Kingdom	Bituminous Subbituminous	0.216 0.1	0.012-0.6 (84) 0.01-8.0 (640)	Tewalt et al., 2010 US EPA, 1997
USA	Lignite Bituminous Anthracite	0.15 0.21 0.23	0.03-1.0 (183) <0.01-3.3 (3527) 0.16-0.30 (52)	US EPA, 1997 US EPA, 1997 US EPA, 1997



Country	Coal type	Average of all samples	Range	Reference
Vietnam	Anthracite	0.348	<0.02-0-34 (6)	Tewalt et al., 2010
Zambia	Bituminous	0.6	<0.03-3.6 (14)	Tewalt et al., 2010
Zimbabwe	Bituminous	0.08	<0.03-0.15 (6)	Tewalt et al., 2010

Note: Caution should be used when interpreting the above mercury concentration information, as populations of coal samples for different countries vary widely. In addition, information is not universally available to indicate whether the reported concentrations of mercury are based on dry coal or as-received coal figures. These data may not be representative of coal from the as-burned standpoint. The number in parentheses in the 'range' column reflects the number of samples.

## 2.2 Mercury transformations during combustion of coal

The principal combustible constituents of coal are elemental carbon and hydrogen, and their compounds.

The physical and chemical transformations that mercury undergoes during coal combustion, and subsequently in the resulting flue gas, are shown schematically in Figure 2 (Galbreath and Zygarlicke, 2000). Mercury is associated primarily with the inorganic mineral components of coal, although an association with the organic components of coal as organo-mercuric compounds has been suggested (Swaine, 1990; Groen and Craig, 1994; Finkelman, 1994). Accordingly, pyrite ( $\text{FeS}_2$ ) is the dominant mineral host for mercury in coal. In rare cases with anomalous mercury enrichment, cinnabar ( $\text{HgS}$ ) may also be present (Kolker et al. 2006; Kolker, 2012 and references therein). As the mineral (and possibly organo-mercuric) hosts of mercury decompose during combustion ( $>1400\text{ }^\circ\text{C}$ ), mercury evolves as elemental mercury ( $\text{Hg}^0$ ). The mode of occurrence of mercury in coal does not affect this initial combustion transformation mechanism.

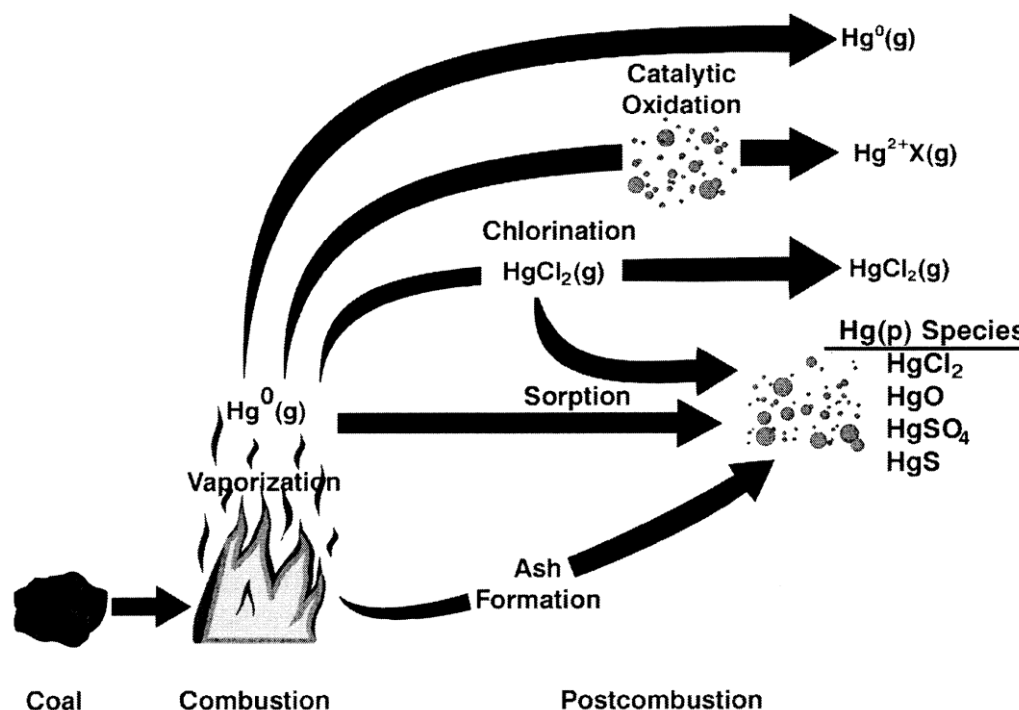

**Figure 2.** Potential mercury transformations during combustion and post-combustion (Galbreath and Zygarlicke, 2000)

Mercury emissions from coal-fired boilers can be classified into three main forms: gaseous elemental mercury ( $\text{Hg}^0$ ), gaseous oxidized mercury ( $\text{Hg}^{2+}$ ), and particulate-bound mercury ( $\text{Hg}_p$ ), which may be elemental or oxidized mercury. The relative amounts of these three main forms of mercury in the flue gases are the so-called mercury speciation. Mercury bromination or chlorination is assumed to be the dominant mechanism of mercury chemical transformation affecting the speciation of mercury. Other potential mechanisms involve mercury interactions with ash particle surfaces where reactive chemical species, catalysts, and active sorption sites are available to convert elemental to oxidized mercury, and also elemental and oxidized mercury to particulate-bound mercury (Galbreath and Zygarlicke, 2000).

Gas phase oxidation occurs primarily via chlorine species originally present in the coal, as the gases cool down through the air preheater and air pollution control devices. The extent of gas phase mercury oxidation is highly dependent upon the coal rank, the concentration of chlorine present in the coal, and the operating conditions of the boiler (e.g., air-to-fuel ratio and temperature). For example, a study of mercury speciation measurements from 14

different coal combustion systems reported from 30 to 95 per cent oxidized mercury upstream of the air pollution control devices (Prestbo and Bloom, 1995). A literature survey reveals that mercury oxidation falls primarily in the range of 45–80 per cent, with the oxidized form of mercury mostly being mercury chloride (Senior et al., 2004).

Different combustion or firing methods of coal are used in power plants and industrial boilers. These methods include:

- Suspension firing of pulverized coal (pulverized coal firing)
- Stoker firing (i.e., firing on a slowly moving or fixed grate)
- Fluidized bed firing (in either a bubbling type or a circulating fluidized bed)
- Cyclone firing of crushed coal

Most large steam generation at power plants is produced through the pulverized coal firing. In a pulverized coal boiler, finely ground coal is pulverized to a fine powder and blown directly to individual burners where it is mixed with preheated combustion air and combusted in a flame. The heat energy from the combustion process is used to produce steam, which drives a turbine-generator set to produce electricity. Field tests indicate that the speciation profile varies considerably among the tested pulverized coal boilers (Wang et al., 2010).

Stoker firing is still in use in some parts of the world, mostly in smaller boilers. In stoker firing, heated air passes upward through apertures in the grate. Dampers are positioned in under-grate zones in order to achieve proper biasing of the airflow. Over-fire combustion (air added above the grate) adds turbulence to gases coming from the grate and supplies the required air for the portion of fuel that burns in suspension. In general, stokers produce less particulate matter (PM) per unit of fuel fired, and coarser particulates compared with pulverized coal firing, because combustion takes place in a quiescent fuel bed without significant ash carry-over into the exhaust gases.

Fluidized bed firing is particularly useful for handling low-grade coals (no need for drying). In a fluidized bed combustor of the bubbling-bed type, coal particle size and vertical air velocity are regulated to establish a discrete horizontal plane that divides the active bed from the entrained-flow open furnace above. The basic mechanism for the control of bed temperature and heat transfer to the walls of the combustor, and to any immersed heating surface in the bed of a fluidized-bed boiler, is the variation in the total solids inventory. The temperature in a fluidized-bed combustor is controllable in a narrow range. On-site measurement of mercury concentrations from a circulating fluidized bed boiler shows that particulate mercury is the dominant mercury species in the boiler's flue gas (Duan et al., 2010).

In cyclone firing, crushed (but not pulverized) coal is burned in a swirling combustion chamber at high temperatures, making a liquid slag out of most of the mineral matter in the coal. The hot gases then enter the furnace where they radiate heat to the furnace walls and convect heat to generated steam, which drives a turbine generator set to produce electricity. Cyclone boilers generate less fly ash per unit coal burned than pulverized coal boilers, because most of the mineral matter in a cyclone boiler becomes a liquid slag that is collected from the bottom of the cyclonic combustion chamber.

### 3 Menu of mercury emission reduction techniques

This section describes mercury emission reduction approaches and control technologies that could be considered for the determination of BAT by a given party or facility (see section 5 below). They include coal treatment, co-benefit mercury removal, and technologies dedicated to the removal of mercury.

#### 3.1 Coal washing

Coal washing reduces ash content and improves its heating value, thus increasing boiler efficiency (Satyamurty, 2007). Coal washing, while primarily targeting the minimization of ash and sulfur content of coal, can also decrease the mercury content of coal, and this is already done in some cases. Raw coal contains mineral impurities such as rock and clay that are referred to as ash. Where appropriate, this raw coal should be processed (or cleaned) to reduce the ash content, to increase the heating value, and to reduce the particulate matter (PM), sulfur and, potentially, mercury content to ultimately lower emissions when the coal is burned in the boiler. In addition, the removal of mineral impurities also reduces operation and maintenance costs and slows the deterioration of the boiler system. It should be noted, however, that most lignite and brown coals are not amenable to conventional coal washing (Institution of Chemical Engineers, 1997).

Conventional coal washing methods may also remove some of the mercury associated with the incombustible mineral materials. However, they will typically not remove the mercury associated with the organic carbon structure of the coal (USEPA, 2002). One review quotes test data for 26 bituminous coal samples from the United States with a wide range in the amount of mercury removed by coal washing (USEPA, 1997). This trend was confirmed by another study (USGS, 2014), which concluded that coal washing was effective in reducing the concentrations of pyrite-associated elements such as mercury. Yet another study reported average mercury reduction on an energy basis of 37 per cent (Toole-O'Neil et al., 1999).

The variation in mercury reductions quoted above might be a function of the type of process used to wash a given coal, the coal rank, and the nature of mercury in the coal matrix. In summary, removal of some of the mercury from coal is feasible when conventional coal washing methods are used. The effectiveness of mercury removal during conventional coal washing, however, varies widely depending on the source of the coal and on the nature of the mercury within it.

##### *Cross-media effects of coal washing*

Coal washing generates waste slurry which contains mercury. There is potential soil or groundwater contamination if coal washing slurry is not safely managed

#### 3.2 Contribution of APCSs in terms of mercury removal

The APCSs installed primarily for control of SO<sub>2</sub>, NO<sub>x</sub>, or particulate matter (PM) remove mercury from the flue gas. This is called the co-benefit mercury removal. Co-benefit mercury removal by non-mercury air pollution control equipment is most often accomplished in two fundamental modes: removal of oxidized mercury in a wet flue gas desulfurization (wet FGD) scrubber and removal of PM-bound mercury in a PM control device, such as an electrostatic precipitator (ESP) or fabric filter (FF). Co-benefit removal of mercury can also be accomplished in spray dryer absorbers. Depending on the configuration of pollution control equipment, varying amounts of mercury removal could be accomplished. An overview of the magnitude of co-benefit mercury removal for different configurations of existing APCSs is provided in Table 2 (Srivastava et al., 2006; EIPPCB, 2013). It should be noted that the co-benefit removal as shown in Table 2 will vary depending on coal properties and operational parameters of the APCS.

**Table 2**

Overview of co-benefit mercury removal in APCSs

Existing control equipment	Qualitative mercury capture
ESPC only	Good capture of particulate-bound; better capture for high chlorine coals than low rank coals.
ESPh only	Low capture
FF only	Good capture of oxidized mercury
ESPC + wet FGD	Generally, good capture for high chlorine coals thanks to presence of soluble oxidized mercury in the flue gas. Relatively poor capture for low rank coals. Elemental mercury re-emission may decrease the amount of co-benefit.
ESPh + wet FGD	Generally, good capture for high chlorine coals thanks to presence of soluble oxidized mercury in the flue gas. Relatively poor capture for low rank coals. Elemental mercury re-emission may decrease the amount of co-benefit.
SDA + FF	Generally good capture for high chlorine coals; less co-benefit capture expected for low rank coals.

FF + Wet FGD	Generally, good capture for high chlorine coals thanks to presence of soluble oxidized mercury in the flue gas. Relatively poor capture for low rank coals. Elemental mercury re-emission may decrease the amount of co-benefit. Elemental mercury may be oxidized across the FF and captured in the wet scrubber.
SCR + ESPc	Good capture of particulate-bound mercury, better capture for high chlorine coals than low rank coals
SCR + ESPh	Low capture
SCR + ESPc + wet FGD	Good capture for high chlorine coals thanks to increased amount of soluble oxidized mercury in the flue gas which is promoted by the SCR. Improved capture for low rank coals thanks to greater amount of soluble oxidized mercury in the flue gas. Elemental mercury re-emission may decrease the amount of co-benefit. Good capture of particulate-bound mercury.
SCR + HEX + LLT-ESP + wet FGD	Very high capture for high chlorine coals thanks to increased amount of soluble oxidized mercury in the flue gas which is promoted by the SCR. Improved capture for low rank coals thanks to greater amount of soluble oxidized mercury in the flue gas. Elemental mercury re-emission may decrease the amount of co-benefit. Combination of heat exchanger and low-low temperature ESP enhances capture of particulate and vapour phase mercury.
SCR + SDA + FF	Generally good capture for high chlorine coals, less for low rank coals. SCR enhances capture by oxidizing elemental mercury to oxidized mercury form, given availability of chlorine in the flue gas.
SCR + ESPh + wet FGD	Good capture for high chlorine coals thanks to increased amount of soluble oxidized mercury in the flue gas which is promoted by the SCR. Improved capture for low rank coals thanks to greater amount of soluble oxidized mercury in the flue gas. Elemental mercury re-emission may decrease the amount of co-benefit.
SCR + FF + wet FGD	Good capture for high chlorine coals thanks to increased amount of soluble oxidized mercury in the flue gas which is promoted by the SCR. Improved capture for low rank coals thanks to greater amount of soluble oxidized mercury in the flue gas. Elemental mercury re-emission may decrease the amount of co-benefit. Good capture of particulate-bound mercury;

**Key:**

ESP = electrostatic precipitator; ESPc = cold side ESP; ESPh = Hot side ESP; FF = fabric filter; SCR = selective catalytic reduction; SDA = spray dryer absorber (dry scrubber); Wet FGD = wet flue gas desulfurization scrubber; HEX = heat exchange; LLT-ESP= low-low temperature ESP

Low means less than 30 per cent control, high/good means more than 70 per cent control, moderate means 30 to 70 per cent control.

One of the APCS configurations presented in Table 2 (SCR+ESPc+FGD) is shown schematically in Figure 3 below (Ito et al., 2006). For example, such a combination in Japan achieved an average mercury removal efficiency of 74 per cent (Ito et al., 2006). Co-benefit techniques can, therefore control multiple air pollutants, including mercury.

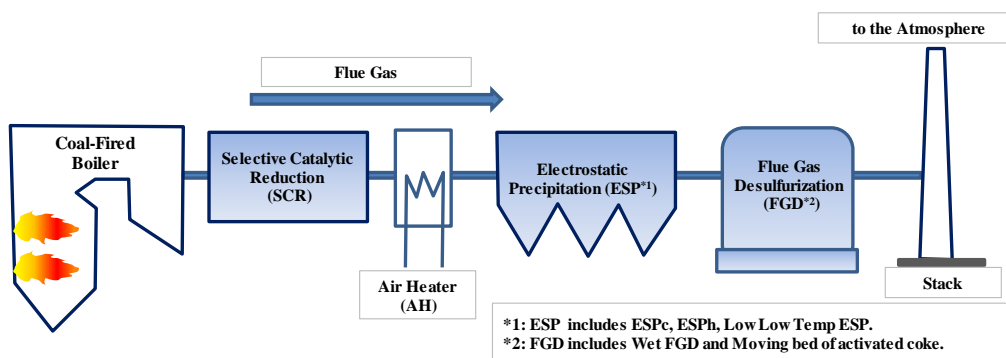
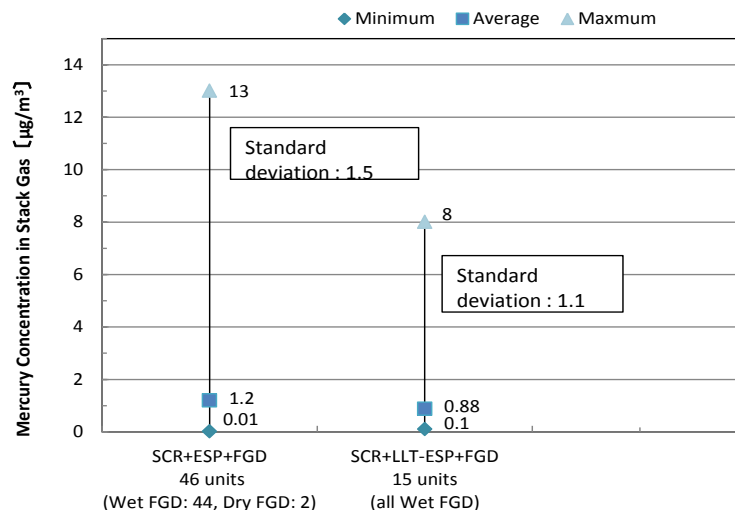

**Figure 3. Process diagram of a typical configuration of coal-fired power plants in Japan (Ito et al., 2006) (revised)**

High-level co-benefit removal of mercury can be achieved by combining selective catalytic reduction (SCR), cold side electrostatic precipitator (ESPc) and flue gas desulfurization scrubber (FGD). The combination of these techniques is quite typical at advanced coal-fired power plants in some countries and is widely used, for example in Japan, as shown in Figure 3. The combination of SCR, ESP and FGD as shown in these examples can achieve removal efficiencies of 50–90 per cent for NO<sub>x</sub>, more than 99 per cent for PM, and 76–98 per cent for SO<sub>2</sub>, along with high-level mercury removal efficiency at on average 74 per cent, which results in 1.2 µg/m<sup>3</sup> of mercury concentration in the flue gas in this example. Furthermore, the combination of SCR, low-low temperature ESP (LLT-ESP), whose operating temperature is 90°C, and wet FGD can achieve mercury removal efficiency of quite a high level, at on average 87 per cent, which results in 0.88 µg/m<sup>3</sup> of mercury concentration in the flue gas for this specific case. The LLT-ESP, which requires flue gas cooling, improves particulate control through reduced gas volume and lower ash

resistivity due to SO<sub>3</sub> condensation and moisture adsorption to fly ash, and increases mercury adsorption on fly ash due to lower flue gas temperature. It also avoids costs associated with flue gas reheat or wet stack retrofits. In cases where reheating wet FGD exhaust is not needed, the recovered heat can be used in the boiler or steam turbine to improve the efficiency of the unit, thus increasing net output (Nakayama et al, 2006, Iwatsuki et al 2008).

The mercury concentrations in figure 4 show a wide range. This is because these units include older or smaller units which provide the higher concentrations. On the other hand, the two units with the moving bed of active coke (Peters, 2010), which is a dry FGD, show higher performance than the wet FGD. The performance is higher than the combination with the LLT-ESP and the wet FGD (CRIEPI and FEPC, 2012).



Note: ESP in SCE+ESP+FGD includes ESPh includes ESPh, ESPc and LLT-ESP

Operating temperature ESPh 300–400°C, ESPc 130–180°C, LLT-ESP 90–100°C

**Figure 4. Mercury concentrations in flue gas from coal-fired power plants with SCR+ESP+FGD and SCR+LLT-ESP+FGD**

Table 3 summarizes the mercury removal efficiencies of APCDs for coal combustion plants in China. It shows that, in some cases, the combination of ESP and wet FGD achieves mercury removal efficiencies of up to 88 per cent. The combination of SCR, ESP and wet FGD, which is widely used in Chinese coal-fired power plants, can accomplish a higher mercury removal efficiency, for example, of up to 95 per cent. High mercury removal efficiencies are also observed for the combination of SCR, FF and wet FGD.

**Table 3**

Mercury removal efficiency by typical APCD combinations in China (in percentages) (Zhang et al., 2015)

APCD combination	Mean	Min	Max	Standard Deviation	Number of tests
Wet PM Scurbber	23	7	59	18	8
ESPc	29	1	83	19	64
FF	67	9	92	30	10
ESPc+wFGD	62	13	88	22	19
FF+wFGD	86	77	97	10	3
SCR+ESP+wFGD	69	36	95	24	4
SCR+FF+wFGD	93	86	99	9	2
ESPc+CFB-FGD+FF	68	68	68		1

Table 4 below shows measurement values of mercury emissions for different coal-fired power plants, achieved through co-benefits for pollution controls. The selected examples in this table show that co-benefit control techniques in some cases achieve low mercury concentrations in the flue gas.

**Table 4**

Emission levels achieved with co-benefit techniques (data compiled by ZMWG, 2015)

<i>Plant</i>	<i>Coal type</i>	<i>Emission level (<math>\mu\text{g}/\text{Nm}^3</math>) (normalized to 6 % <math>\text{O}_2</math>-content)</i>	<i>Boiler size (MWh)</i>	<i>Flue gas treatment technique</i>
Federico II – Brindisi, Italy	hard coal	0.69	1,700	ESP+SCR+wFGD
Torrevaldaliga Nord, Italy	hard coal	0.99	1,420	FF+SCR+wFGD
Impianto termoelettrico di Fusina, Italy	hard coal	0.8	431	FF+SCR+wFGD
Heyden, Germany	hard coal	0.5	2,150	ESP+SCR+wFGD
FHKW Mellach, Austria	hard coal	0.5	543	FF+SCR+wFGD
Brindisi BR III & BR II, Italy	hard coal	0.5	857	ESP+SCR
Krefeld, Currenta , Germany(Industrial boiler)	hard coal	0.2	105	FF
Salem Harbour, USA	hard coal	0.2-0.4	300	ESP
Power plant Tusimice, Czech	lignite	2.6	890	ESP+wFGD
Neurath, A and F, Germany	lignite	3.0	855	ESP+wFGD
Teplarna Tabor, Czech	lignite	3.3	199	ESP

Note: all values are based on periodic samples except for Salem Harbour, which is based on continuous emissions monitoring. Data are for the year 2010.

### 3.2.1 Particulate matter control devices

Two major types of PM control devices include ESPs and FFs. Wet PM scrubbers are also used at coal-fired boilers.

#### 3.2.1.1 Electrostatic precipitators (ESPs)

ESPs are typically designed to achieve greater than 99 per cent PM collection efficiencies, subject to various factors presented in the introductory section. The PM collection efficiency of an ESP is also a function of the sulfur content of coal, which affects the resistivity of fly ash. Coal that contains a moderate-to-high amount of sulfur produces an easily collected fly ash. Lower sulfur coal produces a higher resistivity fly ash that is more difficult to collect. Resistivity of the fly ash can be changed by decreasing the temperature in the ESP or by conditioning the particles upstream of the ESP with sulfur trioxide ( $\text{SO}_3$ ), sulfuric acid ( $\text{H}_2\text{SO}_4$ ), water, sodium, or ammonia ( $\text{NH}_3$ ).

For a given coal fly ash, the effectiveness of PM collection efficiency by an ESP is a function of particle size. Particles larger than about  $1\ \mu\text{m}$ – $8\ \mu\text{m}$  are typically collected with efficiencies from 95 to 99.9 per cent. However, particles near the  $0.3\ \mu\text{m}$  size are in a poor charging region that reduces collection efficiency to 80–95 per cent (Lawless, 1996).

An ESP can be used at one of two locations in a boiler system: the so-called “cold-side” ESP (ESPC) and “hot-side” ESP (ESPh). An ESPC is installed downstream of the air heater (flue gas temperature between  $130\ ^\circ\text{C}$  and  $180\ ^\circ\text{C}$ ). An ESPh is installed upstream of the air heater (flue gas temperature between  $300\ ^\circ\text{C}$  and  $400\ ^\circ\text{C}$ ) and makes it possible to take advantage of the lower fly-ash resistivity at higher temperatures. This is particularly important for units burning low-sulfur coal, resulting in fly ash with higher electrical resistivity. The wet ESP is a new type of ESP, which has higher removal efficiency for fine particles (Altman et al., 2001; Staehle et al., 2003). However, on-site measurements have not yet been conducted for mercury removal inside a wet ESP.

Varying levels of mercury removal have been observed for ESPs. The level of mercury removal depends on whether it is an ESPC or ESPh installation, the type of coal burned, the type of boiler, and other factors such as sulfur content in coal and the level of unburned carbon in the fly ash. An ESPh is generally much less effective than an ESPC at removing mercury. For example, while the average reported mercury removal for an ESP operating on bituminous coal was about 30 per cent, the range of measured removals varied from 0 to about 60 per cent (US EPA, 2001). The range of measured mercury removals, especially for the ESP, may be an indicator of the potential for improvement of mercury capture resulting from the increased efficiency of a PM collector. It is important to understand the PM collection performance of a device since this in turn affects the device’s capability to reduce mercury emissions.

Fundamental modelling of mercury removal in ESPs indicates that mass-transfer limitations, even under idealized conditions, may restrict the potential for mercury capture by PM collected on electrodes in an ESP (Clack, 2006 and Clack, 2009). ESPs remove only  $\text{Hg}_\text{p}$  in the process of collecting PM.  $\text{Hg}_\text{p}$  is preferentially bound to unburned carbon (UBC). The mercury adsorption capacity of inorganic fractions (fly ash) is typically low compared to the UBC present in fly ash. A relationship between the amount of UBC and mercury removal across ESPC has been observed for

bituminous coal fly ash (Senior and Johnson, 2008). This behaviour is shown in Figure 5, which shows the percentage capture (percentage of mercury incoming to the ESP) as a function of the amount of UBC. In figure 5, UBC is expressed as the measured loss on ignition (LOI). As can be seen, mercury capture of between 20 and 40 per cent was found in an ESP capturing fly ash containing about 5 per cent UBC. With higher UBC content, mercury capture of as much as 80 per cent could be seen; likely a function of the halogens present (Vosteen et al., 2003).

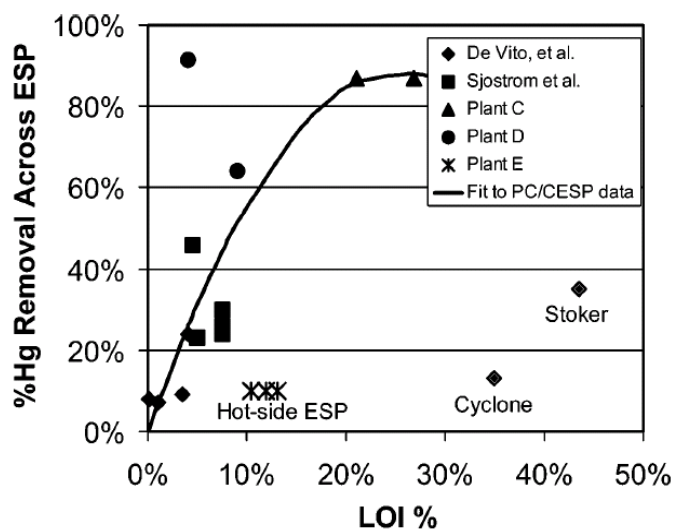

**Figure 5. Mercury removal by ESP as a function of the amount of unburned carbon (LOI%) in fly ash (Senior and Johnson, 2008)**

In addition to the amount of UBC, the properties of UBC such as surface area, particle size, porosity, and chemical composition may also affect the amount of mercury captured in an ESP (Lu et al., 2007). This study found that while UBC content in fly ash decreased with decreasing particle size, the mercury content of UBC generally increased with decreasing particle size. In addition, the particle size of UBC was found to be the major factor affecting mercury adsorption. Thus, increased efficiency of an ESP and the resultant increase in the capture of fine fly ash and fine UBC will likely cause a decrease in mercury emissions. It should be noted, however, that most of the mass of UBC is in very large particles.

Other important factors governing the amount of mercury that is captured in fly ash (and subsequently removed from the flue gas) are the type of ESP used (e.g. ESPc or ESPh), the use of  $\text{SO}_3$  as a flue gas conditioning agent, and the type of coal. Typically, higher mercury capture is observed in ESPs installed on boilers burning coals with higher halogen contents and producing higher levels of UBC in the flue gas. Both of these parameters promote the formation of oxidized mercury and PM-bound mercury, which are easier to capture in the ESP than elemental mercury. It follows that, if the performance of the ESP can be improved, an additional amount of mercury could be removed from the flue gas. The amount of this additionally removed mercury would be a function of the amount of additional PM removed by the ESP. Low-cost approaches such as accurate alignment of plates, adjustment of rapping pattern, elimination of in-leakages, among other approaches, can be used to improve the PM collection efficiency of ESPs (Zykov et al., 2004; Deye and Layman, 2008). Low temperatures in the control device system (below 150 °C) also enhance mercury control and LLT-ESP has been practiced in Japan to achieve higher removal efficiency of dust and mercury (CRIEPI and FEPC, 2012).

It should be noted that the positive effects of  $\text{SO}_3$  on particulate capture may be partially offset by the competition of  $\text{SO}_3$  with mercury for adsorption on the fly ash.

### 3.2.1.2 Fabric filters (FFs)

FFs provide higher removal efficiency of fine particles in comparison to ESPs, in particular submicron particles.

Higher removals of mercury are generally observed in FFs than in ESPs. FFs are more effective in removing fine PM (most importantly, submicron PM) than ESPs, and they tend to remove more of the gas-phase mercury than ESPs. In addition to longer contact time, better contact is provided in a FF (gas penetrates through the filter cake) than in an ESP (gas passes over the surface of the cake). The result is that gaseous elemental mercury is more likely to be oxidized and transformed into a form that can be captured when a FF is used. For example, a study comparing the capture of mercury in ESPs and FFs in coal-fired power plants in China revealed between 1 and 83 per cent capture in ESPs and between 9 and 92 per cent capture in FFs (Zhang et al., 2015). The average mercury removal efficiencies for ESPs and FFs in Chinese coal-fired power plants are 29 per cent and 67 per cent, respectively (Zhang et al., 2015).

FFs can also be integrated with ESPs to become ESP-FFs, which are employed in China to an extent comparable to FFs. The mercury removal efficiency of ESP-FFs is between that of ESPs and FFs. An average of 43 per cent of mercury removal can be achieved with ESP-FFs (Zhang, 2015).

### 3.2.1.3 Wet PM scrubbers

Most of the small and medium-scale industrial boilers in China are equipped with wet PM scrubbers to reduce PM emissions. A wet PM scrubber system has chemistry similar to that of wet FGD. However, conventional wet PM scrubbers simply use water as the absorbent, so the re-emission of elemental mercury is significant. On-site measurements showed an average mercury removal efficiency of 23 per cent (between 7 and 59 per cent) for wet PM scrubbers at Chinese coal-fired industrial boilers.

The integrated marble scrubber (IMS) is a special type of wet PM scrubber for concurrent PM and SO<sub>2</sub> removal, and these are more and more widely used by coal-fired power plants in China owing to their technological economy. The IMS uses alkali liquor as the absorbent, which is more effective in capturing oxidized mercury, similar to wet FGD. The efficiency of IMSs in mercury removal could be higher than that of conventional wet PM scrubbers as a consequence of its SO<sub>2</sub> control capacity, but no on-site measurements have yet been conducted.

#### *Cross-media effects for PM control devices*

There are potential cross-media effects that apply to PM control devices. Mercury in the fly ash can be re-emitted if the fly ash collected by PM control devices is heated during reuse. For example, the mercury in fly ash may be released to the air if used as the raw material in a cement kiln. There is also potential for mercury from fly ash to leach into groundwater. Sound management of fly ash collected by PM control devices is needed.

### 3.2.2 SO<sub>2</sub> control devices

There are two main techniques used for SO<sub>2</sub> emission reduction and dealt with below: first, wet FGD, and second, dry FGD, or dry scrubber.

#### 3.2.2.1 Wet flue gas desulfurization (wet FGD)

In plants equipped with wet FGD, the amount of the co-benefit removal may be augmented by the increase of the fraction of oxidized mercury in the total mercury flue gas content or by the improvement of PM control effectiveness (Sloss, 2009). The increase of the fraction of oxidized mercury can be accomplished by the addition of chemical compounds (oxidizing agents) or by the oxidation of mercury over catalysts (Amar et al., 2010). The catalyst may be placed in the flue gas for the sole purpose of mercury oxidation or may be installed for another purpose (e.g., for the control of NO<sub>x</sub> emissions) and thus provide the co-benefit. The operation of a wet FGD requires that a PM control device be installed upstream of the wet FGD scrubber (Srivastava and Jozewicz, 2001).

As mentioned before, gaseous compounds of oxidized mercury are generally water-soluble, and thus wet FGD systems are expected to capture them efficiently (Reddinger et al., 1997; DeVito and Rossenhover 1999). Gaseous elemental mercury, however, is insoluble in water and therefore does not absorb in FGD slurries. Data from actual facilities have shown that the capture of oxidized mercury averaging 75 per cent (between 67 and 93 per cent) can be expected in calcium-based wet FGD systems (Chen et al., 2007; Kim et al. 2009; Wang et al., 2010; Sloss, 2015), although there are cases where significantly less capture has been measured as a result of unfavourable scrubber equilibrium chemistry (Niksa and Fujiwara, 2004).

It has also been shown that, under some conditions, oxidized mercury may be reduced in wet FGD scrubbers to elemental mercury, which could then be re-emitted (Nolan et al., 2003). Thus, in the case of wet FGD, the optimization of the co-benefit strategy sometimes means preserving the amount of oxidized mercury in the system in order to prevent the re-emission of mercury. Mercury re-emission may take place when oxidized mercury is absorbed by the wet FGD slurry, converted to elemental mercury, and then transferred to gas phase to exit the scrubber.

The net effect of re-emission is the limitation of mercury removal by a wet FGD. The occurrence and the extent of mercury re-emission from wet FGD depend on FGD chemistry (Renninger et al., 2004). There also appears to be increased potential for the re-emission of mercury in wet FGD with appreciable mercury concentrations in the liquid phase (Chang et al., 2008). In some cases chemical agents or activated carbon needs to be added to the FGD liquor to control re-emission.

#### 3.2.2.2 Dry FGD

Spray dryers are typically used for the control of SO<sub>2</sub> emissions for sources that burn low-to-medium-sulfur coal, or for smaller coal-fired combustion plants. Up to approximately 95 per cent mercury may be removed by SDA-FF combinations when used on bituminous coal-fired boilers. Much lower mercury capture, however, (about 25 per cent) is observed in SDA-FF units on boilers firing lignite or other low-rank coals with low chlorine content (Senior, 2000). Scrubbing of halogen species in the spray dryer absorber may make oxidation and subsequent capture of mercury (mostly in the form of elemental mercury for these coals) in the downstream FF less effective. Sometimes, the



mercury capture for low rank coal accomplished by FFs alone is higher than that by SDA-FFs (Srivastava et al., 2006).

A dry desulfurization scrubber technology, in recent times increasingly used in coal combustion plants, is the circulating dry scrubber, CDS. Like the SDA scrubber, the CDS scrubber has a reaction chamber and a fabric filter for by-product and ash capture. A differentiating feature of the CDS is that reaction materials enter the reaction chamber dry and are fluidized in the reaction chamber before passing on to the fabric filter. A water spray is applied to the bottom of the reaction chamber to control the reactor temperature. The reaction materials are hydrated lime and recycled solids from the fabric filter. The CDS has a higher solids concentration than the SDA, which allows it to achieve SO<sub>2</sub> reductions of up to 98 per cent, as compared to a maximum of 95 per cent reduction by SDA scrubbers. In addition, the CDS can treat flue gas from higher sulfur coal than the SDA because SO<sub>2</sub> capture is not limited by the stoichiometry of a slurry (Ake, 2009).

Mercury capture in CDS as a co-benefit is similar in magnitude to SDA scrubbers where significant capture of oxidized mercury has been achieved. Accordingly, much higher co-benefit mercury capture can be achieved with higher chlorine coals than with low chlorine coals (Babcock Power, 2012).

#### *Cross-media effects for SO<sub>2</sub> control devices*

For the wet FGD system, retention of mercury through the FGD system requires high quality wastewater and sludge treatment to ensure that the mercury is not simply being transferred from air to water.

When the FGD gypsum is used for wallboard production, mercury contained in gypsum has the potential to be re-emitted. With an SDA-FF system, there is potential for mercury from fly ash collected by FF to leach into groundwater. Accordingly, there is a need for the sound management of fly ash collected by FFs.

#### *Cross-media effects for SO<sub>2</sub> control devices (non-mercury related)*

The operation of an FGD system generally increases energy consumption, typically by as much as 5 per cent.

### **3.2.3 Selective catalytic reduction for NO<sub>x</sub> control**

SCR technology has been designed to reduce NO<sub>x</sub> through a catalytically enhanced reaction of NO<sub>x</sub> with NH<sub>3</sub>, reducing NO<sub>x</sub> to water and nitrogen. This reaction takes place on the surface of a catalyst, which is placed in a reactor vessel. Under certain conditions, SCR catalysts have been shown to change mercury speciation by promoting the oxidation of elemental mercury to oxidized mercury, particularly for high chlorine coal. It should be noted that the SCR itself does not remove mercury. Instead, by increasing the amount of oxidized mercury the SCR improves mercury capture in PM control devices and wet FGD systems, resulting in the enhanced removal of mercury (Chu, 2004; Favale et al., 2013).

Since the operational parameters of the SCR (e.g., temperature, concentration of NH<sub>3</sub> in the flue gas, catalyst bed size, and catalyst age) will generally be dictated by the NO<sub>x</sub> control strategy, the parameter that shows the most promise for the optimization of mercury removal is the chlorine content of the coal. As discussed in the section on coal blending below which is based on United States data, oxidation of elemental mercury to oxidized mercury is greater for bituminous coals than for subbituminous coals. Thus, the maximum co-benefit of the existing SCR may be achieved by an appropriate coal-blending or by bromide addition (Vosteen et al., 2006). SCR catalysts are being designed to optimize both the NO<sub>x</sub> removal and mercury oxidation.

Use of SCR increases the extent of mercury oxidation and capture, in particular with increases of the fraction of bituminous coal in a subbituminous and bituminous coal blend. A field study at a large utility plant firing a 60 per cent subbituminous and 40 per cent bituminous blend at two identical boilers (one with SCR and the other without SCR) demonstrated an increase in the oxidized mercury fraction from 63 per cent without SCR to 97 per cent with SCR. Generally, in systems with SCR, mercury oxidation across the SCR system rises with an increasing percentage of bituminous coal in a subbituminous-bituminous coal blend. For example, for a 65:35 subbituminous-bituminous coal blend, the increase was 49 percentage points (from 13 to 62 per cent). For the 79:21 blend, however, the increase was only 14 percentage points (from 6 to 20 per cent) (Serre et al., 2008).

The unblended subbituminous coal in a unit without SCR would have achieved between 0 and 40 per cent oxidized mercury (ICAC, 2010). In another field study, tests conducted in three bituminous coal-fired plants showed mercury oxidation across the SCR of up to 90 per cent and more. The resultant mercury removal in downstream wet scrubbers was from 84 to 92 per cent with SCR operation compared to 43–51 per cent without SCR operation. Plants firing subbituminous coals, however, showed little change in mercury speciation across the SCR reactors (Laudal, 2002).

On-site measurements from four Chinese coal-fired power plants showed that the elemental mercury oxidation rate inside SCR was in the range of 34–85 per cent, affected by the total mercury and chlorine content in coal and the NH<sub>3</sub> injection rate of SCR (Zhang et al., 2013).

#### *Cross-media effects for NO<sub>x</sub> control devices*

With the mercury oxidation by SCR, there is possibility of increasing the mercury content of fly ashes and FGD gypsum. The used SCR catalyst might be hazardous in nature. The used SCR catalyst should be either regenerated or disposed of in an environmentally sound manner.

*Cross-media effects for NO<sub>x</sub> control devices (non-mercury-related)*

The operation of an SCR system generally increases energy consumption, typically up to 3 per cent.

### 3.3 Co-benefit enhancement techniques

Co-benefit enhancement may be achieved by coal blending, coal additives, or by a number of other techniques described below.

#### 3.3.1 Coal blending

Coal blending (or switching) at power plants is used as part of a strategy to meet SO<sub>2</sub> emission limits in a cost-effective manner, provided coal blending is compatible with the power plant design. Typically, high sulfur bituminous coals are blended with low sulfur subbituminous coals to lower SO<sub>2</sub> emissions. As an undesired side effect of this SO<sub>2</sub> emission control strategy, mercury speciation may be altered, reducing the amount of oxidized mercury and increasing the amount of elemental mercury, thus compromising mercury capture in a downstream FGD system. Blending of coals may also be used, however, to increase the amount of oxidized mercury in flue gas. In addition to mercury content, certain coal characteristics such as chlorine and bromine content or alkalinity content are important for mercury removal and should be known. Bituminous coals typically produce a higher fraction of oxidized mercury in the flue gas than do subbituminous coals. Since oxidized mercury is water-soluble, it is more readily captured in wet FGD systems. Consequently, the mercury capture efficiency of FGD systems depends largely on the fraction of oxidized mercury at the FGD inlet (Miller et al., 2006).

An example of coal blending that is used to improve mercury removal in downstream air pollution control equipment is discussed below. Table (UNEP, 2010) shows data on properties of typical subbituminous coal (from Wyoming, United States) and bituminous coal (from Illinois, United States). It should be noted that the properties given in Table 5 are for illustration only and will vary depending on the origin of the coal.

**Table 5**

Comparison of properties of subbituminous and bituminous coals

<i>Content</i>	<i>Subbituminous coal, wt%</i>	<i>Bituminous coal, wt%</i>
Bromine <sup>a</sup>	0.0006	0.02
Chlorine <sup>a</sup>	0.003	0.100
Sulfur <sup>a</sup>	0.37	4.00
CaO	26.67	3.43
MgO	5.30	3.07
Na <sub>2</sub> O	1.68	0.60
Hg, ppm	0.1	0.1

<sup>a</sup> ultimate analysis, as received, wt %

It should be noted from Table 5 that, even though in these averaged data, mercury content is the same at 0.1 ppm for both types of coals, chlorine content varies significantly, from 0.003 per cent by weight for subbituminous coal to 0.1 per cent for bituminous coal. In addition, alkaline material (such as CaO) content varies from 3.43 per cent for subbituminous coal to 26.67 per cent for bituminous coal by weight. This illustrates that lower chlorine content in subbituminous coals may result in lower mercury oxidation and hence a higher percentage of elemental mercury. Blending bituminous coal with subbituminous coal provides the double benefit of higher chlorine concentration and lower alkalinity. In the context of mercury control, the objective of coal blending would be to increase halogen concentration by mixing relatively high halogen content coal with low halogen coal that might be used at the plant.

Figure below shows the trend of increasing mercury capture in a dry FGD system (dry FGD plus FF) with an increasing fraction of bituminous coal in a bituminous-subbituminous coal mixture (UNEP, 2011). As can be seen, coal blending has the potential of increasing the mercury capture by up to almost 80 per cent. Again, it should be noted that incremental mercury removal values are of an illustrative nature and that actual incremental mercury removal values may vary depending on sources of the coals used for blending.

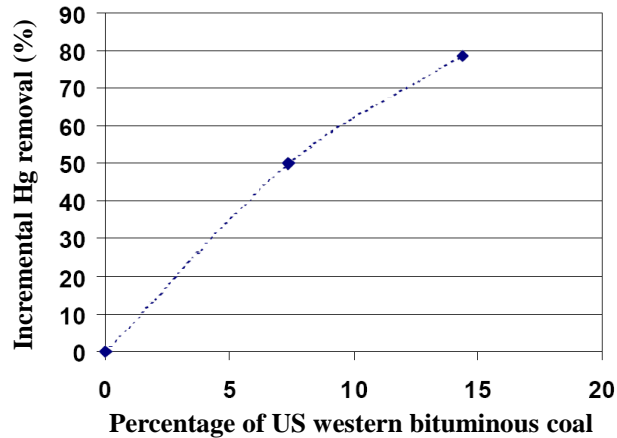

**Figure 6. Possible effect of coal blending on mercury capture in dry FGD**

Thus, blending of coal may potentially increase mercury oxidation for plants firing low chlorine, high calcium coal. The characteristics of different coal types play a major role in determining the speciation of mercury. This, in turn, can dramatically affect the amount of mercury captured in existing pollution control devices like FGD systems. The effect may be more pronounced in plants equipped with SCR systems, as will be discussed later.

### 3.3.2 Mercury oxidation additives

The amount of mercury captured generally increases as the amount of halogens in coal increases. Consequently, to promote increased capture for coals that have low halogen concentrations, additional halogens such as bromine or chlorine salts are often added. Alternatively, HCl or ammonium chloride ( $\text{NH}_4\text{Cl}$ ) may be added. Halogen additives promote formation of oxidized and particulate-bound mercury, which is more easily captured in downstream devices. Halogen additives may be particularly useful in improving mercury removal for units firing low-halogen coals. The additives may be sprayed on coal or added as solids to a coal stream either upstream of the coal pulverizer or injected into the boiler.

Bromine is thought to have an advantage over chlorine in that it interacts more actively with mercury than bromine does (Vosteen et al., 2002; Vosteen et al., 2003; Vosteen et al., 2003b; Vosteen et al., 2003c; Buschmann et al., 2005). A heterogeneous oxidation pathway is thought to be important under coal-fired flue gas conditions despite the fact that chlorine content in coal is typically much higher than that of bromine (Vosteen et al., 2006b, Rini and Vosteen, 2008, Senior et al., 2008, Vosteen et al., 2010). Full-scale tests were conducted using a 52 weight percentage water solution of calcium bromide as a pre-combustion additive at a concentration of 25 part per million (ppm) in coal equivalent level, and mercury emission reduction was increased from 55 to 97 per cent in a 600 MW unit firing subbituminous coal and equipped with an SCR system and wet FGD (Rini and Vosteen, 2009). Full-scale tests conducted by the Electric Power Research Institute of the United States at 14 units firing low chlorine coals demonstrated more than 90 per cent flue gas mercury oxidation for bromide additions, equivalent to 25–300 ppm in coal (Chang et al., 2008).



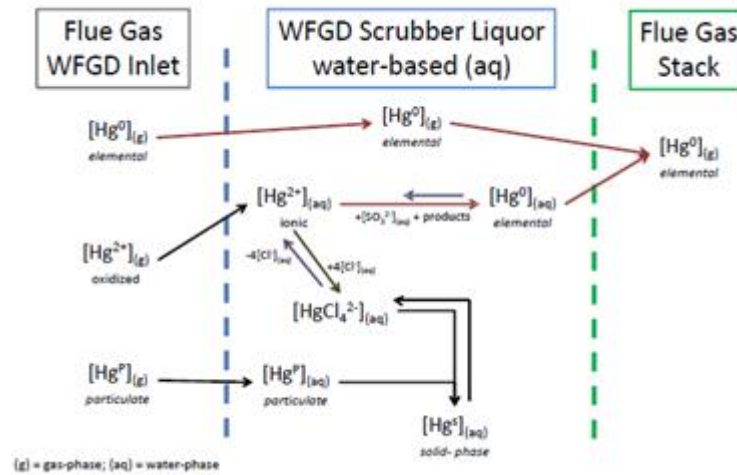

**Figure 8.** Illustration of flue gas mercury absorption/desorption across WFGD (Keiser et al., 2014)

Much effort has been put into the development of techniques and products to avoid mercury re-emission and a number of these have been commercialized. In principle, all these techniques are based on a method of reducing the soluble mercury content in the scrubber liquor. This is accomplished by either absorption of the ionic mercury into a particle or the precipitation of ionic mercury out of the liquor (Chethan et al., 2014).

In the absorption technique, ionic mercury is absorbed by activated carbon. The activated carbon is added to the scrubber liquor either directly into the scrubber liquor lines or injected into the flue gas upstream of the scrubber. The activated carbon is removed from the scrubber via the dewatering step.

A number of precipitation agents have been identified and these can be grouped into five categories: first, inorganic sulfides; second, organic sulfides; third, organic compounds containing nitrogen and sulfur; fourth, organic compounds containing oxygen and sulfur; and, fifth, low molecular weight sulfur-containing polymers (Keiser et al., 2014).

#### *Cross-media effects for wet scrubber additives*

Depending on the scrubber additive, the captured mercury exits the scrubber either in the liquid or solid phases.

#### **3.3.4 Selective mercury oxidation catalyst**

It is well known that SCR catalysts can oxidize elemental mercury emitted from coal-fired boilers in a gaseous state and particulate form (Laudal et al., 2002). However, the mercury oxidation rate on the SCR catalyst correlates to the SO<sub>2</sub> oxidation and conversion rate which forms SO<sub>3</sub>, which can cause air heater fouling, stack corrosion, and visible stack plumes.

A special type of SCR catalyst achieving high mercury oxidation and high NO<sub>x</sub> removal with simultaneous low SO<sub>2</sub>-to-SO<sub>3</sub> conversion (known as the selective mercury oxidation catalyst) has therefore been developed. The basis for this approach is to oxidize as much elemental mercury as possible to then allow the downstream APCS to remove the oxidized mercury (Favale et al., 2013).

A selective mercury oxidation SCR catalyst that increases the mercury oxidation rate while maintaining its original SCR capability enhances the mercury removal in a co-benefit technique (Bertole, C., 2013). In some existing plants in North America, SCR catalysts have already been replaced by high mercury oxidation SCR catalysts. It has been confirmed that partial replacement can also lower mercury concentration in the stack gas (Favale et al., 2013).

#### *Cross-media effects for selective mercury oxidation catalyst*

Use of a selective mercury oxidation catalyst possibly increases the mercury content of fly ashes and FGD gypsum. The used catalyst should either be regenerated or disposed of in an environmentally sound manner.

### **3.4 Activated carbon injection for dedicated mercury control**

Sorbents with or without chemical treatment may be used for injection in order to accomplish mercury removal. Injection of sorbents into the flue gas of coal-fired boilers for mercury control has been applied at boilers in Germany since the 1990s (Wirling, 2000) and has been implemented in the United States on over 100 full-scale systems (GAO, 2009; Amar et al., 2010). Since about 2005, activated carbon injection technology has been commercially applied in the United States (ICAC, 2010a, Amar et al., 2010). In addition, it has been demonstrated at a Russian power plant burning Russian coal (USEPA, 2014). Since 2007, in a number of states in the United States, such as Massachusetts, New Jersey and Connecticut, for many existing coal-fired boilers using bituminous or subbituminous coals, activated carbon injection has been routinely used in order to meet regulatory emission limit values (ELVs) in the range of

1.1–3.3 grams per Gigawatt-hr (representing 85–95 per cent control). Regulatory compliance with these ELVs has been shown through measurements with mercury continuous emissions monitoring (CEM) systems or sorbent trap methods (Massachusetts Department of Environmental Protection, 2015; with similar reports from the New Jersey and Connecticut state environmental departments). ACI requires a downstream PM control device.

Table 6 below shows the emission values of four coal-fired power plants with dedicated mercury abatement techniques in the United States.

**Table 6**

Emission levels of coal-fired power plants with activated carbon injection

<i>Name</i>	<i>Coal type</i>	<i>Emission level normalized (<math>\mu\text{g}/\text{Nm}^3</math>) (normalized to 6 % <math>\text{O}_2</math> content)</i>	<i>Averaging period</i>	<i>Boiler size (MWth)</i>	<i>Flue gas treatment technique</i>
Oak Grove, Boiler 1 USA	lignite	<0.80 in 2012	monthly/cont.	870	FF+SCR+FGD + ACI
PPI Montana Corette (USA)	sub-bituminous	0.9	Cont.	163	ACI with C-PAC + ESP
Brayton Point, Units 1,2,3 (combined), Massachusetts, USA	bituminous	0.2	Annual, 12-month rolling average	1350	ACI+ SCR+ESP+SDA
Bridgeport Harbor, Unit # 3, Connecticut, USA	bituminous	0.2-0.5	periodic	400	ACI + ESP

Note: C-PAC: Cement-friendly pulverized activated carbon; data are for year 2010 except for Oak Grove.

### 3.4.1 Injection of sorbent without chemical treatment

Some of the factors that affect the performance of any particular sorbent with regard to mercury capture include the physical and chemical properties of the sorbent, the injection rate of the sorbent, flue gas parameters (such as temperature, concentrations of halogen species, concentration of  $\text{SO}_3$ ) and existing APCS configuration (Pavlish et al., 2003; Srivastava et al., 2006; Martin, 2009).

Figure provides a summary of a number of tests conducted more than ten years ago with untreated activated carbon injection at four power plants (Pleasant Prairie, Gaston, Salem Harbour, Brayton Point). Mercury removal efficiency by injection of untreated activated carbon depends strongly on the rank of coal and the type of PM control used in the plant. The Pleasant Prairie power plant used low-sulfur, Powder River Basin (PRB) coal and was equipped with an ESPc. PRB coal is a low rank subbituminous coal which contains low chlorine and high calcium, making it difficult for the elemental mercury to be oxidized by chlorine in the flue gas. Activated carbon injection was not effective for mercury control for this plant with mercury emissions consisting predominantly of elemental mercury, as untreated activated carbon is not effective for capturing the unreactive elemental mercury. As a strong contrast, the Gaston power plant demonstrated that activated carbon injection was extremely effective for controlling mercury emissions from this plant that burned low-sulfur bituminous coal and was equipped with an ESPh followed by a small, specially designed FF called a compact hybrid particulate collector (COHPAC). The injection of untreated activated carbon took place at the outlet of the ESPh because the temperature at the inlet was too high. The COHPAC was used for removing the injected carbon. Application of a COHPAC as an effective means of mercury control was demonstrated in the Gaston power plant.

In some cases low mercury removal by untreated activated carbon is the result of a combination of lower levels of chlorine in subbituminous coal in the United States and the neutralization of halogen species by high levels of sodium and calcium in the subbituminous coal fly ash. As a result, there is little free chlorine in the flue gas stream for mercury oxidation. Mercury oxidation (with chlorination of the surface as the initial step) is necessary for the capture of elemental mercury by untreated activated carbon and, in general, the efficiency of mercury capture with untreated activated carbon increases with the amount of oxidized mercury in the flue gas (US DOE, 2005).

Thus, mercury capture with untreated activated carbon may be limited in plants firing low-rank coals, such as lignite and subbituminous.

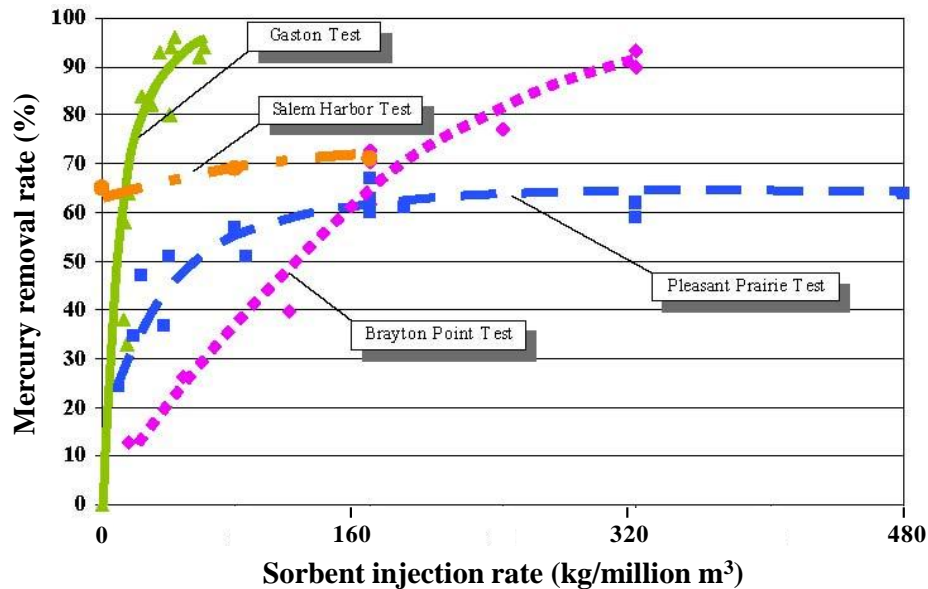

Figure 9. Testing of mercury removal efficiency as a function of untreated ACI rate

3.4.2 Injection of chemically treated sorbent

To overcome limitations described above and associated with the use of untreated activated carbon for mercury control in power plants, treated activated carbon sorbents have been developed (Nelson, 2004 and Nelson et al., 2004). The treatment most often used and that has been demonstrated as the most effective in enhancing the performance of activated carbon was bromination.

Relative to untreated activated carbon, brominated activated carbon:

- (a) Expands the usefulness of sorbent injection to situations where untreated activated carbon may not be effective;
- (b) In general, can be operated at lower injection rates, which leads to fewer plant impacts and a lower carbon content in the captured fly ash;
- (c) Results in better performance with low chlorine coals.

Improvement in the performance of mercury control was observed during full-scale field tests of chemically treated activated carbon injected upstream of the existing PM device (Feeley et al., 2008) and is shown in Figure . As may be seen in Figure , improved mercury capture efficiency was achieved using relatively low injection rates of treated activated carbon at power plants burning low-chlorine coals. The treated activated carbon achieved in excess of 90 per cent mercury capture at an injection rate of about 50 mg/m<sup>3</sup> (Feeley et al., 2008). Higher injection rates were required to achieve high mercury removal efficiency when untreated activated carbon was used, and in some cases, it was not possible to achieve 75 per cent capture.

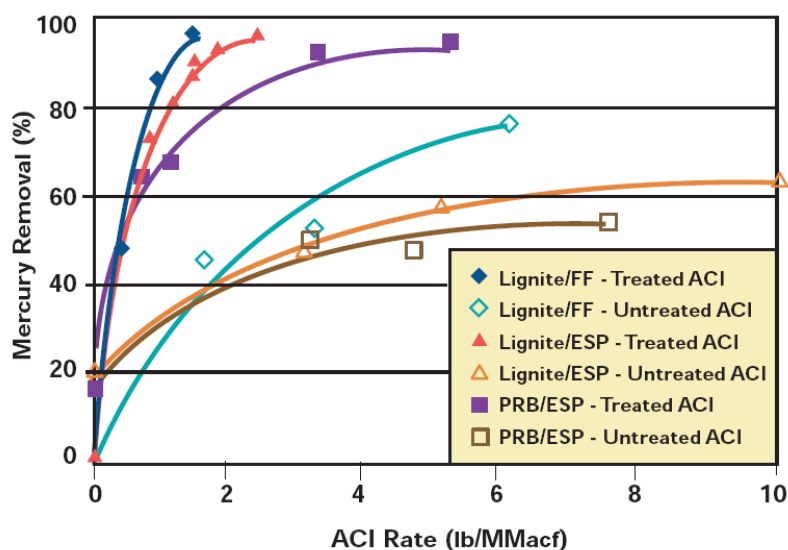

**Figure 10. Comparison of untreated activated carbon and treated activated carbon performance for mercury removal**

**3.4.3 Activated carbon injection applicability restrictions**

Despite the activated carbon injection method being commercially implemented in multiple and diverse applications, some issues remain, including the marketability of fly ash for concrete manufacturers and the effect of SO<sub>3</sub> on the performance of activated carbon injection systems.

A typical activated carbon injection system is located upstream of a PM control device, which leads to mixing of the sorbent and fly ash. While this is not a concern in cases where fly ash is not sold for concrete production, this mixing can negatively affect the use of fly ash in concrete production. Concrete quality is particularly sensitive to carbon content, and also affected by the surface area of the carbon present in the fly ash.

An effective method of eliminating fly ash contamination is to add an additional FF downstream of the existing ESP or to inject the activated carbon after the PM device and into a wet FGD, which may affect the quality of the gypsum produced by the FGD (Miller et al., 2014; Mimna et al., 2014). In addition, in some plants which burn low mercury coal and use FFs for PM control, the amount of treated activated carbon required for a mercury reduction greater than 85 per cent is as low as 8 mg/m<sup>3</sup>. In such cases, the presence of activated carbon in the fly ash may not affect the sale of fly ash for concrete.

Concrete-compatible carbon sorbents have been developed that allow some coal-fired power plants to continue marketing fly ash for concrete production (Nelson et al., 2006; Landreth et al., 2012). These are commercially used in the United States.

Tests have also been carried out on other non-carbon sorbents designed to preserve fly ash quality while still allowing sorbent injection rates capable of delivering up to about 85 per cent mercury removal (Kang et al., 2007). Likewise, techniques for the post-treatment of fly ash to remove UBC and activated carbon have been developed. These include thermal treatment of fly ash and electrostatic separation of carbon from fly ash.

Testing has shown that SO<sub>3</sub> in the flue gas, even at low concentrations, can interfere with the performance of activated carbon injection systems. It appears that SO<sub>3</sub> competes with mercury for adsorption sites on the sorbent surface, thereby limiting its performance. This phenomenon may be particularly relevant to activated carbon injection applications at plants firing high-sulfur coal. One possible solution to the SO<sub>3</sub> interference issue is the combined injection of mercury sorbents and alkaline materials. Some alkaline materials are being used as suggested in Feeley and Jones (2009) These include calcium hydroxide (Ca(OH)<sub>2</sub>), sodium bicarbonate (NaHCO<sub>3</sub>), and sodium sesquicarbonate (trona).

*Cross-media effects for activated carbon injection*

The use of non-concrete-compatible activated carbon injection methods can result in the loss of the use of fly ash in concrete, and therefore may increase the quantities of fly ash sent to landfill. Tests on two commercial activated carbons indicate that the mercury captured by activated carbon is sufficiently stable to provide permanent sequestration of mercury in activated carbon sorbents after disposal (Graydon et al., 2009; US EPA, 2006; US EPA, 2009a).

Activated carbon injection located upstream of a PM control device affects the quality of fly ash as a consequence of mixing of the activated carbon and the fly ash. There is the potential of secondary mercury release from fly ash when exposed to elevated temperatures during reuse of fly ash, for example, the use of fly ash for cement manufacture or brick-making (Pflughoeft-Haassett et al, 2007).

**3.5 Cost of mercury control technologies**

Mercury emission control can be accomplished as a co-benefit removal by the equipment already in place, which might have been installed for a different purpose. Defining the cost of mercury removal accomplished as a co-benefit is complex because cost apportionment needs to be considered between the costs of mercury control and those of controlling other pollutants such as PM, SO<sub>2</sub> or NO<sub>x</sub> (Sloss, 2008). Usually mercury reduction through co-benefit effects (the installation of technologies such as FGD and SCR which also reduce mercury emissions) can be regarded as minimal in cost or even cost-free. This is because high capital cost technologies like SCR and FGD are generally added for the purpose of NO<sub>x</sub> or SO<sub>x</sub> control, respectively, and would not be added solely for mercury control. Alternatively, mercury control may be accomplished by dedicated technology such as activated carbon injection at a much lower cost provided that there is an existing PM control device. Assigning costs for the latter is more straightforward.

There are three cost components resulting from the application of dedicated mercury emission control technology: capital cost, fixed operating and maintenance cost, and variable operating and maintenance cost. For activated carbon injection, the variable operating and maintenance cost is estimated to be small even though it is a major component of the total cost (EPA, 2005; Amar et al., 2010) because capital costs are relatively low. This depends on the application.



Sorbent requirements can vary significantly between different sites. The major components of the variable operating and maintenance costs are sorbent costs and disposal costs. There may also be lost revenue from fly ash sales due to the contamination of fly ash by activated carbon. To overcome this, so-called “concrete-friendly” activated carbons have been developed, along with technologies to separate activated carbon from fly ash.

### 3.5.1 Costs for co-benefit mercury control technologies

The actual capital costs of air pollution control at a particular facility are often proprietary and agreed to during direct negotiations between technology vendors and their clients. A substantial amount of cost information is publicly available, however, and this is presented below. Some general guidelines should be adhered to when evaluating these data:

- Capital costs for a new installation may vary depending on redundancy factors used for design and on locally prevailing financing options (e.g., capital charge rates);
- Capital costs for a retrofit installation may vary depending on the on-site conditions such as availability of space, and the so-called “retrofit difficulty factor”;
- Levelized cost of control equipment varies with the capacity factor of plant, with the levelized cost generally decreasing as the capacity factor increases (Celebi, 2014).

The costs of control technologies vary significantly when applied to different countries. Table 7 and 8 show the costs of co-benefit technology in China and United States. It can be seen that the capital cost of a wet FGD installed in a 600 MW unit may be 20 times lower in China than in the United States. It should be noted that, when considering nationwide or even region-wide deployment of BAT, a range of costs should be considered for any given BAT rather than an exact figure. In this context, the values in Table 7 and 8 should be considered to be indicative only, and reference should also be made to the other cost data (e.g., UK Department of Trade and Industry (2000); Sargent and Lundy (2007)).

The conventional APCDs are not dedicated to mercury emission control, however, and therefore the total costs of co-benefit mercury control technologies need to be apportioned to different air pollutants. A Chinese study (Ancora et al., 2015) used a pollutant equivalent apportionment method based on the health and environmental impact of each pollutant and distributed the total annual cost to mercury, PM<sub>10</sub>, SO<sub>2</sub> and NO<sub>x</sub> (see Table 99).

**Table 7**

Costs of air pollution control devices in power plants (CNY/kQ, 2010 Yuan), China (Ancora et al., 2015)

<i>APCD</i>	<i>Capacity (MW)</i>	<i>Capital cost (CNY/kW)</i>	<i>O&amp;M cost (CNY/kW/yr)</i>
ESP	<100	108±8	7±2
ESP	<300	100±7	6±2
ESP	>300	94±7	5±2
FF	<100	91±8	10±4
FF	<300	80±7	9±3
FF	>300	71±6	9±3
WFGD	<100	736±178	74±29
WFGD	<300	410±99	56±22
WFGD	>300	151±37	36±14
SCR	<100	123±29	43±18
SCR	<300	99±23	31±13
SCR	>300	75±18	20±8

Key: APCD – air pollution control device; CNY – yuan renminbi; O&M – operating and maintenance

**Table 8**

Capital cost of co-benefit technology in the United States (\$/kW, 2012 dollars) (US EPA, 2013)

<i>Technology</i>	<i>Unit size, MW</i>	<i>Coal type</i>	<i>Total capital cost (US\$/kW)</i>	<i>Total O&amp;M costs, fixed and variable (US\$/MWh)</i>
Wet FGD	500	Bituminous	531	11.52
SDA FGD	500	Sub-Bituminous	470	10.45
SCR	500	Bituminous	274	1.85
FF	500	Bituminous	195	1.02

**Table 9**

Costs of APCS combinations apportioned to different pollutants for a 600MW unit, China (million CNY, 2010 Yuan)(Ancora et al, 2015)

<i>APCS combination</i>	<i>Total annual costs</i>	<i>Costs apportioned to Hg removal</i>	<i>Costs apportioned to PM<sub>10</sub> removal</i>	<i>Costs apportioned to SO<sub>2</sub> removal</i>	<i>Costs apportioned to NO<sub>x</sub> removal</i>
ESP	8.324	0.479	7.845	-	-
FF	9.241	1.167	8.075	-	-
ESP+WFGD	39.871	1.613	11.571	26.687	-
SCR+ESP+WFGD	56.992	2.200	14.636	33.759	6.396
FF+WFGD	40.789	2.181	11.759	26.849	-
SCR+FF+WFGD	57.909	2.874	14.811	33.817	6.407

### 3.5.2 Costs for co-benefit enhancement techniques and ACI

The costs for activated carbon injection comprise of two components: first, capital costs for the sorbent storage and injection equipment; and, second, fixed and variable operating and maintenance costs (associated with the expendable sorbent). To assess the cost of mercury removal via the co-benefit route, a distinction must be drawn between the investment and operating and maintenance cost of the APCSs, such as FGD and SCR, which are well defined, and the cost of enhancing or optimizing the mercury removal in those APCSs.

In general, the cost of co-benefit enhancement techniques is difficult to assess since it is dependent on multiple variables such as coal origin and quality, the extent of refurbishment required for the existing PM controls (in the case of ESP), or site-specific operating regimes of wet FGD. As a result, relative costs were first arrived at for approaches discussed in this document; these approaches are shown in Table 10, which were, among other things, based on information presented in the process optimization guidance document (UNEP, 2010). The relative capital and incremental operating and maintenance costs shown in Table 10 should only be treated as trend indications, and should not be construed as universally applicable guidelines to the selection of cost-effective approaches to mercury emission control from coal-fired power plants or industrial boilers that might be located in different countries. Locally prevalent economic conditions (e.g., cost of supplies and materials, efficiency and cost of labour, transportation cost, etc.) should always be considered during the selection of a mercury control option, while acknowledging the fact that many markets for emission control equipment and engineering construction companies are also global (Pacyna et al., 2010).

**Table 10**

Relative cost of mercury removal for various methods

<i>Approach</i>	<i>Capital cost</i>	<i>O&amp;M cost</i>	<i>Comments</i>
Coal washing	Moderate	Low	Washing less expensive than chemical treatment.
Coal blending	Very low	Very low	May require adjustment and/or refurbishment of pulverizers
Hg oxidation additives	Very low	Low	Halogenated additives significantly increase Hg oxidation and capture
Re-emission control additives	Very low	Low	Potential for re-emission of Hg should be mitigated
Selective Hg-oxidation	Low	Low	Only referring to Hg-specific catalyst, may require coal

<i>Approach</i>	<i>Capital cost</i>	<i>O&amp;M cost</i>	<i>Comments</i>
SCR catalyst*			blending
Activated carbon injection (ACI)	Low	Low to Moderate	Preservation of ash quality an issue. Higher incremental costs for “concrete-friendly” sorbents

\* with downstream wet FGD

**Table 11**

Capital cost of ACI in United States (\$/kW, 2007 dollars)

<i>Technology</i>	<i>Unit size, MW</i>			
	<i>100</i>	<i>300</i>	<i>500</i>	<i>700</i>
ACI	3–8	2–6	2–5	2–5

Notes:

Data in table 11 from tables 5–16 in USEPA, 2010

Cost ranges are for modified pulverized activated carbon injection with FF or cold-side ESP

Case considered is for bituminous coal and other assumptions in EPA Base Case v.4.10

Relatively low sensitivity of capital cost of ACI to unit size, as shown in Table 11, may be interpreted as resulting in comparable cost effectiveness of mercury removal via activated carbon injection (cost of removing a unit mass of mercury) for small and large units (e.g., small industrial boiler vs. large utility boiler at a power plant). In-depth analysis of activated carbon injection costs for control of mercury emissions (USEPA, 2010), from which Table 11 was derived, gave capital costs in 2007 ranging from 2 to 8 \$/kW depending on configuration, activated carbon type (standard or modified), and unit size (from 100 to 700 MW). It should be noted that the cost values in Table 11 do not include the capital cost of FFs or ESPs. The cost of installing a new FF or baghouse is 55–70 \$/kW regardless of plant size. For the same range of variables, the study arrived at a fixed operating and maintenance cost varying from 0.03 to 0.1 \$/kW/year.

The actual cost of mercury control with activated carbon will also depend on the particulate control system used. Table 12 shows the operating costs for ESP and COHPAC (advanced hybrid particle collector) fabric filters. The estimates are for a 250 MW plant with an 80 per cent capacity for firing bituminous coal and assumed the cost of the COHPAC system would be around 50 \$/kW (\$12.5 million).

**Table 12**

Operating costs for activated carbon injection systems (on a 250 MW plant) followed by either ESP or FF for bituminous coals (IJC, 2005)

	<i>ESP</i>	<i>COHPAC</i>
Mercury removal, %	70	90
PAC injection rate, kg/Macm	160	48
PAC injection cost, \$	790 000	790 000
Activated carbon cost, \$	2 562 000	796 000

The sorbent costs depend upon the coal characteristics, type of existing APCs at the plant, and the level of mercury capture required. Jones and others (2007) listed the costs of carbons from several different suppliers and they ranged from 0.87 \$/kg to 2.11 \$/kg.

The type of activated carbon affects both the injection rate and the operating cost. The unit price of brominated activated carbon can be 30 per cent higher than that of the untreated activated carbon. The performance of brominated activated carbon, however, can be significantly better than that of untreated activated carbon for certain types of coal (Chang et al., 2008).

## 4 Emerging techniques

There are plenty of emerging techniques for mercury emission control in coal-fired power plants. Although they may still at the bench or pilot stage, some of the techniques have already shown promising mercury control effectiveness and low cost. The emerging techniques are either dedicated to mercury emission control or designed for multi-pollutant emission control. Information on some of these techniques is provided below.

### 4.1 Non-carbon sorbents

Metal oxides, such as  $\text{TiO}_2$ , are non-carbon sorbents for flue gas mercury. Laboratory and pilot-scale studies in the United States (Suriyawong et al., 2009) showed high mercury capture efficiency of up to 94 per cent using  $\text{TiO}_2$  with UV irradiation. Copper-based sorbents are also used to control mercury emissions in coal-fired flue gas.  $\text{CuO}_x$  impregnated on neutral  $\text{Al}_2\text{O}_3$  ( $\text{CuO}_x\text{-Al}_2\text{O}_3$ ) sorbents were found to enhance the catalytic oxidation of elemental mercury in the presence of HCl, and the mercury adsorption rate was over 75 per cent in the early stage of the mercury removal process (Du et al., 2015). Non-carbon sorbent can also be mixed with activated carbon to enhance the performance. A mixture of  $\text{CuO}_x\text{-Al}_2\text{O}_3$  and activated carbon can remove more than 90 per cent elemental mercury with a lower cost for industrial applications (Du et al., 2015).

### 4.2 Non-thermal plasma

The use of non-thermal plasma (NTP) offers a promising technology for elemental mercury oxidation. NTP is recognized as a potential process for the simultaneous removal of NO,  $\text{SO}_2$  and elemental mercury. Chemically active species such as O, OH,  $\text{HO}_2$  and  $\text{O}_3$ , formed from the pulsed corona discharge, induce the oxidation of  $\text{Hg}^0$ . HCl can promote the oxidation of mercury due to chlorine atoms produced in the plasma process (Ko et al., 2008). The rate of elemental mercury oxidation by the dielectric barrier discharges (DBD) system, averages at around 59 per cent (Jia et al., 2013). Another study showed that the NO,  $\text{SO}_2$  and elemental mercury oxidation rates by the pulsed corona discharge (PCD) system reached 40, 98 and 55 per cent respectively (Xu et al., 2009).

### 4.3 Cerium-treated activated coke

Activated coke is a regenerative sorbent for multi-pollutant (NO,  $\text{SO}_2$  and elemental mercury) control. Virgin activated coke can remove 30–40 per cent of elemental mercury, while, when loaded with 5 per cent  $\text{CeO}_2$ , the performance of activated coke can achieve a stable elemental mercury removal efficiency of over 60 per cent (Hua et al., 2010).

### 4.4 Sorbent polymer composite module

This technique uses a sorbent and polymer composite (SPC) which is mounted in modules and placed downstream of the existing APCS. The SPC media can adsorb both elemental and oxidized mercury. The modules are stackable and each module has a given mercury capture potential. The amount of mercury removal therefore depends on the number of modules used.

The SPC technique can be applied in combinations with other APCSs. The optimal mercury adsorption temperature of the SPC is 85 °C and where the flue gas temperature is higher, an evaporative cooler can be installed upstream of the SPC modules.

Series of SPC modules have the capability to reduce mercury emissions by 90 per cent or more. One feature of SPC technique is that its collected mercury is separated from coal combustion residues such as scrubber water, gypsum and fly ash.

At this time the SPC technique has been installed on approximately 1,000 MW of coal-fired power plants (ZMWG, 2015).

## 5 BAT and BEP for coal combustion

General principles for the choice of BAT for the point source categories listed in Annex D are described in the introductory chapter of this guidance document. Here we focus on the choice of mercury controls in the coal combustion sector.

### 5.1 Best available techniques

There are four main types of control measures for atmospheric emissions of mercury from coal-fired power plants and industrial boilers.

#### 5.1.1 Primary measures to reduce the mercury content of coal

The first type involves the removal of mercury prior to combustion. Coal washing, selection or blending are effective technologies for improving efficiency in the use of coal and for reducing the emission of air pollutants. The extent to which coal washing has been applied in coal-fired power plants and in industrial coal-fired boilers has been quite low, however, and the proportion of coal washing has grown slowly, because by itself it does not constitute BAT. Yet, when combined with other control measures described below, it can provide reasonable reductions in mercury emissions.

#### 5.1.2 Measures to reduce mercury emissions during combustion

The second type of control measures involves the removal of mercury during combustion. The use of a fluidized bed boiler plays an important role in mercury removal downstream. Particularly important are the much higher percentages of particulate mercury in flue gas from fluidized bed compared with pulverized coal firing. This high percentage of mercury present as particulates leads to high mercury removal efficiency of downstream FFs or ESPs. It should be noted, however, that the use of a fluidized bed boiler itself does not constitute BAT.

#### 5.1.3 Mercury removal by co-benefit of conventional APCSSs

The third type of control measures for mercury removal involves the use of APCSSs which are mainly used for the removal of PM (ESP, FF or a combination of both), SO<sub>2</sub> (dry or wet FGD), and NO<sub>x</sub> (SCR), but can result in substantial reductions in mercury emissions as a co-benefit. In some countries, the co-benefit removal of mercury is the first measure considered for the reduction of mercury emissions from coal-fired power plants or industrial boilers.

Emission levels and removal efficiencies achieved through the application of APCSSs were shown in section 3.2 above. This demonstrates that the combination of SCR, ESP and FGD, which is widely used in the coal-fired power plants in Europe, the United States, China and Japan, can accomplish mercury removal efficiencies of up to 95 per cent and a concentration of less than 1 µg/Nm<sup>3</sup> of mercury in the flue gas from plants burning hard coal.

The combination of SCR, FF and FGD can achieve mercury removal efficiencies of up to 99 per cent and a concentration of less than 0.5 µg/Nm<sup>3</sup> of mercury in the flue gas from plants burning lignite.

#### 5.1.4 Dedicated mercury control technologies

The fourth type of control measures involves dedicated technologies for the reduction of atmospheric mercury emissions, including activated carbon injection technology or the use of additives. Currently, activated carbon injection technology has been widely commercialized and adopted for coal-fired power plants in the United States and has successfully complied with regulatory emission limit values representing 85–95 per cent control over more than five years (Massachusetts Department of Environmental Protection, 2015). The operations of activated carbon injection technology in the United States show that the mercury concentration in flue gas after activated carbon injection and fabric filters may be lower than 1 µg/Nm<sup>3</sup>.

## 5.2 Best environmental practices

Effective pollution control management strategies, well-maintained facilities, well-trained operators, and constant attention to the process are all important factors in controlling and, where feasible, reducing the emissions of mercury from coal combustion. As such, these practices, applicable to existing and new sources, are considered to be BEP and should be performed in a manner which is consistent with the application of BAT.

### 5.2.1 Key process parameters

The first step in determining BEP for the coal combustion process is to identify the key process parameters (including mercury input control in coal and related monitoring), either from site-specific investigations or from testing undertaken on similar facilities elsewhere. Based on the investigations and testing, measures that enable control of key process parameters should be introduced into the management system.

### 5.2.2 Consideration of energy efficiency for whole plant

Energy efficiency of a coal-fired power plant is defined as the ratio between the output (net electricity, net heat, or both) from the plant and the amount of source energy (in coal) supplied to the plant over the same period. The

efficiency of the steam turbine (based on lower heating value of coal) in a new pulverized coal-fired plant varies from 39 to 47 per cent, depending on steam conditions (Eurelectric, 2003). Newly constructed plants designed for subcritical steam conditions operate at the lower end, whereas plants designed for supercritical and ultra-supercritical steam conditions operate at the higher end of this efficiency range. Circulating fluidized bed combustion (CFBC) boilers typically operate above 40 per cent efficiency. As recently as 2011, only about half of all new coal-fired power plants were designed for high efficiency low emission operation (IEA, 2012).

As plants age their efficiency decreases, requiring more coal to generate the same amount of output. For any given coal-fired power plant or industrial boiler, the amount of uncontrolled mercury emissions from the plant or the boiler is directly related to the amount of coal burned. It follows that, if the amount of coal burned could be reduced, then the overall mercury emissions from a given power plant or industrial boiler would also decrease. This reduction in the amount of coal burned could be accomplished by measures undertaken to improve the energy efficiency of an existing power plant or industrial boiler.

Energy-efficient design, equipment maintenance, and improved efficiency also provide for the reduction of all emitted pollutants from the same volume of coal used, including greenhouse gases such as CO<sub>2</sub>, in addition to a reduction of mercury emissions. Should the upgrading of a plant be implemented for business or economic reasons, it would result in more energy and less emissions being produced from the same volume of coal used (Sloss, 2009).

Examples of measures to improve energy efficiency in coal-fired power plants or coal-fired industrial boilers can include detailed measurements to identify thermal losses, fixing leakages in flue-gas ducts, upgrading air heaters, new blading for turbine, overhauling or upgrading of the condenser, new packing for the cooling tower, or improving the electrical efficiency of the plant.

High efficiency combustion is facilitated by establishing a monitoring regime of key operating parameters, such as carbon monoxide (CO), volumetric flow rate, temperature and oxygen content. Low CO is associated with higher combustion efficiency in terms of the burnout of the feeding coal. Combustion efficiency depends on several factors, including steam conditions, type of coal, local climate at location, age of plant, capacity, and operation mode (IPPC, 2013).

### **5.2.3 APCS maintenance and removal efficiency**

Beyond better energy efficiency, improving the efficiency of APCSs offers the opportunity to maximize the removal of mercury. The incremental amount of mercury removal is achieved as a result of operating APCS equipment originally designed to limit non-mercury emissions such as PM, SO<sub>2</sub>, or NO<sub>x</sub>, which is already in place at the power plant or an industrial boiler. Depending on the available APCS equipment, these approaches could include decreasing the parasitic power requirements of APCSs, modernization or upgrades of ESPs or FFs, alteration of SCR design and operation, or a combination of the above (Sloss, 2006).

### **5.2.4 Environmentally sound management of the plant**

To improve the prevention and control of mercury emissions, an environmental management system that clearly defines responsibilities at all levels is needed for a coal-fired power plant or a coal-fired industrial boiler. Some of the most commonly applicable measures are dedicated to the improved operation of the boiler, such as implementing appropriate inspection and maintenance cycles. Operating and maintenance practices have the potential to improve plant performance, including its efficiency and reliability, and also to decrease the overall operating and maintenance costs themselves. Deterioration of plant equipment is unavoidable; however, the rate at which this deterioration occurs depends greatly on the operating and maintenance practices. Some of the good operating and maintenance practices include for example, steam line maintenance, water treatment, and a reliable protocol for monitoring and reporting. In addition, process improvements may be necessary to reduce bottlenecks and delays.

Adequate resources should be allocated to implement and continue the application of BEP, and staff should be appropriately trained relevant to their duties. Independent third-party field-based and remote auditing protocols are also important to ensure that BEP are actually being followed.

### **5.2.5 Environmentally sound management of coal combustion residues**

Environmentally sound management of coal combustion residues (CCRs) is important to minimize the potential for increasing the risk of mercury re-emission and other potential problems.

Throughout the process of mercury emission control from coal-fired sources, mercury is removed from flue gas and transferred to CCRs, including boiler bottom ash, fly ash, and sludge from wet FGD. Sludge from wet FGD and other CCRs are either stored at the site or reused, including through further processing into gypsum wallboard. In the latter case, after FGD gypsum has been filtered out of the sludge, mercury may need to be extracted from the FGD wastewater effluent depending on the levels present. This may be accomplished via chemical treatment, ion exchange, or with membrane filtration. In the processes of gypsum wallboard production, other use of CCRs, including during storage of CCRs at the site, mercury contained within them may have the potential of being re-released.

In the process of gypsum wallboard production, a fraction of mercury may be re-released because the production processes often include high-temperature units. In one study, total mercury loss across the wallboard plant represented about 5 per cent of the incoming FGD gypsum mercury content (Marshall, 2005). Another study by Liu et al. (2013) indicated, however, that 12–55 per cent of total mercury in the FGD gypsum would be emitted during wallboard production and a third study found releases ranging from 2 to 66 per cent of the mercury in the incoming FGD gypsum (Sanderson et al, 2008). Given the potential variability in release rates, wallboard production using FGD gypsum is not regarded as BEP unless the mercury re-emissions are shown to be minimal or are captured during the wallboard production.

In the case of on-site storage of CCRs, there may be a potential for cross-media impacts (e.g., for leaching of mercury into groundwater). A multi-year study of leaching characteristics of CCRs concluded that any potential release of metals from CCRs to the environment is affected by leaching conditions (USEPA, 2006; USEPA, 2008; USEPA, 2009a).<sup>34</sup> Leaching conditions are affected by the pH and by the amount of water contact (ratio of liquid-to-solids). When evaluated over the pH range from 5.4 to 12.4 (plausible range for management of CCRs), the mercury leach results did not exceed existing standards for the concentration of mercury in well-water in the United States. In these same studies, some leach results for some other heavy metals, such as arsenic, were found to exceed existing standards for concentration in well-water in the United States. It should be noted that the data presented do not include any attempt to estimate the amount of constituent that may reach an aquifer or drinking water well. Groundwater transport and fate modelling, including the consideration of many additional factors – including how the fly ash is managed – would be needed to assess the potential risk. The storage of CCRs with impervious surfaces at the site can be considered as one aspect of environmentally sound management.

---

<sup>34</sup> The leach testing methods used in these studies have been developed into standard tests, known as the “LEAF” methods, by the USEPA. The methods are numbered 1313–1316, and can be found at: [http://epa.gov/wastes/hazard/testmethods/sw846/new\\_meth.htm](http://epa.gov/wastes/hazard/testmethods/sw846/new_meth.htm).

## 6 Mercury emissions monitoring

General and cross-cutting aspects of testing, monitoring and reporting are discussed in the introductory chapter of this document. The present section is limited to specific aspects of mercury emissions monitoring for coal-fired power plants and industrial boilers.

### 6.1 Continuous emissions monitoring

Mercury monitoring using continuous emissions monitoring (CEM) instruments is effective for coal combustion flue gas streams (Sarunac, 2007). For emission compliance purposes, CEM instruments are located in the stack and measure a gas stream of low particulate concentration.

For mercury process optimization purposes, CEM instruments are sometimes used to sample the particulate-laden gas stream before a particulate control device. A commonly used filter probe technology for this purpose is the inertial filter. It uses a technique of sample gas acceleration and relies on the inertial forces of the particulate and a sintered filter to separate the gas and particulates.

CEM monitoring of sample gas saturated with water by a wet scrubber is commonly practised although it requires more elaborate procedures. A special fixed filter probe is used to avoid blockage from the condensation of water and typically employs a frequent filter media cleaning cycle using compressed air. All applications of CEM monitoring use heated sample lines with careful regulation of sample gas temperature to avoid the condensation of water and the resulting absorption of oxidized mercury into this water.

A CEM instrument provides the coal combustion operator with real time mercury analysis which can be used in a feedback loop with the sorbent injection or coal additive feed equipment. This feature allows tight control over the concentration of mercury emissions, despite changes of mercury concentration in the fuel.

The CEM also provides the advantages of sensitivity to low concentrations of mercury, down to  $0.5 \mu\text{g}/\text{m}^3$ , speciated mercury measurements, and high repeatability of results when calibrated with a dynamic mercury spiking methodology.

### 6.2 Sorbent trap monitoring

Sorbent traps for mercury monitoring in coal combustion gas streams have been shown to provide accurate and replicable data, even at very low mercury emission concentrations (Sarunac, 2007). It is possible to monitor using one set of traps over a sampling period lasting several days in coal combustion plants.

### 6.3 Impinger sampling

The use of impinger methods for mercury monitoring in coal combustion plants has historically been the prominent method. Impinger methods are not appropriate for long sampling periods and in practice are limited to several hours in length (Sarunac, 2007).

Many impinger methods separately collect particulate, oxidized, and elemental mercury and are therefore useful in coal combustion plants for determining the mercury speciation.

The impinger methods use multiple impingers in series to allow a certain measure of quality control.

### 6.4 Mass balance

Mass balance measurements in coal combustion plants are not a direct monitoring method for mercury air emissions and it can be expected that the accuracy of air emissions calculated from mass balance will be low.

The data required to perform a mass balance measurement of mercury in coal combustion plants are readily available in some regions because the mercury content of solid and liquid waste streams from the plant is regulated. Waste streams include bottom ash, fly ash, scrubber wastewater, scrubber products such as gypsum, and scrubber waste solids. Mercury measurement of the coal burned is also regularly measured in certain regions and is necessary for the mass balance calculation.

Mass balance accuracy is heavily dependent on representative sampling of the coal and waste streams and of proper sample stabilization. Special procedures must be followed to avoid loss of mercury from collected samples. Greater accuracy of the mass balance results can be achieved with a greater number of samples collected and analysed. A significant variation in the mercury content of the coal may be expected, so frequent coal analysis is required for an accurate mercury input value. Periodic mercury air emissions monitoring must be practised to validate the mass balance calculations.

Considering the number of material streams which require monitoring and the frequency of sampling to achieve an accurate mass balance, it may be more difficult to use a mass balance method for the monitoring of mercury air emission in coal combustion plants than a direct flue gas monitoring method.



## **6.5 Predictive emissions monitoring systems (PEMS)**

Predictive emissions monitoring is a good screening tool for coal combustion plants but, owing to the wide mercury content variation of coal, it is not an accurate means of monitoring mercury air emissions.

The predictive monitoring systems are useful for estimating the mercury air emissions in preparation for sorbent trap or other monitoring activities. A good estimate of the air emission range will allow for a more efficient sorbent trap test.

## **6.6 Emission factors**

Emission factors are not an accurate means of monitoring mercury air emission for coal combustion gas streams. This is due to the variation of mercury content in coal and the wide variation in mercury capture within a coal combustion plant's emission control equipment. This latter point makes emission factors very difficult to accurately apply across the fleet of coal combustion plants.

## **6.7 Engineering estimates**

Engineering estimates are not an accurate method of monitoring mercury air emission for coal combustion plants.

## 7 References

- ACAP (2004). Assessment of mercury releases from the Russian Federation. Russian Federal Service for Environmental, Technological and Atomic Supervision, Danish Environment Protection Agency for Arctic Council, COWI, December 2004.
- Ake, Terrence; Sulfur Dioxide Control for Small Utility Boilers, Air and Waste Management Association, 2009.
- Amar, P, C. Senior and R. Afonso (2008). NESCAUM Report: Applicability and Feasibility of NO<sub>x</sub>, SO<sub>2</sub>, and PM Emissions Control Technologies for Industrial, Commercial, and Institutional (ICI) Boilers (<http://www.nescaum.org/activities/major-reports>).
- Amar, P, C. Senior, R. Afonso and J. Staudt (2010). NESCAUM Report “Technologies for Control and Measurement of Mercury Emissions from Coal-Fired Power Plants in the United States: A 2010 Status Report”.
- Ancora, M. P., L. Zhang, S.X. Wang, J. Schreifels and J.M Hao (2015). Economic Analysis of Atmospheric Mercury Emission Control for Coal-Fired Power Plants in China. *Journal of Environmental Sciences* vol. 27, issue 7, pp125–134..
- ASTM D388 (2012). Standard Classification of Coals by Rank.
- Babcock Power, Circulating Dry Scrubbers (CDS) Webinar Presentation, 2012 Mid-Atlantic Regional Air Management Association, 19 July 2012.
- Bertole, C., 2013; SCR Catalyst Management and Improvement to Achieve and Maintain Mercury Oxidation Levels, May 2013 (2013).
- Bojkowska, I., Sokolowska, G., 2001. Mercury in mineral raw materials exploited in Poland as potential sources of environmental pollution (In Polish), *Biuletyn PIG*, No. 5, p. 53.
- Brown, T. D., D.N. Smith, R.A. Hargis, Jr., W.J. O’Dowd. (1999). 1999 Critical Review: Mercury Measurement and Its Control: What We Know, Have Learned, and Need to Further Investigate, *Journal of the Air & Waste Management Association*, vol., 49, pp. 1–97.
- Buschmann, J., Lindau, L., Vosteen, B.W. (2006). The KNXTM Coal Additive Technology –a Simple Solution for Mercury Emissions Control, *Power Gen USA*, December 2005.
- Celebi, M. (2014). "Coal Plant Retirements and Market Impacts", The Brattle Group, presented to Wartsila Flexible Power Symposium, Vail, CO, February 2014.
- Chang, R., Dombrowski, K., Senior, C. (2008). Near and Long-Term Options for Controlling Mercury Emissions from Power Plants, *The MEGA Symposium*, Baltimore, MD, 2008.
- Chathen, A., Blythe, G., Richardson, M., Dene, C., (2014). Scrubber Additives for Mercury Re-Emission Control, *The MEGA Symposium*, Baltimore, MD, August 2014.
- Chu, P. (2004). Effects of SCRs on Mercury, *Mercury Experts Conference*, Glasgow, Scotland, May 2004.
- Clack, H.L. (2006). Mass Transfer within ESPs: Trace Gas Adsorption by Sorbent-covered Plate Electrodes, *Journal of the Air & Waste Management Association*, vol. 56, pp. 759–766.
- Clack, H.L. (2009). Mercury Capture within Coal-Fired Power Plant Electrostatic Precipitators: Model Evaluation, *Environ. Sci. Technol.*, vol. 43, pp. 1460–1466.
- CRIEPI and FEPC (2012). Data evaluated by CRIEPI (Central Research Institute of Electric Power Industry) in 2012, based on the data provided by FEPC (the Federation of Electric Power Companies of Japan).
- DeVito, M.S., Rosenhoover, W.A. (1999). Hg Flue Gas Measurements from Coal-fired Utilities Equipped with Wet Scrubbers, 92nd Annual Meeting of the Air & Waste Management Association, St. Louis, MO, June 1999.
- Deye, C.S., Layman C.M. (2008). A Review of Electrostatic Precipitator Upgrades and SO<sub>2</sub> Reduction at the Tennessee Valley Authority Johnsonville Fossil Plant, *The MEGA Symposium*, Baltimore, MD, 2008.
- Dombrowski, K., S. McDowell, et al. (2008). The balance-of-plant impacts of calcium bromide injection as a mercury oxidation technology in power plants. *A&WMA MEGA Symposium*. Baltimore, MD.
- Duan, Y. F. , Zhuo, Y. Q., Wang, Y. J. , Zhang, L. , Yang, L. G., Zhao, C. S., 2010. Mercury Emission and Removal of a 135MW CFB Utility Boiler. *Proceedings of the 20th International Conference on Fluidized Bed Combustion* 2010, 189–194.
- Eurelectric, 2003, Efficiency in Electricity Generation, EURELECTRIC "Preservation of Resources" Working Group, in collaboration with VGB, July 2003.

- European IPPC Bureau (EIPPCB) (2013). Best Available Techniques (BAT) Reference Document for the Large Combustion Plants—first draft (not adopted), June 2013  
[http://eippcb.jrc.ec.europa.eu/reference/BREF/LCP\\_D1\\_June2013\\_online.pdf](http://eippcb.jrc.ec.europa.eu/reference/BREF/LCP_D1_June2013_online.pdf).
- Favale, A., Nakamoto, T, Kato, Y., and Nagai Y. (2013), Mercury Mitigation Strategy through the Co-Benefit Of Mercury Oxidation With SCR Catalyst, Power Engineering, January 2013.
- Feeley, T., III, Brickett, L.A., O’Palko, B.A., Jones, A.P. (2008). DOE/NETL’s Mercury Control Technology R&D Program – Taking Technology from Concept to Commercial Reality, presented at the MEGA Symposium, Baltimore, MD, 2008.
- Feeley, T. J. and Jones, A. P. (2009). An Update on DOE/NETL’s Mercury Control Technology Field Testing Program. U.S. Department of Energy, available at <https://www.netl.doe.gov/File%20Library/NewsRoom/Updated-netl-Hg-program-white-paper-FINAL-July2008.pdf>.
- Feng, W., Kwon, S., Feng, X., Borguet, E., M.ASCE, R. D. V. (2006). Sulfur Impregnation on Activated Carbon Fibers through H<sub>2</sub>S Oxidation for Vapor Phase Mercury Removal. *Journal of Environmental Engineering*, 292–300.
- Finkelman B. Personal communication: USGS, 2003 // United Nations Environment Programme (UNEP). Toolkit for Identification and Quantification of Mercury Releases. Geneva, Switzerland: UNEP, 2005.
- Finkelman B. Personal communication: USGS, 2004 // United Nations Environment Programme (UNEP). Toolkit for Identification and Quantification of Mercury Releases. Geneva, Switzerland: UNEP, 2005.
- Galbreath, K.C. and Zygarlicke, C.J. (2000). Mercury Transformations in Coal Combustion Flue Gas, *Fuel Process. Technol.*, 65–66, 289.
- GAO (2009). Preliminary Observations on the Effectiveness and Costs of Mercury Control Technologies at Coal-fired Power Plants, United States Government Accountability Office, GAO-09-860T, Washington, DC, 2009.
- Ghorishi, S. B., Keeney, R. M., Serre, S. D., Gullett, B. K., Jozewicz, W. S. (2002). Development of a Cl-Impregnated Activated Carbon for Entrained-Flow Capture of Elemental Mercury, *Environ. Sci. Technol.*, vol. 36, pp. 4454.
- Graydon J. W., Zhang, X. Z., Kirk, D. W., Jia, C.Q. (2009). Sorption and stability of mercury on activated carbon for emission control. *Journal of hazardous materials*, 168(2-3): 978–82
- ICAC (2010). Enhancing Mercury Control on Coal-fired Boilers with SCR, Oxidation Catalyst, and FGD, Institute of Clean Air Companies. Available at: [www.icac.com](http://www.icac.com).
- ICAC (2010a). Commercial Bookings List, June 2010. Available at: [www.icac.com/files/members/Commercial\\_Hg\\_Bookings\\_060410.pdf](http://www.icac.com/files/members/Commercial_Hg_Bookings_060410.pdf).
- ICAC (2012). Sorbent Injection Technology for Control of Mercury Emissions from Coal-Fired Boilers. Available at: [www.icac.com](http://www.icac.com).
- IEA, 2012, High-Efficiency, Low-Emissions Coal-Fired Power Generation-Technology Roadmap, International Energy Agency, Paris, France, 2012.
- IJC, International Joint Commission (2005) Consultation on emissions from coal-fired electrical utilities. Background report from the International Joint Commission and the Commission for Environmental Cooperation, International Air Quality Advisory Board, Montreal, QC, Canada, vp (Apr 2005).
- Institution of Chemical Engineers, Controlling Industrial Emissions-Practical Experience SS143 (Symposium). 1997.
- Ito S., Yokoyama T., Asakura K. (2006). Emission of mercury and other trace elements from coal-fired power plants in Japan, *Science of the Total Environment*, vol.368, pp. 397–402.
- Jia B J, Chen Y, Feng Q Z, Liu L Y (2013) Research progress of plasma technology in treating NO, SO<sub>2</sub> and Hg<sub>0</sub> from flue gas. *Applied Mechanics and Materials*, 295-298: 1293–1298.
- Jones A P, Hoffman JW, Smith D N, Feeley T J, Murphy J T (2007) DOE/NETL’s Phase II mercury control technology field testing program: preliminary economic analysis of activated carbon injection. *Environmental Science and Technology*; 41 (4); 1365–1371.
- Kang, S.; Edberg, C.; Rebula, E.; Noceti, P. (2007). Demonstration of Mer-Cure™ Technology for Enhanced Mercury Control, DOE/NETL Mercury Control Technology Conference, Pittsburgh, PA, 11–13 December 2007.
- Keiser, B., Glesmann, S., Taff, B., Senior, C., Ghorishi, B., Miller, J., Mimna, R., Byrne, H., Improving Capture of Mercury Efficiency in WFGDs by Reducing Mercury Reemissions, ICAC, June 2014
- Kilgroe, J. D., C. B. Sedman, R. K. Srivastava, J. V. Ryan, C. Lee and S. A. Thorneloe (2001). Control of mercury emissions from coal-fired electric utility boilers: interim report including errata dated 3-21-02. Carbon, U.S.

- Environmental Protection Agency, Office of Research and Development, National Risk Management Research Laboratory, Air Pollution Prevention and Control Division, 5: 33.
- Ko K B, Byun Y, Cho M, Hamilton I P, Shin D N, Koh D J, and Kim K T (2008) Pulsed Corona Discharge for Oxidation of Gaseous Elemental Mercury. Chemistry Faculty Publications. Paper 2.  
[http://scholars.wlu.ca/chem\\_faculty/2](http://scholars.wlu.ca/chem_faculty/2).
- Landreth, R. and Royer, D., (2012). Extended use of concrete-friendly C-PAC sorbent at PPL Montana Corette Station, MEGA Symposium, Baltimore, MD, 2012.
- Laudal, D.L.; Thompson, J.S.; Pavlish, J.H.; Brickett, L.; Chu, P.; Srivastava, R.K.; Lee, C.W.; Kilgroe, J.D. (2002) *Evaluation of Mercury Speciation at Power Plants Using SCR and SCR NOx Control Technologies*, 3<sup>rd</sup> International Air Quality Conference, Arlington, Virginia, September 9–12, 2002.
- Lawless, P. (1996). Particle Charging Bounds, Symmetry Relations, and Analytic Charging Rate Model for the Continuum Regime, *J. Aerosol Sci.*, vol. 27, no. 2, pp. 191–215, 1996.
- Leaner, J.J., Dabrowski, J.M., Mason, R.P., Resane, T., Richardson, M., Ginster, M., Gericke, G., Petersen, C.R., Masekoameng, E., Ashton, P.J., Murray, K., (2009). Mercury Emissions from Point Sources in South Africa, In: Pirrone, N., and Mason, R. (eds.) *Mercury Fate and Transport in the Global Atmosphere*, Springer.
- Leitfaden zur energetischen Verwertung von Abfällen in Zement- Kalk und Kraftwerken in Nordrhein-Westfalen, 2. Auflage Ministerium für Umwelt und Naturschutz, Landwirtschaft und Verbraucherschutz des Landes Nordrhein-Westfalen, Düsseldorf, September 2005.
- Liu X.L., Wang S.X., Zhang L., Wu Y., Duan L., Hao J.M. (2013) Speciation of mercury in FGD gypsum and mercury emission during the wallboard production in China. *Fuel*, vol. 111, pp. 621–627.
- Lu, Y., Rostam-Abadi, M., Chang, R., Richardson, C., Paradis J. (2007). Characteristics of Fly Ashes from Full-Scale Coal-Fired Power Plants and Their Relationship to Mercury Adsorption, *Energy & Fuels*, vol. 21, pp. 2112–2120.
- Marshall, J., Blythe, G.M., and Richardson, M. (2005). Fate of Mercury in Synthetic Gypsum Used for Wallboard Production. Topical report, Task 1 Wallboard Plant Test Results, DE-TC26-04NT42080, April 2005.
- Martin, C. (2009). Activated Carbon Injection for Mercury Control from Coal-Fired Boilers, An Overview, Presented at the Energy Efficiency and Air Pollutant Control Conference, Wroclaw, Poland, September 2009.
- Massachusetts Department of Environmental Protection (2015). Annual Compliance Reports for SO<sub>2</sub>, NO<sub>x</sub>, and Mercury Emissions from Coal-Fired Power Plants (also, similar annual compliance reports from power plants in States of New Jersey and Connecticut).
- McTigue, N. E., Cornwell, D. A., Graf, K., & Brown, R. (2014). Occurrence and consequences of increased bromide in drinking water sources. *JOURNAL AWWA*, 106, 11.
- Miller, C., Feeley, III, T., Aljoe W., Lani, B., Schroeder, K., Kairies, C., McNemar, A., Jones A., Murphy, J. (2006). Mercury Capture and Fate Using Wet FGD at Coal-Fired Power Plants, DOE/NETL Mercury and Wet FGD R&D, Pittsburgh, PA, August 2006.
- Nakayama, Y., Nakamura, S., Takeuchi, Y., Itoh, M, Okino, S., Honjo, S. (2006). MHI High Efficiency System; Proven technology for multi pollutant removal, The MEGA Symposium, Baltimore, MD, 2006.
- Napolitano, S. (1998). "Analyzing Electric Power Generation under the CAAA", US EPA, March 1998.
- Nelson P. F. (2007) Atmospheric emissions of mercury from Australian point sources. *Atmospheric Environment*, vol. 41, pp. 1717–1724.
- Nelson, S., Landreth, R., Zhou, Q., Miller, J. (2004). Accumulated Power-Plant Mercury-Removal Experience with Brominated PAC Injection, Joint EPRI DOE EPA Combined Utility Air Pollution Control Symposium, The MEGA Symposium, Washington, DC, 2004.
- Nelson, S.; Landreth, R.; Liu, X.; Tang, Z.; Miller, J.; Brickett, L. (2006). Brominated Sorbents for Small Cold-Side ESPs, Hot-Side ESPs, and Fly Ash Use in Concrete, DOE/NETL Mercury Control Technology Conference, Pittsburgh, PA, December 11–13, 2006.
- Niksa, S., Fujiwara, N. (2004). The Impact of Wet FGD Scrubbing On Hg Emissions From Coal-Fired Power Stations, The MEGA Symposium, Washington, DC, 2004.
- Nolan, P., Downs, W., Bailey, R., Vecchi, S. (2003). Use of Sulfide Containing Liquors for Removing Mercury from Flue Gases, US Patent 6,503,470, 7 January 2003.

- Pacyna, J., Sundseth, K., Pacyna, E.G., Jozewicz, W., Munthe, J., Belhaj, M., Astrom, S. (2010). An Assessment of Costs and Benefits Associated with Mercury Emission Reductions from Major Anthropogenic Sources, *Journal of the Air & Waste Management*, vol. 60, pp. 302–315, 2010.
- Peters, H. James (2010) Regenerative Activated Coke Technology with No Water Consumption, RMEL Spring Conference, Santa Fe NM, 17 March 2010 (<http://www.hamonusa.com/sites/default/files/Regenerative%20Activated%20Coke%20Technology%20with%20No%20Water%20Consumption.pdf>).
- Pirrone N, Munthe J, Barregård L, Ehrlich H C, Petersen G, Fernandez R, Hansen J C, Grandjean P, Horvat M, Steinnes E, Ahrens R, Pacyna J M, Borowiak A, Boffetta P., Wichmann-Fiebig M. EU ambient air pollution by mercury (Hg) - position paper. Italy: Office for Official Publications of the European Communities, 2001.
- Redinger, K.E., Evans, A., Bailey, R., Nolan, P. (1997). Mercury Emissions Control in FGD Systems, EPRI/DOE/EPA Combined Air Pollutant Control System, Washington, DC, 1997.
- Richardson, S. D., Plewa, M. J., Wagner, E. D., Schoeny, R., & DeMarini, D. M. (2007). Occurrence, genotoxicity, and carcinogenicity of regulated and emerging disinfection by-products in drinking water: a review and roadmap for research. *Mutation Research/Reviews in Mutation Research*, 636(1), 178–242.
- Rini, M.J., Vosteen, B.W. (2008). Full-scale Test Results From a 600 MW PRB-fired Unit Using Alstom's KNX™ Technology for Mercury Emissions Control, The MEGA Symposium 2008, Baltimore, MD, 2008.
- Rini, M.J., Vosteen, B.W. (2009). Full-Scale Test Results from a 600 MW PRB-fired Unit Using Alstom's KNX™ Technology for Mercury Control, MEC-6 Conference, Ljubljana, Slovenia, April 2009.
- Romanov, A., Sloss, L. and Jozewicz, W. (2012). Mercury emissions from the coal-fired energy generation sector of the Russian Federation. *Energy & Fuels*, vol. 26, pp. 4647–4654.
- Rupesh, K. (2013). Fuels and its Combustion in Boiler, Steag, 2013. Available at: <http://www.eecpowerindia.com/codlibrary/ckeditor/ckfinder/userfiles/files/Session%202%20%20module%20-%20Fuels%20and%20its%20Combustion%20in%20Boiler.pdf>.
- Sargent & Lundy (2007). Flue Gas Desulfurization Technology Evaluation (Dry Lime vs. Wet Limestone FGD), Project Number 11311-001 (2007).
- EPRI (2006). Status of Mercury Control Technologies: Activated Carbon Injection and Boiler Chemical Additives, Technical Report of EPRI (2006).
- Sarunac, Nenad, Evaluation and Comparison of US and EU Reference Methods for Measurement of Mercury, Heavy Metals, PM2.5 and PM10 Emission From Fossil-Fired Power Plants, Lehigh University, February 2007.
- Satyamurty, M. (2007). Coal Beneficiation Technology – 2007 Initiatives, Policies and Practices, presented at Workshop on Coal Beneficiation and Utilization of Rejects: Initiatives, Policies and Practice, Ranchi, India, 22–24 August 2007.
- Senior, C.L. (2000). Behavior of Mercury in Air Pollution Control Devices on Coal-fired Utility Boilers, Power Production in the 21st Century Conference, Snowbird, UT, USA, 2000.
- Senior, C. (2004). Modelling Mercury Behavior in Combustion Systems: Status and Future Prospects, In Proceedings of the Mercury Experts Conference MEC-1, Glasgow, Scotland, May 2004.
- Senior, C., Fry, A., Cauch, B. (2008). Modeling Mercury Behavior in Coal-Fired Boilers with Halogen Addition, The MEGA Symposium, Baltimore, MD, August 2008.
- Senior, C., Johnson, S. (2008). Impact of Carbon-in-Ash on Mercury Removal across Particulate Control Devices in Coal-Fired Power Plants, *Energy & Fuels*, vol. 19, pp. 859–863, 2005.
- Serre, S., Lee CW, Chu, P., Hastings T. (2008). Evaluation of the Impact of Chlorine on Mercury Oxidation in a Pilot-Scale Coal Combustor – The Effect of Coal Blending, The MEGA Symposium, Baltimore, MD, August 2008.
- Singer, J.G. (1991). *Combustion Fossil Power*, 1991.
- Sloss, L. (2008). *Economics of Mercury Control*, Clean Coal Centre, ISBN: 978-92-9029-453-5, January 2008.
- Sloss, L. (2009). *Implications of emission legislation for existing coal-fired plants*, Clean Coal Centre, ISBN: 978-92-90290464-1, February 2009.
- Sloss, L. (2015). *The emerging market for mercury control*, IEA, CCC, February 2015.
- Srinivasan, N. and Dene. C. (2013). Bromine Related Corrosion Issues, July 2013. Available at: <http://aepevents.com/files/presentations/2013-general-session-bromine-additon-for-mercury-capturesrinivasan-and-dene-epri-1378922295.pdf>.

- Srivastava, R., Martin, B., Princiotta, F, Staudt, J. (2006). Control of Mercury Emissions from Coal-Fired Electric Utility Boilers, *Environ. Sci. Technol.*, vol. 40, pp. 1385–1392, 2006.
- Srivastava, R.K., Jozewicz, W. (2001). Flue Gas Desulfurization: The State of the Art, *Journal of the Air & Waste Management Association*, vol.51, no.12, pp.1676–1688, 2001.
- Tewalt, S.J., Belkin, H.E., SanFilipo, J.R., Merrill, M.D., Palmer, C.A., Warwick, P.D., Karlsen, A.W., Finkelman, R.B., and Park, A.J., comp., 2010, *Chemical analyses in the World Coal Quality Inventory, version 1: U.S. Geological Survey Open-File Report 2010-1196*, <http://pubs.usgs.gov/of/2010/1196/>.
- Timpe, R.C.; Mann, M.D.; Pavlish, J.H. (2001). Organic Sulfur and HAP Removal from Coal Using Hydrothermal Treatment, *Fuel Process. Technol.*, vol. 73, no.2, pp.127–141, 2001.
- Toole-O’Neil, B., Tewalt, S.J., Finkelman, R.B., Akers. R. (1999). Mercury Concentration in Coal-Unraveling the Puzzle, *Fuel*, vol. 78, pp. 47–54, 1999.
- UK Department of Trade and Industry (2000), *Flue Gas Desulphurization (FGD) Technologies, Technology Status Report No.12*.
- UNEP (2008). *The Global Atmospheric Mercury Assessment: Sources, Emissions and Transport*. United Nations Environmental Programme, Chemicals Branch, DTIE, Geneva, Switzerland, December, 2008.
- UNEP (2010). *Process Optimization Guidance Document*, United Nations Environmental Programme, Chemicals Branch, Geneva, Switzerland, January 2011.
- UNEP (2011). *Reducing mercury emissions from coal combustion in the energy sector*. United Nations Environmental Programme, Chemicals Branch, Geneva, Switzerland, February 2011. Available at: [http://www.unep.org/chemicalsandwaste/Portals/9/Mercury/Documents/coal/FINAL%20Chinese\\_Coal%20Report%20-%202011%20March%202011.pdf](http://www.unep.org/chemicalsandwaste/Portals/9/Mercury/Documents/coal/FINAL%20Chinese_Coal%20Report%20-%202011%20March%202011.pdf).
- UNEP (2013a). *Global mercury assessment 2013: sources, emissions, releases, and environmental transport*. United Nations Environmental Programme, Chemicals Branch, Geneva. Available at: <http://www.unep.org/PDF/PressReleases/GlobalMercuryAssessment2013.pdf>.
- UNEP (2013b). *Reducing mercury emissions from coal combustion in the energy sector of the Russian Federation*. United Nations Environmental Programme, Chemicals Branch, Geneva. Available at: <http://www.unep.org/chemicalsandwaste/Portals/9/Mercury/Documents/coal/Report%20Demo-Toliatti%20FINAL%20Report%2027%20Nov%202013.pdf>.
- US DOE (2005). Feeley, J. III, Brickett, L.A, O’Palko A., Murphy J.T., *Field Testing of Mercury Control Technologies for Coal-Fired Power Plants*, Mercury R&D Review Meeting, December 2005.
- USEPA (1997). *Mercury Study Report to Congress, Volume I*, Office of Air Quality Planning and Standards and Office of Research and Development, Research Triangle Park, NC, EPA-452/R-97-004b, December 1997.
- USEPA (2001). *Database of information collected in the Electric Utility Steam Generating Unit Mercury Emissions Information Collection Effort*, OMB Control No. 2060–0396, Office of Air Quality Planning and Standards. Research Triangle Park, NC, April 2001. Available at: <http://www.epa.gov/ttn/atw/combust/utiltox/utoxpg.html>.
- USEPA (2002). *Control of Mercury Emissions from Coal-Fired Electric Utility Boilers: Interim Report Including Errata Dated 3-31-02*, Air Pollution Prevention and Control Division, National Risk Management Research Laboratory, Office of Research and Development, U.S. Environmental Protection Agency, Research Triangle Park, NC, EPA-600/R-01-109, April 2002.
- USEPA (2005). *Multipollutant Emission Control Technology Options for Coal-fired Power Plants*, Air Pollution Prevention and Control Division, National Risk Management Research Laboratory, Office of Research and Development, U.S. Environmental Protection Agency, Research Triangle Park, NC, EPA-600/R-05-034, March 2005.
- USEPA (2006). *Characterization of Mercury-Enriched Coal Combustion Residues from Electric Utilities Using Enhanced Sorbents for Mercury Control*, Air Pollution Prevention and Control Division, National Risk Management Research Laboratory, Office of Research and Development, U.S. Environmental Protection Agency, Research Triangle Park, NC, EPA-600/R-06-008, February 2006.
- USEPA (2008). *Characterization of Coal Combustion Residues from Electric Utilities Using Wet Scrubbers for Multi-Pollutant Control*, Air Pollution Prevention and Control Division, National Risk Management Research Laboratory, Office of Research and Development, U.S. Environmental Protection Agency, Research Triangle Park, NC, EPA-600/R-08-077, July 2008.
- USEPA (2009). *CUECost Workbook Development, Documentation*, Air Pollution Prevention and Control Division, National Risk Management Research Laboratory, Office of Research and Development, U.S. Environmental



Protection Agency, Research Triangle Park, NC, EPA-600/R-09-131, September 2009.

<http://nepis.epa.gov/Adobe/PDF/P1005ODM.pdf>.

USEPA (2009a). Characterization of Coal Combustion Residues from Electric Utilities-Leaching and Characterization Data, Air Pollution Prevention and Control Division, National Risk Management Research Laboratory, Office of Research and Development, U.S. Environmental Protection Agency, Research Triangle Park, NC, EPA-600/R-09-151, December 2009.

USEPA (2010). Documentation for EPA Base Case v.4.10 Using the Integrated Planning Model, EPA 430R10010.

USEPA (2013). Documentation for EPA Base Case v.5.13 Using the Integrated Planning Model EPA# 450R13002. <http://www.epa.gov/airmarkets/programs/ipm/psmodel.html>.

USGS (2014). Collaborative Studies for Mercury Characterization in Coal and Coal Combustion Products, Republic of South Africa, U.S. Geological Survey, Eastern Energy Resources Science Center, Reston, VA 20192, USA, January 2014.

Vassileva, S.V.; Eskenazy, G.M.; Vassileva, C.G. (2000). Contents, modes of occurrence and origin of chlorine and bromine in coal. *Fuel*, vol. 79, pp 903–921.

Vosteen, B.W., Beyer, J. et al. (2002). Process for Removing Mercury from Flue Gases, Patent Application DE 102 33 173, July 2002.

Vosteen, B.W., Beyer, J., Bonkhofer, Th.-G., Pohontsch, A., Wieland, A. (2003). Hg-Rückhaltung im reingasseitigen SCR-Katalysatorbett hinter der Rauchgaswäsche einer Sonderabfallverbrennungsanlage, *VGB PowerTech* 4/2003, 76-91. April 2003.

Vosteen, B. W., Beyer, J., Bonkhofer, Th.-G., Kanefke, R., Ulrich, R. (2003b). Mercury-Related Chemistry in Waste Incineration and Thermal Process Flue Gases, Poster, Air Quality Conference VI, Arlington VA, September 2003.

Vosteen, B. W., Kanefke, R. (2003c). Bromgestützte Quecksilberabscheidung aus den Abgasen von Verbrennungsanlagen, Studie im Auftrag des Landesumweltamts Nordrhein-Westfalen, Cologne, Germany, December 2003, available at: [http://vosteen-consulting.de/sites/Vosteen-Consulting/de\\_1958.asp](http://vosteen-consulting.de/sites/Vosteen-Consulting/de_1958.asp).

Vosteen, B.W., Lindau, L. (2006). Bromine Based Mercury Abatement-Promising Results from Further Full Scale Testing, MEC-3 Conference, Katowice, Poland, June 2006.

Vosteen, B.W.; Kanefke, R.; Koeser, H. (2006b). Bromine-enhanced Mercury Abatement from Combustion Flue Gases – Recent Industrial Applications and Laboratory Research, *VGB PowerTech* 3/2006, 70-75. March 2006.

Vosteen, B.W. (2010). Chinese Coals Need Bromine for Co-Benefit Mercury Capture, paper # C2-8 in Proceedings of 13th Electric Utilities Environmental Conference (EUEC), Phoenix, AZ, February 1-3, 2010. Wang Y., Duan Y., Yang L., Jiang Y., Wu C., Wang Q., Yang X. (2008). Comparison of Mercury Removal Characteristic between Fabric Filter and Electrostatic Precipitators of Coal-fired Power Plants, *J Fuel Chem Technol*, vol. 36, no. 1, pp. 23–29, 2008.

Wang, S., Zhang, L., Wu, Y., Ancora, M., Zhao, Y., Hao, J. (2010). Synergistic Mercury Removal by Conventional Pollutant Control Strategies for Coal-fired Power Plants in China, *Journal of the Air & Waste Management Association*, vol. 60, no.6, pp. 722–730.

Wang, S. X., Zhang, L., Li, G. H., Wu, Y., Hao, J. M., Pirrone, N., Sprovieri, F., Ancora, M. P. (2010) Mercury emission and speciation of coal-fired power plants in China. *Atmospheric Chemistry and Physics*, 10(3): 1183–1192.

WCA (2014). World Coal Association. Available at <http://www.worldcoal.org/coal/what-is-coal/>

Xu F, Luo Z, Cao W, Wang P, Wei B, Gao X, Fang M, Cen K (2009) Simultaneous oxidation of NO, SO<sub>2</sub> and Hg<sup>0</sup> from flue gas by pulsed corona discharge, *Journal of Environmental Sciences*, 21: 328~332.

Zhang, L., Wang, S. X., Meng, Y., Hao, J.M. (2012). Influence of Mercury and Chlorine Content of Coal on Mercury Emissions from Coal-Fired Power Plants in China. *Environ. Sci. Technol.*, 46 (11), pp. 6385–6392.

Zhang, L., Wang, S. X., Wang, F. Y., Yang, H., Wu, Q. R., Hao, J. M. (2013). Mercury transformation and removal in three coal-fired power plants with selective catalytic reduction systems. The 11th International Conference on Mercury as a Global Pollutant, Edinburgh, Scotland, UK, 2013.

Zhang, L., Wang, S.X., Wang, L., Wu, Y., Duan, L., Wu, Q.R., Wang, F. Y., Yang, M., Yang, H., Hao, J.M, Liu, X. (2015). Updated emission inventories for speciated atmospheric mercury from anthropogenic sources in China. *Environ Sci Technol.*, 49(5):3185-94. doi: 10.1021/es504840m.

Zhang, L. (2015). Mechanism of mercury transformation and synergistic removal from coal combustion. Postdoctoral Research Report, Beijing, China, 2015.

Zhuo, Y. (2007). Hg Emission from Six Coal-fired Power Plants in China and Its Implications, Mercury Emission from Coal, The 4th International Experts' Workshop MEC-4, Tokyo, Japan, 13 –15 June 2007.

ZMWG (2015) ZMWG Comments on Guidance on BAT/BEP for Coal-fired power plants and Coal-fired industrial boilers 1 August 2015; [http://mercuryconvention.org/Portals/11/documents/BAT-BEP%20draft%20guidance/Submissions/ZMWG\\_3.pdf](http://mercuryconvention.org/Portals/11/documents/BAT-BEP%20draft%20guidance/Submissions/ZMWG_3.pdf)

Zykov, A.M., Kolchin, K.I., Tumanovsky, A.G., Jozewicz, W. (2004). Joint Russian-American Project to Enhance Performance of Electrostatic Precipitators Used at Power Plants in the Newly Independent States, The MEGA Symposium, Washington, DC, 2004.



## Annex V

### **Smelting and roasting processes used in the production of non-ferrous metals (lead, zinc, copper and industrial gold as specified in Annex D to the Convention).**

#### **Non-ferrous metal smelting subgroup (copper, gold, lead and zinc)**

##### **BAT/BEP Guidance and Case Studies**

###### Summary

The main aim of the smelting process is to convert metal concentrates from their native state into pure metals; hence, smelting is a form of extractive metallurgy. Metals commonly exist in nature as oxides, sulfides or carbonates and the smelting process requires a chemical reaction in the presence of a reducing agent to liberate the metal. Mercury exists in trace amounts in nearly all metallurgical raw materials, and the thermal process can release this mercury to the atmosphere.

Metal production in general, and non-ferrous metal production in particular, is a large source of anthropogenic mercury emissions and estimated to account for some 10 per cent of global emissions. It is recognized that this estimate is subject to considerable uncertainty, and that site-specific data will be required to manage mercury at the local plant level.

The present chapter gives guidance on the control options for mercury from the non-ferrous metal sector (specifically for copper, zinc, lead and industrial gold, as listed in the Convention). It aims to provide parties to the Minamata Convention with guidance on identifying best available techniques (BAT) and best environmental practices (BEP), to enable them to meet their obligations under the Convention.

The guidance refers only to emissions from smelting and roasting processes used in the production of the above-mentioned non-ferrous metals. Processes other than smelting and roasting, such as hydrometallurgical processes, may also lead to emissions of mercury but they are not listed in Annex D of the Convention. Accordingly, these other processes are not addressed in this guidance.

The secondary smelting of metals from the non-ferrous sector usually results in negligible amounts of mercury emissions, because these metal recycling processes use scrap metal and drosses as feed. An exception may be seen in the secondary smelting of electronic waste but the techniques used to reduce emissions from secondary smelting are not likely to be substantially different from those used for primary smelting.

The chapter presents the processes required in the production of the metals covered in the guidance (copper, zinc, lead and industrial gold). It covers control technologies, including both technologies designed specifically for the control of mercury emissions, and also control technologies for other pollutants which may have co-benefits in reducing emissions of mercury. Emerging technologies are described, and guidance on BAT and BEP is provided. Information on monitoring specific to the non-ferrous metal sector is also provided.

## Contents

1	Introduction .....	68
2	Process descriptions .....	69
2.1	Process steps in lead production.....	69
2.1.1	Concentrate pretreatment .....	69
2.1.2	Smelting .....	69
2.1.3	Refining.....	70
2.1.4	Sulfuric acid plant .....	70
2.2	Process steps in zinc production.....	72
2.2.1	Blending, roasting and dust recovery .....	72
2.2.2	Gas cleaning.....	72
2.2.3	Sulfuric acid plant .....	73
2.2.4	Leaching.....	74
2.3	Process steps in copper production .....	74
2.3.1	Concentrate drying .....	74
2.3.2	Roasting .....	74
2.3.3	Smelting .....	74
2.3.4	Converting.....	75
2.3.5	Refining and casting.....	75
2.3.6	Slag cleaning .....	75
2.3.7	Sulfuric acid plant .....	75
2.4	Process steps in gold production .....	76
2.4.1	Roasting .....	76
2.4.2	Leaching.....	77
2.4.3	Stripping and regeneration .....	77
2.4.4	Refining.....	77
2.4.5	Furnace.....	77
3	Emission control techniques.....	79
3.1	Boliden Norzink process .....	79
3.1.1	Description.....	79
3.1.2	Applicability.....	80
3.1.3	Performance .....	81
3.1.4	Cross-media impacts .....	81
3.1.5	Costs of installation and operation .....	81
3.2	Selenium filter.....	81
3.2.1	Description.....	81
3.2.2	Applicability.....	82
3.2.3	Performance level .....	82
3.2.4	Costs of installation and operation .....	82
3.2.5	Cross-media impacts .....	83
3.3	Activated carbon .....	83

3.3.1	Description .....	83
3.3.2	Applicability.....	83
3.3.3	Performance level .....	83
3.3.4	Costs of installation and operation .....	83
3.3.5	Co-benefits .....	84
3.3.6	Cross media impacts .....	84
3.4	DOWA filter process (lead(II) sulfide covered pumice filter) .....	84
3.5	Jerritt process .....	84
3.5.1	Description.....	84
3.5.2	Applicability.....	85
3.5.3	Performance .....	85
3.5.4	Cross-media impacts .....	85
3.5.5	Costs of installation and operation .....	85
3.6	Co-benefits of common air pollution abatement technologies and acid plants in mercury control.....	86
3.6.1	Pollution abatement technologies.....	86
3.6.2	Combined gas cleaning and acid plants .....	87
4	Emerging and other processes .....	89
4.1	Selenium scrubber.....	89
4.2	Removal by reaction with sulfuric acid.....	89
4.2.1	Description .....	89
5	Best available techniques and best environmental practices .....	90
5.1	BAT overview.....	90
5.1.1	Some other considerations in the choice of mercury control in smelting and roasting in the non-ferrous metals sector.....	92
5.2	Best environmental practices .....	95
5.2.1	Environmental management systems .....	95
5.2.2	Blending feedstocks to control mercury emissions .....	95
5.2.3	Atmospheric mercury emissions .....	95
5.2.4	Particulate matter control .....	96
5.2.5	Environmentally sound management and disposal of air pollution control wastes .....	96
6	Monitoring of mercury in smelting and refining processes used in the production of non-ferrous metals .....	97
6.1	Direct measurement methods .....	97
6.1.1	Impinger sampling .....	97
6.1.2	Sorbent traps and sorbent trap monitoring systems.....	97
6.1.3	Continuous emissions monitoring systems .....	97
6.2	Indirect measurement methods.....	98
6.2.1	Mass balance .....	98
6.2.2	Predictive emission monitoring systems .....	98
6.2.3	Emission factors .....	98
7	References.....	99

## 1 Introduction

Mercury exists as a trace element in nearly all metallurgical raw materials and hence thermal processing and other smelting operations have the potential to release mercury to the atmosphere. The main aim of the smelting process is to convert metals from their native state in ores to pure metals and hence smelting is a form of extractive metallurgy. Metals commonly exist in nature as oxides, sulfides, or carbonates and the smelting process requires a chemical reaction in the presence of a reducing agent to liberate the metal.

The 2013 UNEP Report on the Global Mercury Assessment (AMAP/UNEP 2013) presents an emissions inventory for 2010, which, while based on, and similar in total to the 2005 inventory which was presented in a 2008 UNEP report (AMAP/UNEP 2008), contains a number of significant differences in several of the key sectors. Data in both these inventories illustrate that metal production in general, and non-ferrous metal production in particular, is a large anthropogenic source of mercury emissions and estimated to account for around 10 per cent of global emission. It is recognized that this estimate is subject to considerable uncertainty, and that site-specific data will be required to manage mercury at the local plant level.

This guidance document addresses the control options for mercury from the non-ferrous metal sector (specifically for copper, zinc, lead and industrial gold as listed in the Convention). It aims to provide parties to the Minamata Convention with guidance on identifying best available techniques (BAT) and best environmental practices (BEP) to enable them to meet their obligations under the Convention.

The guidance refers only to emissions from smelting and roasting processes used in the production of the above-mentioned non-ferrous metals. Processes other than smelting and roasting, such as hydrometallurgical processes, may also lead to emissions of mercury but they are not included in the Convention as listed in Annex D. Therefore, these other processes are not addressed in this guidance.

Secondary metals smelting produces negligible amounts of mercury emissions because these are, in fact, metal recycling processes that use scrap metal and drosses as feed. The only case where there may be small amounts of mercury released is during the recycling of zinc batteries that contain trace amounts of the element. Given the treaty requirements on products (controlled under Article 4, with permitted mercury content of button zinc silver oxide batteries set out in Annex A), the mercury content of batteries is also expected to decrease significantly.

This is supported by available data on mercury emissions from secondary smelters. For example, the United States Environmental Protection Agency required testing for mercury emissions from several secondary lead smelters in the United States in 2010 and established that in about 70 per cent of cases, the emissions were below the detection limit.

In some cases, secondary smelting of electronic material may produce significant mercury emissions. In such cases, however, activated carbon is usually used to reduce emissions and hence secondary smelting is not separately addressed in this guidance.

## 2 Process descriptions

The configuration of smelting and roasting operations depends on site conditions and specific characteristics of the ores or concentrates being processed, and multiple steps are often involved. In this section, general and brief descriptions of the relevant smelting and roasting processes for the lead, zinc, copper and industrial gold sectors are given.

The first stage in the processing of lead, zinc and copper ores is the production of concentrates. The concentrates are then often initially processed using a high temperature thermal process such as roasting, sintering or smelting. Because of the high temperature, mercury will be volatilized and thus be present in the exhaust gas.

In the exhaust gas, mercury will be adsorbed on particulate matter or present as soluble mercury compounds (e.g., mercury(II) chloride), and will also be present as elemental mercury. Oxidized species of mercury can normally be removed by using scrubbers, and wet electrostatic precipitators (ESPs). Particulate-bound oxidized mercury can be removed by baghouses. Elemental mercury, however, passes all such standard gas cleaning equipment. Therefore a second mercury removal stage may be needed to reduce the mercury to acceptable concentrations if it is present in the ore. Options are presented in section 3.

The reason elemental mercury cannot be effectively removed from an ambient temperature gas stream by scrubbing with water alone is its low solubility in water. One possibility is to adsorb mercury on sorbents like activated carbon. Another possibility is to oxidize mercury in some suitable manner, so that it can then be collected in solution or in the form of a solid compound.

If sulfidic raw materials are processed, the gas will contain sulfur dioxide, which is normally used to produce sulfuric acid. To produce sulfuric acid that meets commercial standards, low mercury content of the acid is required and will depend on the acid's ultimate use.

Techniques to reduce mercury emissions from smelting and roasting in the non-ferrous sector may also result in the production of mercury-containing materials. An example is calomel (mercury(I) chloride), produced in the Boliden-Norzink process (see section 3.1). This guidance does not address the management of these materials but under Article 11 of the Convention they should be stored or disposed of in an environmentally sound manner as waste.

Mercury may also be present in the wastewater produced by these processes and will require similar storage or management. Wastewater from the different sections of the plants is usually treated to remove harmful elements, such as heavy metals, residual oils or trace chemical reagents. Mercury is often precipitated as a very poorly soluble mercury sulfide and removed by decantation and filtration. The final sludge from the wastewater treatment plant is stored appropriately as waste. The sludge containing mercury should be managed in a manner consistent with other relevant articles of the Convention in an environmentally sound manner.

### 2.1 Process steps in lead production

The primary lead production process consists of three main stages: concentrate pretreatment; sintering or smelting; and refining. A schematic representation of the process is presented in Figure 1. Mercury is liberated mainly during the sintering and smelting processes and must be captured to minimize its emissions from the final stack.

#### 2.1.1 Concentrate pretreatment

In the concentrate pretreatment stage, various lead concentrates are blended to form a homogenous feed to the smelting process. Concentrate blending provides a more consistent metal content in the feedstock and reduces surges of impurities that could cause process or environmental upsets, or product quality issues. During blending, other raw materials may be added, such as fluxes or particulate matter recovered downstream from pollution control devices. Depending on process requirements, the blended lead concentrates may be dried to reduce moisture content. Some mercury emissions may be released during drying, either as gaseous mercury or as particulate matter.

#### 2.1.2 Smelting

Two main processes exist for smelting lead concentrates. The traditional process consists of first sintering the blended lead concentrates to remove sulfur and produce lead oxide. The lead oxide sinter product is then fed to a blast furnace where, using coke, it is reduced to lead bullion.

The second, more recently developed process, is the direct smelting of lead concentrates (also known as flash smelting). In direct smelting, the oxidation and reduction of the lead occurs within a single furnace. Heat released by the oxidation of sulfur in the concentrate drives the subsequent reduction reaction to produce lead bullion by the use of coal. Compared to the sinter-blast furnace smelting process, direct smelting uses less energy and generates lower levels of air emissions due to better sealing and capture of off-gas.

The off-gas from the sintering or direct smelting process contains particulate matter, sulfur dioxide, mercury and other impurities. The off-gas must be sent for gas cleaning prior to sulfuric acid production.

### **2.1.3 Refining**

The lead bullion is refined through several stages of pyrometallurgical treatment to remove other metals and impurities. During the drossing stage, lead bullion is cooled in a kettle until a dross forms on the surface. The dross, containing lead oxide and other metals, is skimmed off and treated elsewhere to recover the metals. The lead bullion is further refined by adding various reagents at different stages to remove specific metal impurities. The final pure lead can be cast into specific shapes or mixed with other metals to create alloys. Alternatively, lead refining can be carried out using an electro-refining technique, producing pure lead cathodes. It is not expected that significant emissions of mercury would occur during refining.

### **2.1.4 Sulfuric acid plant**

Smelter, or sintering plant off-gas, is treated to remove particulate matter and most metals, including mercury, using gas cleaning devices such as scrubbers and ESPs. If the gas still contains significant mercury, it then undergoes a mercury removal stage which removes the element as a waste. The management of mercury-containing materials, including storage, disposal and trade, should be consistent with other relevant articles of the Convention.

Following mercury removal, the gas contains a high concentration of sulfur dioxide, which is usually converted into sulfuric acid in an acid plant. Any remaining mercury will be contained in the acid. Commercial grades, however, typically specify a mercury concentration of less than 1 ppm in the acid, so effective mercury removal is required prior to the acid plant. The emissions from the final stack are expected to contain trace concentrations of mercury.

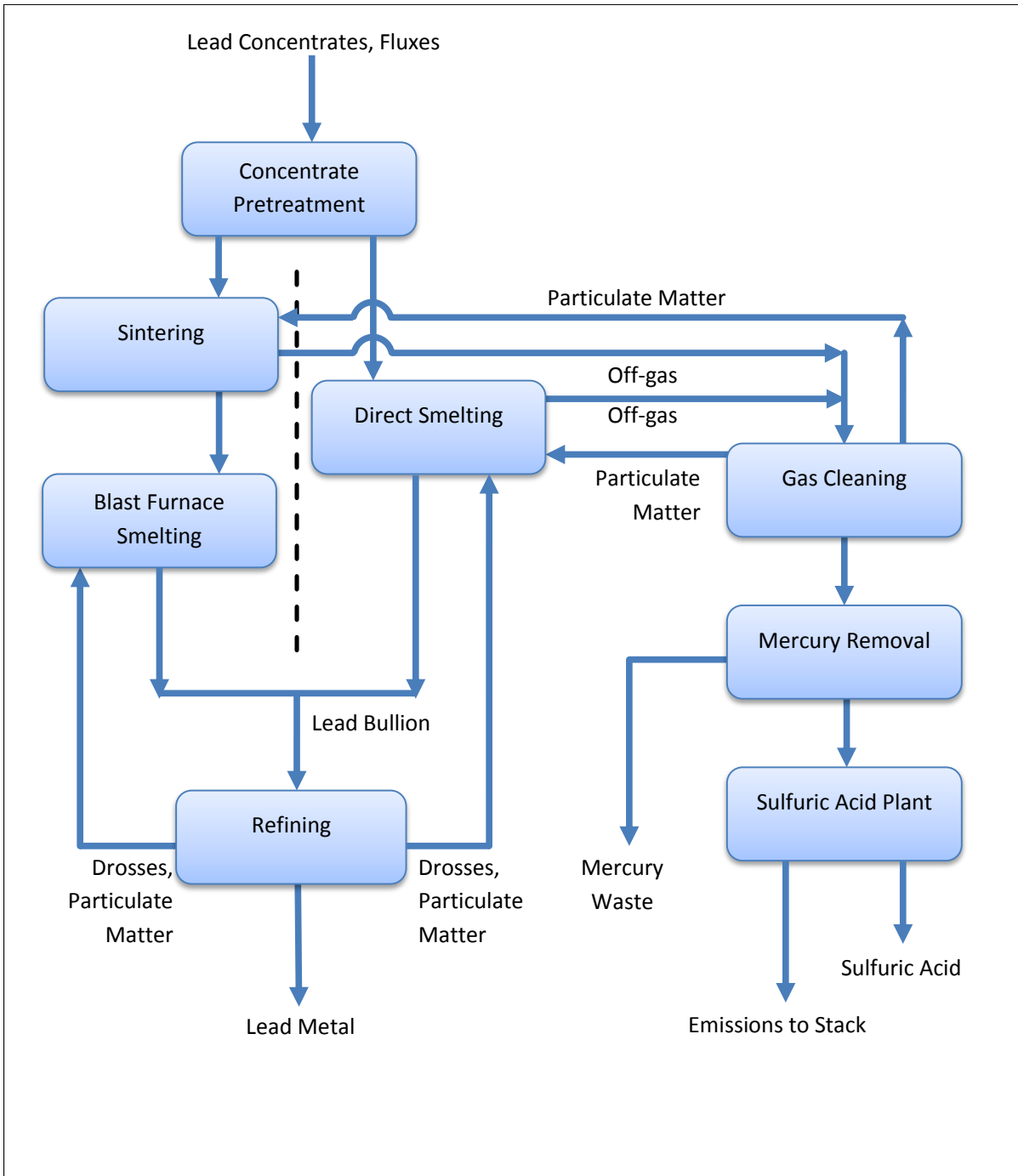

Figure 1: Processes in primary lead production

## **2.2 Process steps in zinc production**

The primary zinc production process consists of five main stages: concentrate blending; roasting or sintering and smelting; leaching and purification; electro-winning; and melting and alloying. A schematic representation of the process is presented in Figure 2. Mercury is liberated mainly during the roasting process and must be captured to minimize mercury emissions from the final stack.

### **2.2.1 Blending, roasting and dust recovery**

A schematic representation of the process steps in zinc production is presented in Figure 2. For commercial and logistical reasons, each zinc refinery will purchase zinc concentrates from several different mines. The mercury content from an individual mine can vary between 1 and 200 ppm but may range as high as 1,000 ppm. The key to smooth, environmentally managed and efficient operations is to ensure that all impurities, including mercury, are fed into the zinc process at a controlled rate. Blending is a well-established feed preparation process to mix concentrates of different quality. This prevents unexpected surges of impurities that can cause process or environmental upsets or lead to product quality problems.

Zinc concentrates are roasted by injection into a fluidized bed furnace at 950 °C where sulfides are transformed (roasted) into oxides and SO<sub>2</sub> gas. To avoid diffuse emissions, the furnace is operated under negative pressure. Virtually all mercury compounds present in the concentrates will vaporize in this furnace. Dust, also called particulate matter, is recovered from the gas stream. This dust goes to the leaching section, along with the zinc oxides from roasting. The gas flows to the gas cleaning stage.

Alternatively, in the Imperial Smelting process, zinc concentrates or bulk concentrates containing zinc and lead are first sintered, then smelted in an Imperial Smelting Furnace (ISF) (Morgan 1968).

### **2.2.2 Gas cleaning**

In the wet gas cleaning, the last traces of dust are removed using particulate matter abatement devices, such as scrubbers and ESPs. Wastewater from this gas cleaning contains mercury and other heavy metals and is treated in a wastewater treatment plant or is injected into the roasting furnace to maximize mercury collection via the dedicated mercury removal process. Different types of mercury removal processes exist and are described below. These specific mercury removal units reduce mercury concentrations to low levels. The output of this mercury removal process is a mercury concentrate. Some 50–90 per cent of the total mercury input ends up in this concentrate.



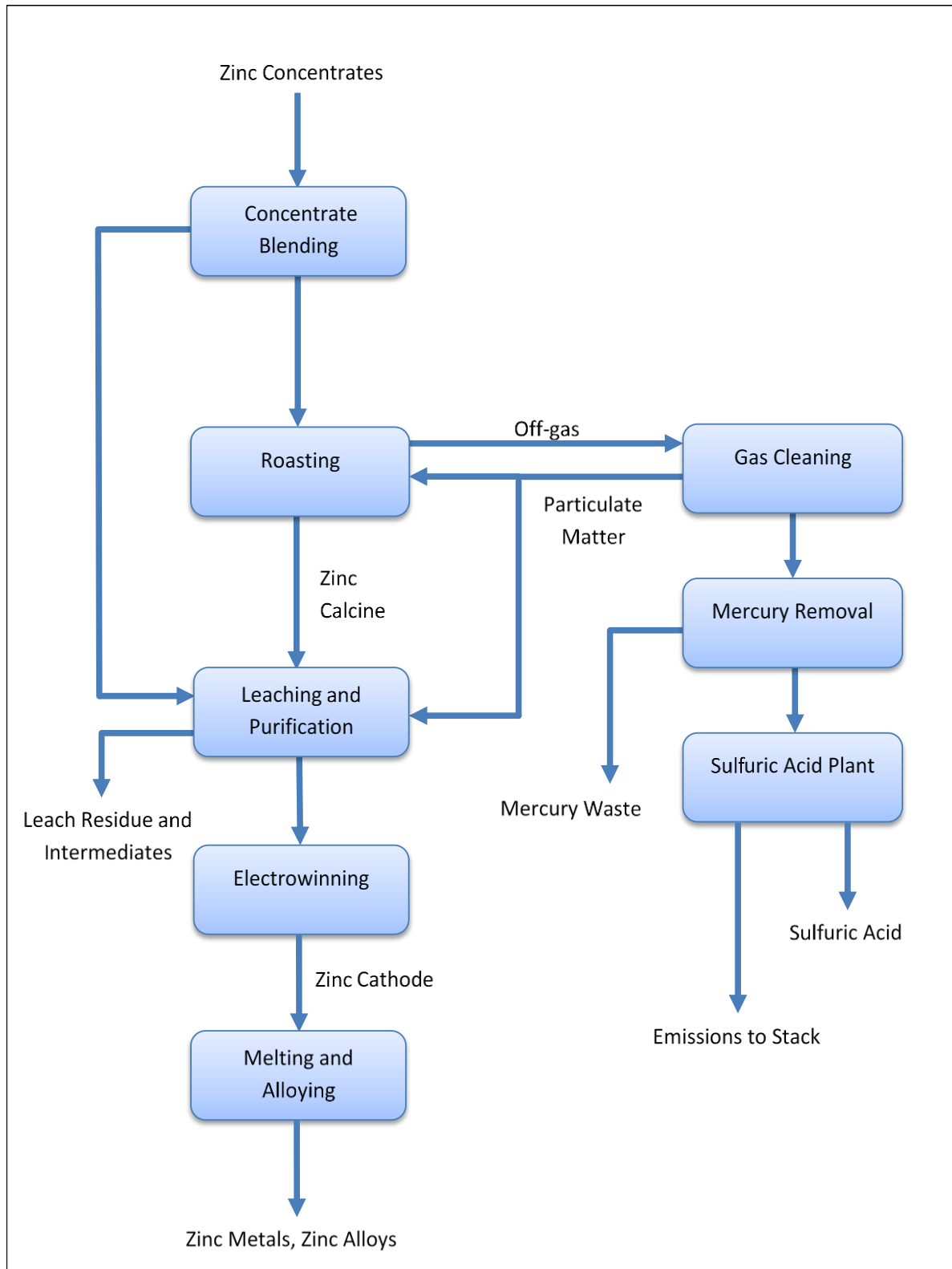

**Figure2: Processes in primary zinc production**

### 2.2.3 Sulfuric acid plant

After mercury removal, the  $\text{SO}_2$  from the gas is transformed into sulfuric acid. Approximately 90 per cent of the residual mercury in the gas stream will be trapped in the acid. To comply with commercial grades of sulfuric acid, mercury concentration in the acid should be less than 1 ppm. Less than 2 per cent of the total mercury input ends up in the sulfuric acid. The mercury emission from the stack where controls are in place is typically less than 0.1 ppm or less than  $100 \mu\text{g}/\text{Nm}^3$  and represents less than 0.25 per cent of the mercury input.

### 2.2.4 Leaching

In the leaching step, the oxidized zinc concentrate (known as “zinc calcine”), is dissolved in acid. The solution is purified by cementation on zinc metal dust (powder), containing no mercury and sent to the electrolysis plant to recover zinc metal. Other metals – e.g., copper, cadmium, lead, silver, cobalt and nickel – are recovered in separate fractions and further refined in other plants. A final leach residue, containing mainly iron in the form of jarosite, goethite or hematite, lead sulfate and silicates, will require management consistent with relevant articles of the Convention. Often the leach residue, which may contain some mercury, is recycled to a lead smelting process.

In the leaching process, there may also be a direct feed of unroasted mineral concentrates which do contain mercury. The input of unroasted concentrates in the leaching process is typically about 10 per cent of the total concentrate input but can increase to as much as 50 per cent when direct leaching is applied. Mercury from these unroasted concentrates ends up in the leach residue as a nearly insoluble mercury sulfide. Since mercury is not dissolved, there is no emission to air in the leaching process. Depending on the amount of unroasted concentrate present in this process step, some 5–50 per cent of the mercury input will end up in this leach residue.

## 2.3 Process steps in copper production

Primary copper can be produced by pyrometallurgical or hydrometallurgical processes. Approximately 20–25 per cent of primary copper is produced by hydrometallurgical technologies such as leaching of oxide type ores. The remainder of primary copper production uses the pyrometallurgical process. Since the hydrometallurgical process does not involve roasting or smelting, these processes are not covered by Annex D of the Minamata Convention and are, therefore, beyond the scope of this guidance document.

The copper ores that require processing through the pyrometallurgical process are sulfidic. When the pyrometallurgical process is used, any mercury present in the concentrate will be liberated primarily during concentrate smelting and matte converting into the process gas. Depending on the temperature of the dryers used, mercury may also be emitted during the drying process for facilities which use a concentrate dryer.

A schematic representation of various parallel pyrometallurgical processes in copper production is presented in Figure 3:

- Roasting, smelting and converting
- Smelting and converting
- Direct to copper smelting

### 2.3.1 Concentrate drying

The pyrometallurgical process starts with the blending of concentrates and fluxes to produce a stable and homogeneous feed, especially when processing concentrates with varying concentrations of copper or impurities. For flash smelting vessels, the blended concentrates then undergo drying to reduce moisture content. At this stage the concentrate is dried to 0.2 per cent moisture, usually using rotary, multicoil or fluidized bed dryers, operating at an outlet temperature ranging from 100 °C to 200 °C. Dry concentrate is then sent to smelting vessel and dust from the dryer process gas is removed in baghouses or ESPs. For facilities using IsaSmelt or similar technologies, the concentrate blend is not dried prior to introduction to the smelting vessel and conversion to a molten matte-slag mixture.

### 2.3.2 Roasting

Older technologies may still be used where concentrates are roasted prior to smelting. In facilities conducting this process, the blended concentrates are first roasted to convert the copper sulfides to oxides before treatment in the smelter. The roasting process gas, which contains sulfur dioxide and some mercury, is treated using scrubbers and ESPs to remove particulate matter. The gas is then sent to the acid plant.

### 2.3.3 Smelting

Once dried, the blend of concentrates and fluxes is smelted to produce a matte (or less frequently to blister copper), usually in an oxygen-enriched atmosphere in a smelting furnace. Several types of copper smelting processes exist which include flash smelting and bath smelting. Another process, not shown in figure 3, involves a multi-furnace continuous smelting and converting stage, which produces blister copper.

In particular, flash smelting is widely used, as it is an efficient technology whereby the heat released from the oxidation of the sulfide minerals drives the smelting process. In addition to producing the matte (or, less frequently, blister copper), the smelting produces a slag. The operating temperature of the furnaces is 1230–1250 °C. At this temperature, elemental mercury and mercury sulfide compounds will be completely volatilized. The process gas is captured and sent to the gas cleaning system.

### 2.3.4 Converting

For smelting processes that produce a copper matte, the matte is then transferred to the next stage in the process: converting of matte or copper alloy (produced from the cleaning of what is known as “direct to blister” smelting slag) to blister copper. A by-product of this process is the production of converter slag, which is reprocessed to recover copper in a slag cleaning furnace or returned to the smelting furnace. Process gas generated from the converters undergoes particulate matter removal and is finally mixed with the gases from the smelting furnace before entering the gas cleaning system of the sulfuric acid plant.

### 2.3.5 Refining and casting

Blister copper is then refined in anode furnaces, mainly to eliminate oxygen, sulfur and trace contaminants. The process gas generated in the anode furnaces is treated in a wet scrubber and then in a wet ESP or in a baghouse. Refined copper is cast into anodes. The final stage of copper production is electro-refining of anodes to copper cathodes containing more than 99.995 per cent of copper.

### 2.3.6 Slag cleaning

The molten slag produced in the smelting furnace and converters may be treated in an electric slag cleaning furnace to recover copper and other valuable metals contained in the slag. This produces a high grade matte which is transferred to the converters. The final slag may be granulated with water. The slag is either sent for disposal or used as an aggregate material.

In processes conducting direct smelting to blister copper, slag cleaning can produce copper alloys, which are sent to the smelter for reprocessing in converters.

Alternatively, instead of treatment in a slag cleaning furnace, slag cleaning can be carried out using mineral processing techniques. After slow cooling, the slag is crushed, milled and processed through flotation. A concentrate containing copper is produced and returned to smelting.

### 2.3.7 Sulfuric acid plant

Smelting and converting process gases are directed to the gas cleaning section of the sulfuric acid plant. The process gas is first cooled and treated to remove particulate matter, metals and acid mist using gas cleaning devices such as scrubbers and wet ESPs. During gas cleaning, the gas is cooled down to 35–40 °C. Most of the mercury coming from the smelter is removed at this stage by the three following mechanisms:

A portion of the mercury reacts to form solid mercury sulfate, which is removed as a sludge.

Elemental mercury is condensed by rapid quenching and cooling in scrubbers and packed cooling towers.

Selenium present in the copper concentrates is liberated in the smelting and converting processes and is contained in the smelter process gas as selenium oxide. Selenium oxide dissolves in the weak acid scrubbing solution and is immediately reduced by sulfur dioxide to form red selenium, which reacts with the elemental mercury to form solid mercury selenide (HgSe). Mercury selenide is a compound of extremely low solubility in water, stable in acidic conditions.

Following gas cleaning, specific mercury removal technology may be required before acid production to remove any remaining mercury in the process gas to meet commercial standards. The emissions from the final stack are expected to contain trace concentrations of mercury. The management of mercury-containing residues and sludges resulting from gas cleaning or mercury removal processes, including storage, disposal and trade, should be consistent with other relevant articles of the Convention.

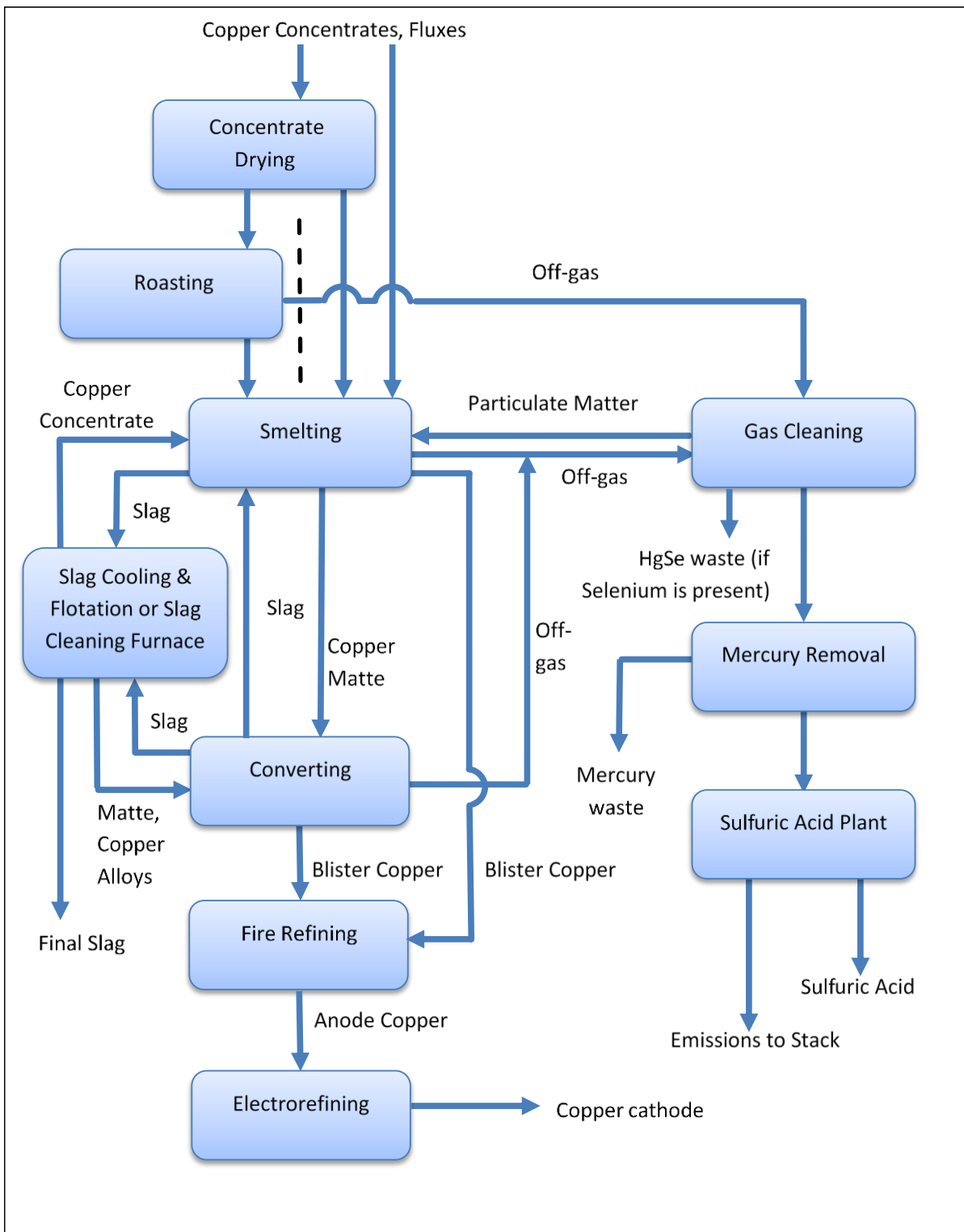

Figure 3: Processes in primary copper production

## 2.4 Process steps in gold production

Some gold ores require pretreatment before leaching while other ores can be leached directly. This section will focus on those ores that require roasting as a pretreatment to leaching, since Annex D to the Minamata Convention covers roasting. An overview of the processes involved is given in Figure 4.

### 2.4.1 Roasting

Ground gold ore, typically containing mercury at 0–100 ppm, is fed into the roaster. Roasters operate at 500–600 °C, the heat being used to oxidize both the sulfur and the carbon from the ore so that the gold can be leached and

recovered. The elevated temperatures cause the mercury contained within the ore to be volatilized. The gases produced from the roasting process are treated through several steps, some of which are co-pollutant controls, and also specific unit processes that are applied to minimize mercury emissions to the greatest extent possible. These controls are described in greater depth in the case study presented separately. The overall mercury removal from the roaster off-gas is expected to be greater than 99 per cent based on installations of similar controls at existing commercial operations.

#### **2.4.2 Leaching**

Water is added to the roaster discharge into an agitated tank where the water and solids from the roaster are mixed, creating a slurry. This slurry is sent to a series of tanks where gold is leached from the slurry – a carbon-in-leach (CIL) circuit – using cyanide. Once dissolved, both gold and mercury complexes adsorb from the slurry solution on to activated carbon. The final slurry, now depleted of both gold and mercury, is treated in a neutralization and detoxification process and then discharged to the tailings impoundment facility as waste. The cyanide soluble mercury that remains in the tails solution from leaching will be a very small contributor to atmospheric mercury because of the very low vapour pressure of the cyanide mercury complex.

#### **2.4.3 Stripping and regeneration**

The loaded carbon from the CIL circuit is washed and then transferred to a vessel where gold and mercury are stripped from the carbon back into solution. This results in a solution high in gold content from which the gold can be extracted by electro-winning or precipitation as described below. After removing the gold from the carbon (stripping), the carbon is sent to a kiln for thermal regeneration and recycled back to the leaching stage.

Some adsorbed mercury remains on the stripped carbon. The carbon regeneration kiln is an enclosed vessel which heats the carbon to a temperature above 700 °C, drying the carbon and removing any remaining adsorbed mercury into a gaseous form. The vessel does not contain oxygen and this allows the carbon to be dried without being oxidized or burnt. The gas is vented and cooled; elemental mercury is condensed out and collected in fully contained industrial flasks. The management of mercury-containing materials, including storage, disposal and trade, should be consistent with other relevant articles of the Convention.

Any remaining gaseous mercury is then passed through a vessel with sulfur-impregnated activated carbon. The mercury in the gas chemically binds with the sulfur to form a stable cinnabar compound (mercury(II) sulfide).

The overall mercury removal from the carbon regeneration kiln vent gas is anticipated to be greater than 99 per cent based on experience with similar controls at other existing commercial operations. While carbon regeneration kilns are beyond the scope of Annex D of the Minamata Convention, it is important to note that they may, in instances where emissions are not controlled, be significant sources of mercury emissions.

#### **2.4.4 Refining**

The gold sludge from electro-winning or precipitation using zinc dust is filtered and then processed in a retort vessel. The retort heats the sludge above 600 °C to dry the solids and any mercury is removed in the vent gas. Retort gas is vented to gas-handling equipment to remove the mercury before the gold-bearing material is sent to the refining furnace. The retort gas is first cooled and condensed, collecting mercury in an elemental form. Any remaining mercury that was not condensed is then passed through a vessel containing sulfur-impregnated activated carbon. The mercury in the gas chemically binds with the sulfur to form a stable cinnabar compound. The overall mercury removal from the retort vent gas is anticipated to be greater than 99 per cent, based on installations of similar controls at an existing operation.

#### **2.4.5 Furnace**

The dried gold-bearing solids from the retorts are heated in a furnace to temperatures above the melting points of all the constituents in the charge to provide the final separation of gold from impurities. The vent gas is first passed through a baghouse to remove any particulate matter, including particle-bound mercury. The vent gas is then passed through a vessel containing sulfur-impregnated activated carbon where the mercury chemically binds with the sulfur to form a stable cinnabar compound. The overall mercury removal from the furnace vent gas is anticipated to be greater than 99 per cent, based on installations of similar controls at other existing operations. The mercury-containing waste should be disposed of in an environmentally sound manner. For purposes of clarification, it is noted that emissions from the furnace are not covered by Annex D of the Minamata Convention. Furthermore, furnaces are not likely to be more than minor sources of mercury emissions.

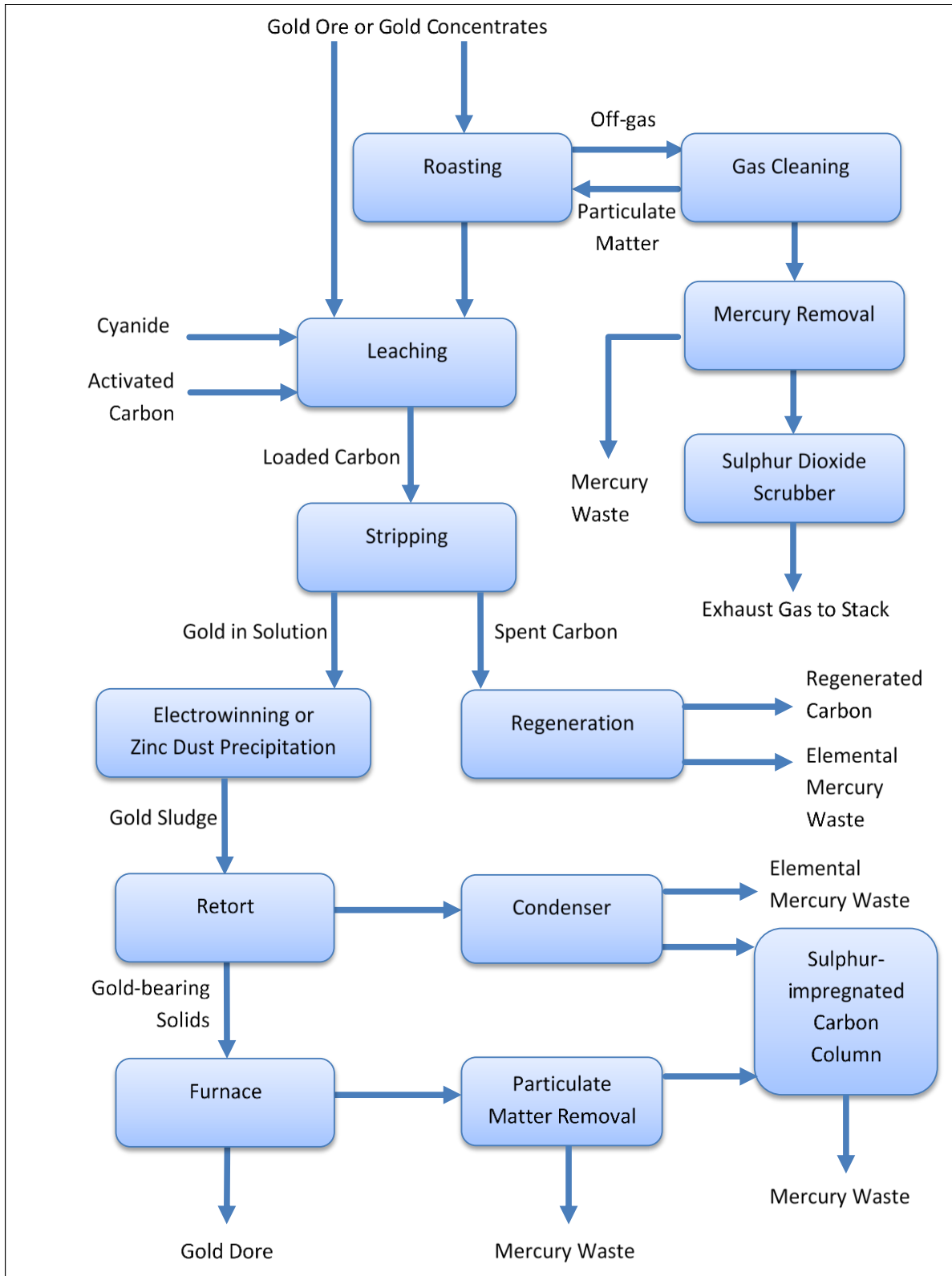

Figure 4: Processes in primary gold production

### 3 Emission control techniques

In the following sections the main mercury air emission abatement techniques relevant to the non-ferrous roasting and smelting and refining sector are described. In general, these rely on some form of mercury oxidation and interactions with materials such as mercury(II) chloride. This list does not include those techniques that are recognized to reduce mercury emissions to air by virtue of the co-benefit of capture of other pollutants – such as organic carbon compounds or other particulate matter. A cross-cutting section on multi-pollutant control technologies that provide a co-benefit for mercury emissions capture is also presented.

Mercury is volatile at the temperatures encountered in most abatement processes, and hence sector-specific techniques may be needed to remove it. In the case of mercury removal before a sulfuric acid plant, any residual mercury will be present in the acid that is produced. The quality of acid is often defined in terms such as commercial grade, technical grade, electrolytic grade, battery grade, food grade, etc. These terms are general in nature and may differ from supplier to supplier and from country to country. The product specification depends on the potential use of the acid and has been reported to be typically less than 1.0 ppm and equivalent to  $\sim 0.02$  mg/Nm<sup>3</sup> in the cleaned gas,<sup>35</sup> although for some applications significantly lower concentrations may be required.<sup>36</sup>

#### 3.1 Boliden Norzink process

##### 3.1.1 Description

The Boliden Norzink process (also called the Outotec chloride scrubber process or the Outotec BN process<sup>37</sup>) removes elemental mercury from waste gases of primary ore smelters by converting mercury into mercury(I) chloride, Hg<sub>2</sub>Cl<sub>2</sub> (also known as “calomel”). Calomel results from the reaction of mercury with mercury(II) chloride, HgCl<sub>2</sub>. Mercury(II) chloride is then recovered from some of the calomel by oxidation with chlorine and returned to the gas-cleaning process.

The process<sup>38</sup> takes place in a packed bed tower. Vaporous elemental mercury contained in the waste gas is oxidized by a water based scrubber solution of mercury(II) chloride:

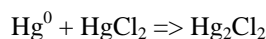

The tower consists of a vertical fiberglass reinforced cylindrical vessel through which the waste gas passes from the bottom up. The tower is filled with polypropylene packing (generally shaped like saddles). In the upper part of the tower the scrubbing solution is sprayed onto the top of the packing through a series of nozzles. A chevron or mesh-pad mist eliminator at the outlet of the tower prevents escape of the scrubbing solution from the system. The process temperature is about 40 °C or lower and the pressure drop by the scrubber tower is about 1 kPa.

The resulting calomel is insoluble. It precipitates from the liquor and is removed at the bottom of the tower as dense slurry. The liquor is then circulated back to the scrubber. Under optimized process conditions, elemental mercury reacts almost completely with mercury(II) chloride.

It is necessary to maintain a high mercury(II) chloride concentration in the circulated scrubbing solution to achieve an effective oxidization. Half of the slurry is therefore treated with chlorine gas to re-oxidize the precipitated mercury(I) chloride into mercury(II) chloride:

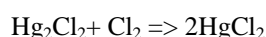

As soon as the treated calomel solution is completely regenerated, it is pumped into a storage tank. When the concentration of mercury(II) chloride in the scrubbing circuit depletes, regenerated mercury(II) chloride solution is added from the storage tank to maintain the concentration of mercury(II) chloride in the scrubbing circuit.

The net reaction of the process steps (a) and (b) is:

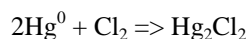

The remaining half of the calomel slurry is directed to a settler. The clarified solution overflows and is returned to the scrubbing tower pump tank. At the bottom of the settler, insoluble mercury(I) chloride settles into a conical tank. The solids pass to a second settler to concentrate further. Zinc dust can be added to support the precipitation. The solids resulting from the second settler are filled into storage drums for sale or for further internal processing. The calomel

<sup>35</sup> [www.mercuryconvention.org/Portals/11/.../EG1/EU\\_information.pdf](http://www.mercuryconvention.org/Portals/11/.../EG1/EU_information.pdf); accessed 24 March 2015.

<sup>36</sup> [http://www.sulphuric-acid.com/techmanual/Properties/properties\\_acid\\_quality.htm](http://www.sulphuric-acid.com/techmanual/Properties/properties_acid_quality.htm); accessed 24 March 2015.

<sup>37</sup> <http://www.outotec.com/en/About-us/Our-technologies/Gas-cleaning/Mercury-removal/#tabid-2>. accessed 24 March 2015

<sup>38</sup> [http://www.sulphuric-acid.com/techmanual/GasCleaning/gcl\\_hg.htm](http://www.sulphuric-acid.com/techmanual/GasCleaning/gcl_hg.htm); accessed 24 March 2015.

bleed can be finally disposed of or used for elemental mercury production. The mercury is then stored in secure storage vessels. Figure 5 shows a flow chart of the Boliden Norzink process.

The risk to workers' health from potential exposure to mercury(II) chloride or chlorine (highly toxic) should also be considered.

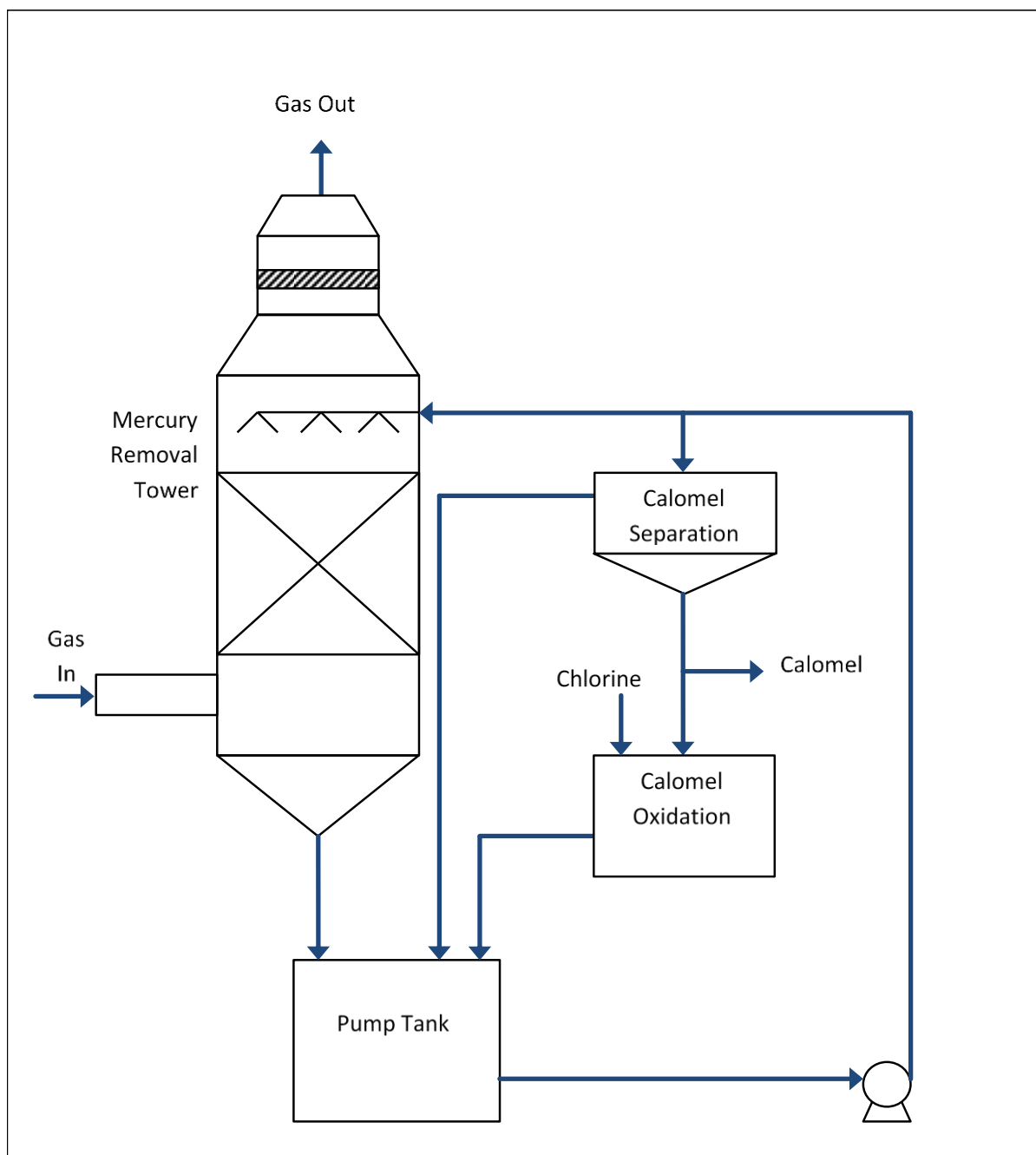

**Figure 5: Flow chart of the Boliden Norzink process with  $\text{Hg}_2\text{Cl}_2$  recovery (Hultbom 2003)**

### 3.1.2 Applicability

This process is applicable to all process gases from ore smelters, in particular for process gases containing  $\text{SO}_2$ . The technique is effective for varying input levels of mercury and also for high mercury content and is used effectively in about 40 plants worldwide.



### 3.1.3 Performance

Removal efficiency depends on the mercury content of the waste gas inlet and is typically 99.7 per cent. Typical mercury outlet concentration is 0.3–0.5 ppm<sup>39</sup> (Hultbom 2003; UNECE 2013). An outlet concentration of 0.3–0.5 ppm is also achieved with high mercury inlet concentrations exceeding 100 mg/Nm<sup>3</sup> (Hultbom 2003).<sup>40</sup>

**Table 3**

Performance of Boliden Norzink process at Boliden Rönnskar<sup>41</sup> (BREF NFM 2014)

Gas flow 30,000 Nm <sup>3</sup> /h	Before [µg/Nm <sup>3</sup> ]	After [µg/Nm <sup>3</sup> ]	Reduction efficiency [%]
High inlet concentration	9879	30	99.7
Low inlet concentration	51	13	74

### 3.1.4 Cross-media impacts

Cross-media impacts of the process include the following:

- Impacts on air and water due to the production of solid calomel waste, by leaching or vaporization of mercury.

### 3.1.5 Costs of installation and operation

Because of the low process temperature (below 40 °C), mainly plastic materials are used for the construction.

Operating costs are low as they are restricted to:

- Electric energy consumption for circulating pumps;
- Increased electric energy consumption for fans to compensate for the pressure drop created by the scrubbing tower;
- Chlorine gas consumption for mercury(II) chloride recovery.

Operating costs are practically independent of the mercury level in the waste gas<sup>41</sup> (Hultbom 2003) and the process is known to be economically viable. At Aurubis Hamburg, the investment costs for the installation of the mercury removal plant ran up to €5 million (including condenser, heaters, bag filter, injection system, absorber and fans) (BREF NFM 2014).

## 3.2 Selenium filter

### 3.2.1 Description

The selenium filter process<sup>37,38</sup> removes low elemental mercury content from waste gases of primary ore smelters by converting selenious acid into red amorphous selenium, reacting with gaseous mercury to form mercury(II) selenide.

The selenium filter is a fixed bed filter with a large surface area, designed to achieve an intimate contact with the active substance. A porous inert material similar to a catalyst support is used. This material is impregnated with red amorphous selenium. The impregnation is achieved by drying selenious acid solution in the presence of SO<sub>2</sub> to precipitate red amorphous selenium:



The red amorphous selenium reacts with the mercury in the gas to form mercury(II) selenide:

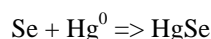

The contact time in the filter is about 1–3 seconds.

The filter remains effective until the level of mercury in the filter reaches 10–15 per cent. The filter is then treated to recover the mercury and regenerate the selenium.

The vapour pressure of mercury at temperatures of 0–100 °C is very low compared to HgSe. Selenium is well suited as a control substance as its vapour pressure is also very low at these temperatures, and selenium losses are minor.

<sup>39</sup> <http://www.outotec.com/en/About-us/Our-technologies/Gas-cleaning/Mercury-removal/>; accessed 24 March 2015.

<sup>40</sup> Nm<sup>3</sup> is a normal cubic metre and refers to gas measured at a pressure of 1 atmosphere and a temperature of 0 °C.

<sup>41</sup> United Nations Economic Commission for Europe, Protocol on Heavy Metals, available at: [http://www.unece.org/env/lrtap/hm\\_h1.html](http://www.unece.org/env/lrtap/hm_h1.html); accessed 24 March 2015.

The filters can operate at temperatures up to 110 °C with water-vapour-saturated gases. Condensation inside the filters, however, should be avoided.

The pressure drop is of the order of 600 Pa for a one-stage filter with a three-second retention time.

The selenium filter can produce virtually mercury-free waste gases from smelters. It can also be applied as a second waste gas treatment step to lower the mercury content before the gas enters a subsequent acid plant producing mercury-free acids.

Compared with other fixed bed mercury adsorbents such as activated carbon, a selenium filter has the advantage of reacting selectively with mercury. Unwanted side reactions will not occur as the selenium mass has no known catalytic activity. This makes it possible, for example, to use the selenium filter for mercury removal in moist SO<sub>2</sub>-containing gases. With activated carbon, SO<sub>2</sub> will be oxidized to SO<sub>3</sub>, which combines with water vapour to form sulfuric acid, clogging the filter (Hultbom 2003).

Alternatively, to achieve mercury concentrations of 0.05 mg/Nm<sup>3</sup> and less, extreme gas cooling to temperature levels well below 0 °C would be needed to separate particulate mercury compounds and liquid mercury. The same residual level can be achieved by collecting mercury as mercury(II) selenide (HgSe) at temperatures up to approximately 140 °C (Hultbom 2003).

### 3.2.2 Applicability

The applicability is proven in at least six plants worldwide.

### 3.2.3 Performance level

Removal efficiency depends on the retention time. To achieve removal efficiencies of 95 per cent, a retention time of three seconds is normally needed (Hultbom 2003). Typically, removal efficiencies of 90 per cent are achieved.<sup>38</sup> The minimum expected hourly average mercury outlet concentration<sup>41</sup> is less than 0.01 mg/Nm<sup>3</sup> (UNECE Heavy Metals Protocol 2013). The following tables show typical mercury reductions.

**Table 4**

Performance of selenium filter process at Boliden Rönnskar<sup>41</sup> (copper-lead-zinc smelter) (BREF NFM 2014)

Gas flow 80,000 Nm <sup>3</sup> /h	Before [µg/Nm <sup>3</sup> ]	After [µg/Nm <sup>3</sup> ]	Reduction efficiency [%]
High inlet concentration	1008	48	95
Low inlet concentration	42	12	71

**Table 3**

Typical results of selenium filter process (Hultbom 2003)

Gas flow	Before [µg/Nm <sup>3</sup> ]	After [µg/Nm <sup>3</sup> ]	Reduction efficiency [%]
High inlet concentration	6000	<50	99

### 3.2.4 Costs of installation and operation

The investment cost is proportional to the amount of gas flow.

When the selenium mass is saturated with mercury it must be replaced. This represents the major cost for this technology, and it is basically proportional to the quantity of mercury removed (Hultbom 2003).

Costs for installation of the selenium filter are often compared with those for the Boliden Norzink process in situations where they are the most appropriate technologies. At lower gas flow rates the relative investment cost is lower than those for the Boliden Norzink process, as it is a scrubbing method which requires more equipment. Conversely, the opposite is true for higher flow rates as the scale-up cost for a scrubber is smaller than for a fixed bed filter (Hultbom 2003).

For higher gas flow rates with high incoming levels of mercury, the Boliden Norzink process is the more economical; it has been reported, however, that to meet the most stringent demands for mercury removal it is possible to combine the Boliden Norzink process and the selenium filter (Hultbom 2003).

Industry sources report indicative costs for a selenium filter with 200,000 m<sup>3</sup>/h capacity of an initial investment of about €3 million plus 70 tons of selenium at a price of €35,000 per ton.

### 3.2.5 Cross-media impacts

There are potential impacts on air and water due to vaporization of elemental or oxidized mercury from the production of solid mercury(II) selenide waste. The waste needs to be stabilized before further treatment. The management of mercury-containing materials, including storage, disposal and trade, should be consistent with other relevant articles of the Convention.

## 3.3 Activated carbon

### 3.3.1 Description

Sulfur-impregnated activated carbon<sup>42</sup> is a proven technology that is used in the industrial gold sector to control mercury air emissions. Activated carbon can be applied in either a fixed bed setting or through carbon injection. Mercury contained within the gaseous emissions reacts with the sulfur-impregnated carbon as it passes through the bed, forming mercury(II) sulfide (HgS). Activated carbon has the advantage of removing all types of mercury air emissions, including oxidized, particle-bound and elemental mercury.

This control technology captures mercury as stable mercury sulfide (HgS) absorbed within sulfur-impregnated active carbon. It is at an advanced level of development and is a proven technology commonly used in the non-ferrous sector, with significant application in the gold mining sector together with some use in other metals. It is also commonly used in the power industry.

When a source uses activated carbon, it will need to overcome some limitations. First, the maximum operating temperatures vary by manufacturers. There may be a need to pre-cool the gas stream. Second, if the gas stream has greater than 10 per cent moisture, pretreatment is required to reduce moisture. Finally, there is a risk of fire associated with the use of activated carbon as a mercury control; many facilities have been using activated carbon without incident, however, for many years. With proper management, these risks can be mitigated and minimized.

### 3.3.2 Applicability

Activated carbon can be used to remove all forms of mercury emissions: gaseous and particulate, elemental and oxidized. It is able to adsorb from 10 to 40 per cent by weight of mercury before it needs to be replaced. In addition, sulfur-impregnated carbon (15–20 per cent by weight) is efficient in forming a stable sorbent.

### 3.3.3 Performance level

A properly designed and maintained sulfur-impregnated carbon adsorption system located downstream of a condenser is able to capture 99 per cent of the mercury, achieving a concentration of 0.01 mg/m<sup>3</sup>. Carbon manufacturers' mercury adsorption specifications vary from 10 to 40 per cent. The carbon, however, is typically loaded with mercury to 20 per cent by weight before replacement. Spent adsorbent is disposed of as hazardous waste or retorted to recover the elemental mercury. The management of mercury-containing materials, including storage, disposal and trade, should be consistent with other relevant articles of the Convention.

### 3.3.4 Costs of installation and operation

One factor driving capital cost is the volumetric flow rate of the gas to be treated. Figure 6 summarizes equipment and materials for a system involving scrubbing, cooling, condensing, and carbon adsorption beds. The cost of construction and installation is not included, given the variability due to geography and the complexity of the associated projects.

<sup>42</sup>There are other types of activated carbon including halogen-, fluoride-, iodine-, and bromine-impregnated activated carbon that are also being used for mercury control but it is unclear whether the non-ferrous sector is actively using these types of activated carbon. These types may more appropriately belong in our section on emerging technologies. For that reason, the focus of this chapter is on sulfur-impregnated carbon.

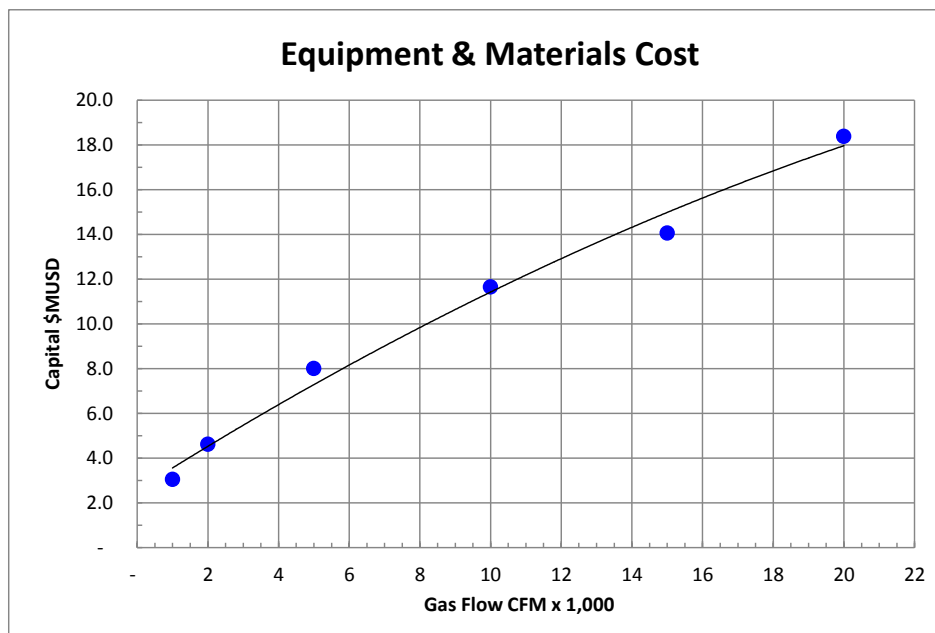

**Figure 6: Capital cost of equipment and materials for sulfur-impregnated activated carbon filters as a function of gas flow (CFM: cubic feet per minute, 1 CFM = 1.7 m<sup>3</sup>/hr)**

The main cost of the operation is replacement and disposal or retorting of the spent sulfur-impregnated activated carbon. The rate of replacement is driven by the mercury content within the gas flow. The replacement cost of sulfur-impregnated carbon in North America is \$6.6/kg.

### 3.3.5 Co-benefits

Activated carbon which is not sulfur-impregnated is very effective at removing organic compounds, such as dioxins or furans and volatile organic compounds (VOCs) contained within the gas stream. If organic compounds are present, what is known as an “activated carbon pre-cleaning bed” is commonly installed to remove them ahead of the sulfur-impregnated bed intended for mercury. Without the pre-cleaning bed, organic compounds would adsorb onto the sulfur-impregnated carbon, reducing capacity for subsequent mercury removal and increasing costs occasioned by more frequent bed replacements (Krumins *et al.* 2013).

### 3.3.6 Cross media impacts

Spent mercury-loaded sulfur-impregnated carbon may require disposal as hazardous waste. The management of mercury-containing materials, including storage, disposal and trade, should be consistent with other relevant articles of the Convention.

## 3.4 DOWA filter process (lead(II) sulfide covered pumice filter)

The lead(II) sulfide process is a dry media technique used to remove mercury from flue gases generated in non-ferrous metal smelters. The gases containing volatile mercury are passed through a tower packed with lead-sulfide-coated balls, such as granulated pumice, to make the gas contact effectively. Mercury, which has a high vapour pressure, is converted into its sulfide, which shows a very low vapour pressure, by contacting the gas with lead(II) sulfide. For the lead(II) sulfide process, a mercury removal efficiency of 99 per cent has been measured, resulting in mercury emission concentrations of 0.01-0.05 mg/Nm<sup>3</sup>.

Indicative costs have been obtained from industry sources: a Dowa tower with 200,000 m<sup>3</sup>/h gas capacity has an initial investment cost of about €5.5 million, plus the cost for 500 m<sup>3</sup> of the filter materials of €1,800 per ton, and has a lifetime of approximately 5–10 years.

## 3.5 Jerritt process

### 3.5.1 Description

The Jerritt process is currently in use at one gold mine, and illustrated in figure 7. It removes elemental mercury from waste gases from the roasters by converting mercury into mercury(II) chloride, HgCl<sub>2</sub>. Mercury(II) chloride results from the reaction of mercury with dissolved chlorine, Cl<sub>2</sub>. A bleed stream containing mercury(II) chloride is then treated by direct electro-winning to recover elemental mercury, treated with zinc dust to precipitate mercury(I) chloride or returned to the thickener for recovery of any gold values.

The Jerritt process was developed and first installed in 2009 by the Canadian company Yukon-Nevada Gold Corporation at its Jerritt Canyon whole ore roasting facility (Elko, Nevada, United States). Later, in 2010, the system was installed on its ore dryer.

The process takes place in a packed bed tower. Vaporous elemental mercury contained in the waste gas is oxidized by a water-based scrubber solution of dissolved chlorine:

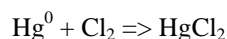

The tower consists of a vertical fiberglass-reinforced cylindrical vessel through which the waste gases pass from the bottom up. The tower is filled with polypropylene saddle packing. In the upper part of the tower the scrubbing solution is sprayed on to the top of the packing through a series of nozzles.

A chevron mesh mist eliminator at the outlet of the tower prevents escape of the scrubbing solution from the system. The process temperature is about 40 °C and lower. Pressure drop through the scrubber tower is about 1 kPa.

The liquor is circulated back to the scrubber and a bleed stream equal to the volume of the pH controlling solution and the demister spray is removed from the recirculating solution. Under optimized process conditions, elemental mercury reacts almost completely with the dissolved chlorine.

The risk to workers' health from potential exposure to mercury(II) chloride (highly toxic) should also be considered.

### 3.5.2 Applicability

This process is applicable to all waste gases from roasters, in particular for waste gases where the SO<sub>2</sub> has been removed by scrubbing. The technique is effective for high input levels of mercury as produced by the Jerritt roasters, and also for low input levels of mercury as produced by the Jerritt ore dryer.

### 3.5.3 Performance

Removal efficiency is typically 99.97 per cent. Typical mercury outlet concentration is 0.004–0.005 ppm.

### 3.5.4 Cross-media impacts

The cross-media impacts of this process include:

- Impacts on air and water due to the production of solid calomel waste (avoided if the electro-winning of mercury is applied to mercury(II) chloride or if the scrubber bleed is disposed of to the roaster thickener).

### 3.5.5 Costs of installation and operation

Owing to the low process temperature (below 40 °C), mainly plastic materials are used for the construction.

Operating costs are low as they are restricted to:

- Electric energy consumption for circulating pumps;
- Increased electric energy consumption for fans to compensate the pressure drop created by the scrubbing tower;
- Chlorine gas consumption.

Operating costs are practically independent of the mercury level in the waste gas.

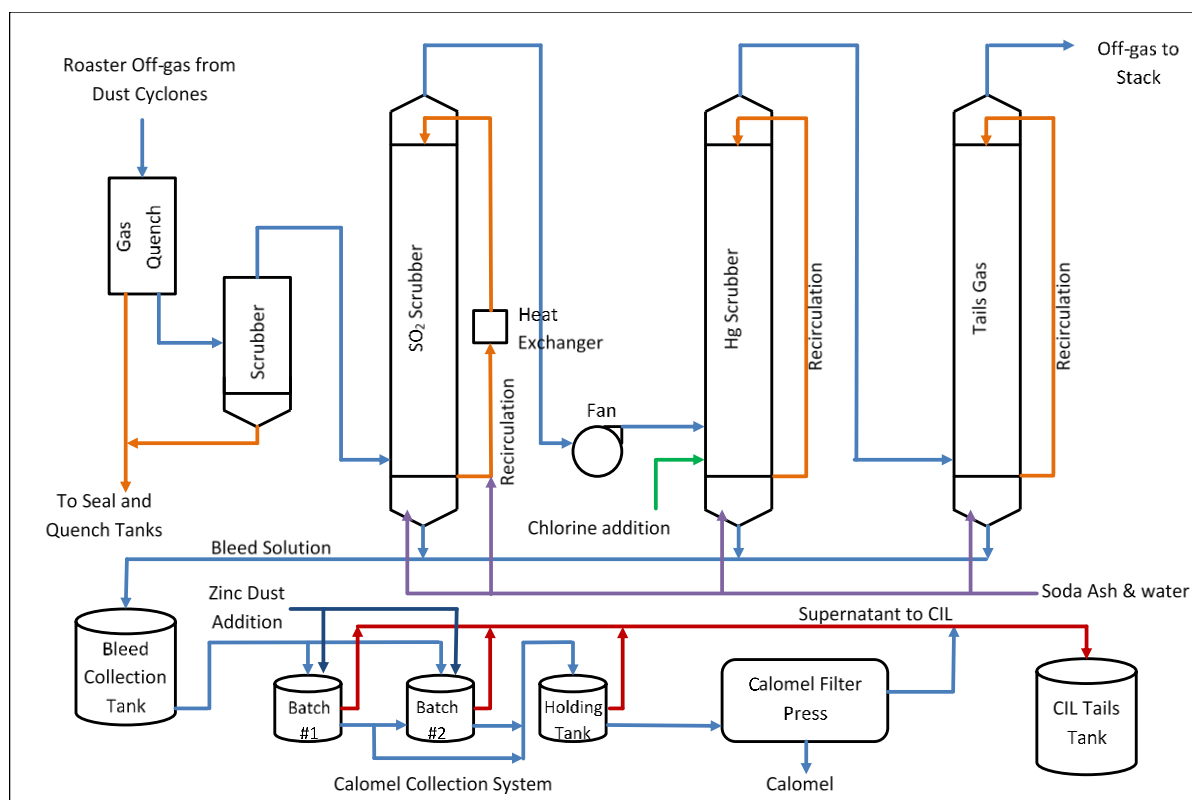

Figure 7: Flow chart of Jerritt process with  $\text{Hg}_2\text{Cl}_2$  recovery option

### 3.6 Co-benefits of common air pollution abatement technologies and acid plants in mercury control

#### 3.6.1 Pollution abatement technologies

A cross-cutting section on common pollution abatement technologies that provide a co-benefit for mercury emissions capture is presented in the common techniques chapter of the BAT/BEP guidance document. The current section discusses the applicability of those techniques to the non-ferrous metals sector.

##### 3.6.1.1 Bag filters

The use of bag filters is common in the non-ferrous metals sector, as this technique provides the highest collection efficiency among the particulate control methods. The dust cake collected on the filters can be removed periodically using methods such as reverse airflow, mechanical shaking, vibration and air pulsing. The dust cake can then be recycled in the smelter process to recover any metals of value. This technique is effective in capturing mercury in particulate form, or mercury that has adsorbed onto particles.

##### 3.6.1.2 Electrostatic precipitators

Both wet and dry electrostatic precipitators (ESPs) are widely used in the non-ferrous metals sector as a primary stage of particulate matter removal. In dry ESPs, the dust that collects on the charged plates is removed by rapping or vibration. The dust is usually recycled in the smelter process.

In wet ESPs, the dust is removed by flushing the plates, usually with water. An effluent and sludge are produced, which can be recycled in the process if they contain valuable materials, or disposed of. Under certain circumstances, wet ESPs have been shown to effectively remove mercury in both gaseous and particulate form when operated in combination with other techniques such as scrubbers and gas coolers.

##### 3.6.1.3 Scrubbers

The non-ferrous metals sector regularly uses wet scrubbers, such as for cooling gases and removing particulate matter and impurities such as  $\text{SO}_3$ ,  $\text{HCl}$  and  $\text{HF}$  as part of the gas cleaning process prior to sulfuric acid production. This technique produces an effluent and sludge. The effluent can be reused in the scrubber, while the sludge can be recycled in the smelting process or disposed of. The management of mercury-containing materials, including storage, disposal and trade, should be consistent with other relevant articles of the Convention.

Wet scrubbers are effective in removing mercury in particulate form, or mercury that has adsorbed onto particles. Wet scrubbers are not very effective, however, in removing gaseous elemental mercury from gas streams, unless it contains selenium compounds.

### 3.6.2 Combined gas cleaning and acid plants

#### 3.6.2.1 Description

The combination of gas cleaning equipment with sulfuric acid plants is a proven technology for sulfur emissions control in the non-ferrous metals industry and its use is common worldwide. Under certain conditions, operation of an acid plant with gas cleaning equipment has also been shown to be effective in capturing mercury from the gas stream through the use of traditional particulate matter control techniques that result in mercury removal efficiencies equivalent to the use of specific mercury BAT. In these cases, where the ore properties and process conditions permit, almost all of the mercury is removed in the gas cleaning before the acid plant and residual mercury is removed from additional gas cleaning after materials are sent to the acid plant.

A recent survey<sup>43</sup> completed in Japan has shown that many companies are successfully relying on gas cleaning and sulfuric acid plants to remove the mercury from the flue gases in metal smelting facilities. The survey shows that mercury is being effectively captured with the use of this method at certain copper, lead and zinc smelters.

#### 3.6.2.2 Applicability

Sulfuric acid plants combined with gas cleaning that effectively remove mercury have been implemented at copper, zinc and lead smelters worldwide.

An example of such a plant was provided in a detailed Japanese study (Takaoka et al. 2012) at an Imperial Smelting Process (ISP) zinc smelter which used a comprehensive mercury mass balance as illustrated in Figure 8.

#### 3.6.2.3 Performance levels

The results of the Japanese study show the potential effectiveness of the combined gas cleaning and sulfuric acid plant approach in capturing mercury. The total mercury concentration in the flue gases was found to be in the range 1.7–6.1  $\mu\text{g}/\text{Nm}^3$  (Takaoka et al. 2012).

#### 3.6.2.4 Costs

The combination of gas cleaning and sulfuric acid plants is standard technology for collecting sulfur dioxide from flue gas in smelters that process sulfidic concentrates. In cases where mercury can be recovered with this combination of technology at an efficiency equivalent to the use of specific mercury BAT, additional capital investment in mercury removal would not be required.

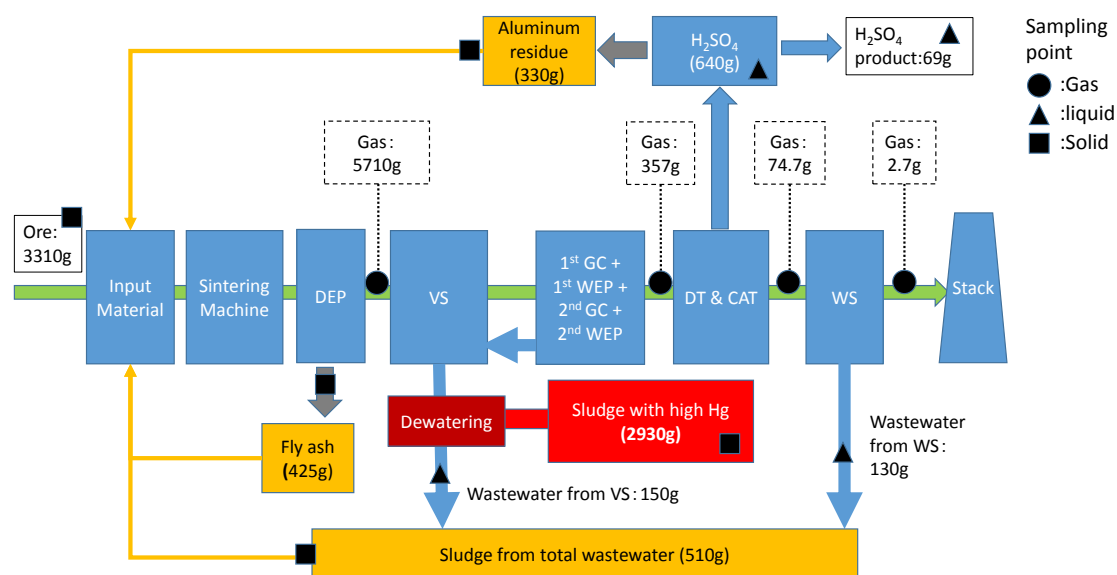

Key: DEP: dry electrostatic precipitator, VS: Venturi scrubber, GC: gas cooler, WEP: wet electrostatic precipitator, DT: dehydration tower, CAT: converting process and absorption tower, WS: wet scrubber

<sup>43</sup> [JMIA bulletin "Kozan (<http://www.mmf.or.jp/>)" for the April 2015] Takashi Shimizu: Mercury Removal from the Nonferrous Smelter's Off-gas in Japan.

**Figure 8: Mercury mass balance around sulfuric acid production at Japanese ISP zinc plant (Takaoka et al. 2012)**

**3.6.2.5 Co-benefits**

Combined gas cleaning with a sulfuric acid plant is very effective at capturing sulfur dioxide. In fact, the primary purpose for installing a sulfuric acid plant is the collection of sulfur dioxide and the production of saleable sulfuric acid.

**3.6.2.6 Cross-media impacts**

There are potential impacts on air and water due to the production of a solid mercury waste (sludge). The management of mercury-containing materials, including storage, disposal and trade, should be consistent with other relevant articles of the Convention.



## 4 Emerging and other processes

In this section, mercury removal processes which are emerging or not widely in application are considered.

### 4.1 Selenium scrubber

The selenium scrubber (Sundström 1975; Reimers et al. 1976; Coleman 1978; Habashi 1978) is a wet scrubber which uses the reaction between mercury and amorphous solid selenium in sulfuric acid. It is mainly used to remove high concentrations of mercury vapour. The acid concentration is maintained between 20 and 40 per cent. The acid concentration must be kept within these limits because complex and highly soluble selenium sulfur compounds are formed at low acid concentrations, making it ineffective in reacting with the mercury in the gas. At higher acid concentrations, the oxidizing power of the acid will result in the formation of selenium dioxide or selenite.

If the gas being treated contains sufficient selenium, there may not be a requirement to add selenium to the scrubber solution. The mercury reduction efficiency of a selenium scrubber is about 90–95 per cent, resulting in mercury concentrations of about 0.2 mg/m<sup>3</sup>. At low incoming mercury concentrations, however, the removal efficiency may be less than 90 per cent.

### 4.2 Removal by reaction with sulfuric acid

#### 4.2.1 Description

A number of techniques for controlling mercury emissions from smelting and roasting have been developed based on their reaction with sulfuric acid. The Bolkem process is located in the acid plant, and the removal is achieved by 99 per cent sulfuric acid. This acid comes from the absorption part of the acid plant and oxidizes the mercury at ambient temperature. The resulting acid that contains mercury is diluted to 80 per cent and the mercury is precipitated as sulfide with thiosulfate. After filtering off the mercury sulfide, the acid is returned to the absorption stage. No acid is therefore consumed in the process.

Mercury may also be removed before the washing step in the acid plant.<sup>44</sup> Gas at temperatures of about 350 °C is washed countercurrently with 90 per cent sulfuric acid at about 190 °C in a packed bed tower. The acid is formed in situ from the SO<sub>3</sub> in the gas. The process is based on converting the elemental mercury in the gas into a sulfate. The acid is recirculated until the solution becomes saturated with HgSO<sub>4</sub> and precipitation begins. The crystals of HgSO<sub>4</sub> are then separated in a thickener. In addition to removing mercury, other contaminants in the gas will be removed in the scrubber. Mercury can be recovered by mixing the solids with calcium oxide, and then heating to distil away the mercury, which can then be dealt with in accordance with the Convention.

Alternatively, mercury may be precipitated and the mercury sludge removed from the cooled acid, filtered and washed. Part of the acid is then recycled to the scrubbing step. In a revision to this process, mercury is removed from the gases by washing with a solution of selenium ions, and selenium metal is produced along with mercury(II) selenide.

A thiosulfate process has also been described by Schulze (2009). In this process the absorption efficiency of mercury depends on the acid strength and acid temperature. The lower the acid temperature and the higher the acid concentration, the higher is the absorption efficiency. To avoid an accumulation of mercury in the product acid it is essential to absorb the mercury vapour in a two-stage drying tower unit running with different acid concentrations in which the acid concentration in the second drying tower is higher than the acid concentration of the downstream absorption units.

The mercury-containing acid of the drying towers has to be cleaned before discharging into the absorption circuits. The acid streams are therefore gathered and treated in reaction units with sodium thiosulfate (Na<sub>2</sub>S<sub>2</sub>O<sub>3</sub>·5H<sub>2</sub>O).

The total amount of acid of both drying towers is stripped with air in a stripping tower to remove the dissolved sulfur dioxide. The stripped acid is discharged to a reaction tank in which a solution of 40 per cent sodium thiosulfate and a filter aid medium are added. Sulfur is formed according to the reaction:

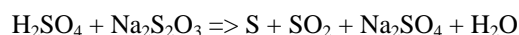

The sulfur reacts with the mercury in the acid to form mercury(II) sulfide, which precipitates. The temperature at this stage is about 50 °C and the acid concentration is about 80 weight per cent. The treated acid overflows to a maturing tank in which the reaction is completed.

These processes have been included in this section. It is not clear, however, how many smelters or roasters are currently using these processes.

<sup>44</sup> [http://www.sulphuric-acid.com/techmanual/GasCleaning/gcl\\_hg.htm](http://www.sulphuric-acid.com/techmanual/GasCleaning/gcl_hg.htm); accessed 16 April 2015.

## **5 Best available techniques and best environmental practices**

### **5.1 BAT overview**

2 An overview of techniques that could be considered in identifying BAT for mercury reduction in the non-ferrous sector is given in Table 5. As described in section 3.6, the co-benefits of gas and particulate pollution abatement techniques and acid plants may also achieve acceptably low emissions of mercury,

**Table 5**

Summary of mercury-specific control techniques for the non-ferrous metal smelting and roasting processes (typical emission performance is shown and may not be demonstrative of all possible situations)<sup>38</sup>41 (UNECE 2013)

Mercury control technique	Description	Typical performance (mercury removal efficiency) <sup>a</sup>	Advantages/comments	Disadvantages
<b>Boliden-Norzink</b>	Based on a wet scrubber using the reaction between mercury(II) chloride and mercury to form mercury(I) chloride (calomel), which precipitates from the liquor.	99.7% – inlet concentration of ~ 9900 µg/m <sup>3</sup> 74% – inlet concentration 51 µg/m <sup>3</sup>	Widely demonstrated	Chlorine gas handling Calomel handling Calomel disposal as hazardous waste
<b>Selenium filters</b>	The selenium filter consists of a porous inert material soaked with selenious acid which is then dried to precipitate red amorphous selenium. The red amorphous selenium reacts with the mercury in the gas to form HgSe.	95% – inlet concentration 1000 µg/m <sup>3</sup> 71% – inlet concentration 42 µg/m <sup>3</sup>	Especially suited to low mercury concentrations in the gas  Successful installation at metallurgical plants	Limited inlet mercury concentration Spent filter requires environmentally sound disposal
<b>Activated carbon filter beds</b>	Activated carbon is well known for its adsorption properties. For the adsorption of mercury, activated carbon can normally adsorb 10-12 per cent of its own weight.	97% – inlet concentration 1,200 µg/m <sup>3</sup> 93% – inlet concentration 37 µg/m <sup>3</sup>	Sulfur-impregnated activated carbon is commercially available Removes Hg <sup>0</sup> and other species Low potential for leaching of mercury from spent carbon	Spent carbon requires disposal in landfill
<b>DOWA</b>	Based on the adsorption of mercury onto pumice stones coated with lead sulfide	97% – inlet concentration 50 µg/m <sup>3</sup> 88% – inlet concentration 11 µg/m <sup>3</sup>		Not widely used Mercury sulfide disposal as hazardous waste
<b>Jerritt</b>	Based on conversion of elemental mercury to mercury (II) chloride by reaction with dissolve chlorine Cl <sub>2</sub>	99.97%	Very high mercury removal efficiency	By product disposal consistent with other relevant articles of the Convention

<sup>a</sup> Performance data based on data for Boliden's Rönnskärsverken Copper-Lead-Zinc Smelter, as reported in UNECE 2013

### 5.1.1 Some other considerations in the choice of mercury control in smelting and roasting in the non-ferrous metals sector

General principles for the choice of BAT for the point source categories listed in Annex D are described in the introductory chapter to this guidance. Here some additional aspects of mercury chemistry which might have an influence on the choice of mercury controls in the non-ferrous sector are discussed. These are not meant to be prescriptive and may be less applicable to some of the metals listed in Annex D, in particular gold.

Mercury may be present in the process gases from smelting and roasting operations as elemental ( $\text{Hg}^0$ ) or oxidized ( $\text{Hg}^{2+}$ ) mercury, and in the gas or particulate phase. In many cases oxidized mercury is efficiently removed in the normal gas cleaning systems employed in these processes to control acid gases ( $\text{SO}_2$ ,  $\text{NO}_x$ ) and fine particles. It is therefore essential that these perform well, to reach a low total residual content of mercury in the cleaned gas. This is especially important for the wet ESPs in wet gas cleaning systems. Efficient gas cleaning is also important as impurities in the gas could result in unwanted side reactions in the mercury removal stage. For example, the selenium filter, which is of the fixed bed type, is sensitive to dust deposits on the active porous particles.

It is considerably more difficult to remove elemental mercury than oxidized mercury and most of the commercial technologies are designed to remove vaporous elemental mercury and depend on upstream conventional gas cleaning to achieve high mercury removal. The mercury removal stage is normally installed when mercury content of feedstock or characteristics of the ore make conventional gas cleaning insufficient to remove sufficient amounts of mercury.

Table 6 summarizes some of the factors influencing mercury distribution in a gas cleaning system in the smelting environment.

**Table 6**

Some factors influencing the mercury distribution in a gas cleaning system (after (Holmström et al. 2012))

Gas characteristic	Consequence for mercury distribution
Presence of Se or $\text{S}^0$ or alternatively $\text{H}_2\text{S}_{(\text{g})}$	Formation of $\text{HgSe}$ or $\text{HgS}$ (particles) → recovered by bag filter and wet ESP
Very high load of elemental Hg into gas cooling system	Formation and condensation of liquid elemental Hg throughout the system
High gas temperature after gas cooling at a BN tower	Results in relatively high content $\text{Hg}^0$ after BN tower
Function of wet ESP	High efficiency is necessary; otherwise, Hg-rich particles will be transferred to acid
Presence of oxidized Hg in process gas at a bag filter	Will result in more Hg to bag filter dust

The gas purity requirements for the mercury removal processes are about the same as for the sulfuric acid plants. In the specific case of the Boliden-Norzinc (BN) process the mercury vapour pressures of the circulating liquids are sensitive to the temperature. For that reason, the entering gas temperature should be as low as possible. Normal requirements for the inlet gas to the mercury removal stage of the BN, thiosulfate and selenium filter processes are given in Table 7.

**Table 7**

Gas quality and properties required for the inlet gas to the mercury removal stage of BN, thiosulfate and selenium filter processes (industry data provided by Outotec)

Parameter	BN process	Thiosulfate process	Selenium filter
Dust	max. 1 mg/Nm <sup>3</sup>	max. 1 mg/Nm <sup>3</sup> (after wet ESP stage)	max. 10 mg/Nm <sup>3</sup>
Sulfuric acid mist	max. 20 mg/Nm <sup>3</sup>	max. 20 mg/Nm <sup>3</sup> (after wet ESP stage)	max. 20 mg/Nm <sup>3</sup>
Gas temperature	max. 40 °C	not critical	max. 90 °C

Outotec, the major distributor of mercury control technology for smelting has described an approach to the choice of technology (Holmström et al. 2012) in cases where more extensive removal of mercury from the gas is required. The three technologies described are the Boliden-Norzink process; the Se-filter for use in a static bed with relatively small gas flows; and an activated carbon filter for use in a static bed or injection of activated carbon upstream of a bag filter. According to Outotec, the choice (Holmström et al. 2012) is determined by the process conditions, and may be simply illustrated by the diagram presented in Figure 9.

This figure is meant as a guide to possible technology choice and may not be appropriate in many cases, for example where selenium is present in the concentrate. Such technology may not be necessary where a combination of gas cleaning equipment with sulfuric acid plants is operated and sufficiently controls mercury and also sulfur emissions.

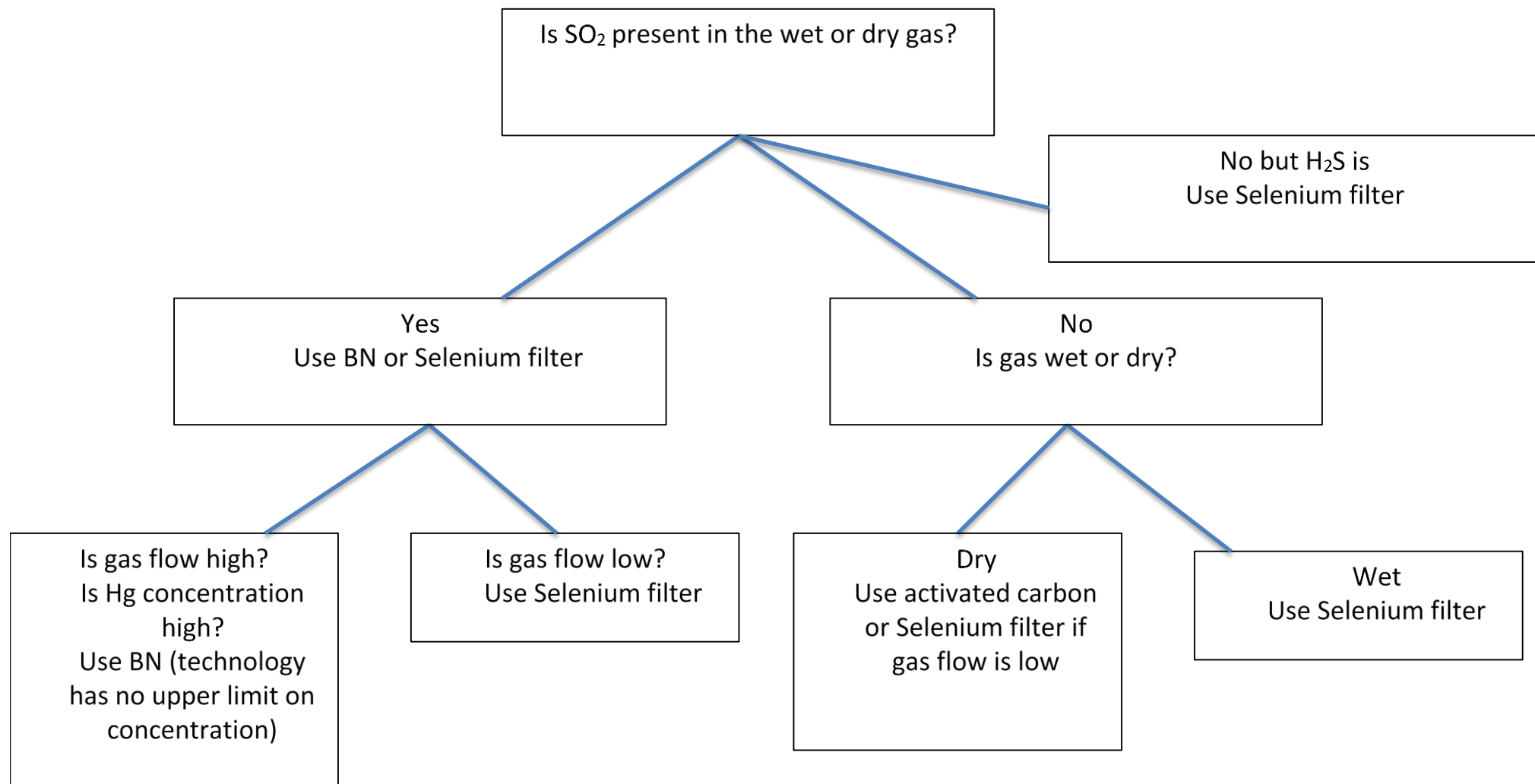

Figure 9: Mercury control considerations where high mercury removal is required and the choice includes the BN, selenium filter and activated carbon processes

## 5.2 Best environmental practices

This section describes general best environmental practices (BEP) to control, and where feasible, reduce, atmospheric mercury emissions from smelting and roasting processes used in the production of non-ferrous metals.

To develop and implement specific BEP, careful planning and commitment from all levels within a company are required. The development of BEP may be facilitated by considering applicable regulations, administrative controls and plant management practices.

### 5.2.1 Environmental management systems

An environmental management system is a structured approach to managing the environmental aspects of an operation that typically includes: reviewing the company's environmental goals; analysing its environmental risks, impacts and legal requirements; setting environmental objectives and targets to reduce environmental impacts and comply with legal requirements; establishing programmes to meet these objectives and targets; monitoring and measuring progress in achieving the objectives; ensuring employees' environmental awareness and competence; and reviewing progress of the system and continuously improving it. Recommendations for implementation may include:

- Developing and implementing preventative, predictive and corrective maintenance programmes to operate pollution abatement systems effectively;
- Maintaining production equipment to facilitate their normal operation and to minimize process upsets;
- Improving operational management, developing contingency plans, conducting regular training of the operators;
- Executing a spill prevention programme and implementing good housekeeping throughout the facility;
- Establishing a monitoring plan for mercury measurement in the relevant stages of the process;
- Developing and maintaining an overall record of mercury emissions at the relevant process and facility level.

### 5.2.2 Blending feedstocks to control mercury emissions

Blending is an operational process performed to produce a stable and homogeneous feed by mixing ores or concentrates of varying quality, combining the ores or concentrates with fluxes, or mixing in different secondary raw materials. Blending may be used to control mercury emissions when smelter feed materials have extremely variable or higher than desirable mercury concentrations. The treatment of a stable, homogenous feed facilitates steady-state operating conditions in which pollution controls can function more efficiently. In addition, lower overall mercury content in smelter feed would generate reduced mercury concentrations in the off-gas and decrease the mercury emissions to the final stack. In some specific cases the ore may also have very low mercury content, and no additional control measures may be required to achieve low emissions.

For sources that practice blending, the following considerations should be taken into account:

- Blending can be a very dusty operation and high levels of containment, particulate matter extraction and de-dusting should be used. Collected dusts should be returned to the process.
- Wet mixing may also be used to avoid the production of dusts. In some cases, a slurry is produced that is then dewatered and used in a pelletizing process.
- To achieve accurate blends, samples of each feed material should be taken beforehand to analyse the relevant metal content, including impurities such as mercury. Blends should be planned by combining appropriate ratios of feed materials based on these results. Blending plants, loss-in-weight dosing systems, belt scales, and the tracking of loaded volumes can all be used to achieve accurate blends.

### 5.2.3 Atmospheric mercury emissions

Control measures and strategies should be implemented to reduce the generation of mercury emissions. Care must be taken in designing gas cleaning units, including stacks, to suit local meteorological, topographic and site environmental conditions. Fugitive emissions from point sources which reasonably can be captured by hooding systems and appropriate enclosure of units should be so captured. Recommendations for implementation include:

- Optimizing process design to reduce off-gas emissions and pollutant content; design for continuous operation where technically and economically viable;
- Operating furnaces and reactors under negative pressure and applying appropriate gas cleaning techniques on the extracted gases;
- Sealing of furnaces and reactors, and retrofitting existing furnaces with maximum sealing;

- Conducting parametric monitoring to prevent flue gas condensation and pipeline corrosion due to excess humidity;
- Implementing a leak-detection programme and repairing leaks as necessary;
- Applying corrective action to any equipment which generates significant fugitive emissions.

#### **5.2.4 Particulate matter control**

Particulate matter (PM) controls are important because PM carries particle-bound mercury. PM control methods must be considered during the planning stage and emissions tracked. Plants should implement continuous improvement in PM controls during operation including:

- Identifying and regularly inspecting potential PM sources;
- Using dust extraction systems with appropriate particulate controls to remove particulates from working areas and buildings;
- Using negative pressure enclosure on PM-creating units to prevent overflow of particulate-bearing gases;
- Installing baghouse filters with more than one chamber to enable inspection and maintenance during operation;
- Maintaining the performance of the baghouse with regular inspection and bag replacement.

#### **5.2.5 Environmentally sound management and disposal of air pollution control wastes**

In order to prevent unnecessary emissions, plants should use the following approaches to achieve appropriate management and disposal of residues generated from air pollution control devices:

- Safe storage and transport of mercury wastes resulting from air pollution controls (e.g., liquid elemental mercury recovered from the retorts or mercury(I) chloride produced from the Boliden-Norzink process);
- Trade in mercury only in line with Article 3 of the Convention;
- Disposal of mercury wastes consistent with other relevant articles of the Convention.



## **6 Monitoring of mercury in smelting and refining processes used in the production of non-ferrous metals**

General and cross-cutting aspects of testing, monitoring and reporting are discussed in the introductory chapter of this document. Specific aspects of mercury emission monitoring inherent to non-ferrous metals processes will be discussed in the present section.

In the non-ferrous smelting and refining sector, input materials that may contain mercury include concentrates, fluxes and fuel. In addition to finished metals, the product streams may include metal powders, metal compounds, sulfuric acid and fertilizer. By-product streams could include slags, calomel (mercury(I) chloride,  $\text{Hg}_2\text{Cl}_2$ ), while waste streams may include slags, calomel, sludges and precipitates from pollution control equipment.

Mercury emissions can vary significantly within a single facility over time or among facilities conducting similar processes, because of the variable mercury content in the materials entering the process. Mercury concentrations can change rapidly in the concentrates, fuel or other inputs such as scrap metal. When conducting sampling, care must be taken, as far as possible, to ensure that the process is operating at a steady state representative of normal operating conditions, that mercury concentrations in the input streams are representative of normal feeds, and that fugitive emissions are minimized. If the operating conditions are not typical, extrapolation of the sampling data may provide results with a large margin of error.

Given the diversity of processes used within the non-ferrous metals smelting and refining sector, significant process variations can exist, even between facilities producing the same type of metal product. Site-specific characteristics should be taken into account when selecting the most appropriate monitoring method and planning for the sampling campaign. In addition to gathering data on mercury emissions, documentation of the metal production rate is also recommended to allow for the calculation of mercury emissions per ton of metal.

### **6.1 Direct measurement methods**

#### **6.1.1 Impinger sampling**

Impinger sampling with wet chemicals has been the traditional sampling method used to measure mercury concentrations in gas within the non-ferrous metals smelting and refining sector. Due to the complexity and cost of this method, impinger sampling is done less frequently, such as quarterly or annually. While this method typically provides reliable data for the sampling duration, the results may not be representative if mercury concentrations are variable over short time periods.

#### **6.1.2 Sorbent traps and sorbent trap monitoring systems**

In the non-ferrous metals smelting and refining sector, sorbent trap monitoring can be used effectively to provide data on mercury concentrations in exhaust gases over periods of time. While this method would not provide real-time results, the data obtained would indicate the operating performance over the previous set time period. With this feedback loop approach, adjustments to the process can then be made as needed.

Sorbent trap monitoring is effective in gas streams with low particulate matter concentrations. In a non-ferrous facility, the final stack is usually the appropriate location for installation of a sorbent trap monitoring system. At this stage, the cleaned stack gas should contain low levels of mercury, particulate matter and other pollutants.

#### **6.1.3 Continuous emissions monitoring systems**

Continuous emissions monitoring systems (CEMS) for mercury have not yet been widely used in the non-ferrous metals smelting and refining sector. CEMS have been commonly used for measuring low levels of mercury concentration in high exhaust flowrates, such as in the coal-fired power industry. In comparison, many non-ferrous smelting facilities emit more chemically complex exhaust gases with lower flowrates and higher levels of mercury concentration in more complex gas streams.

In facilities operating multiple stacks, it may be more appropriate to install the CEMS on the final stack to monitor releases to the environment. At that final stage in the process, the stack gas should have undergone cleaning processes where the majority of the air pollutants in the stack gas would have already been removed, such as through particulate matter controls, mercury removal, and acid production. The data collected would provide indicative, real-time trends on operating performance. If the quantity of mercury in the feed streams is known, mercury removal efficiency can be calculated using the CEM data.

## **6.2 Indirect measurement methods**

### **6.2.1 Mass balance**

While a mass balance would provide data for a specified time period, and not on a real-time basis, it may be useful as an indicative tool for the tracking of operating performance and mercury removal efficiency, provided the content of mercury in the feedstocks, products and other key streams is sufficient to allow a reliable calculation.

Normal operating practice at a non-ferrous metals smelting and refining facility should already include regular sampling and assaying (chemical analysis) of the metals content in the feedstocks, products and other key streams to ensure efficient process control. Inclusion of mercury as an analyte in these streams yields essential data to be used in the mass balance. Information on the chemical content of purchased fuel can be provided by the fuel supplier. Given that a smelter or refinery usually conducts in-house assay analysis of metals content in its main inputs and outputs on a daily basis, the facility should consider conducting its own mercury analyses at an incremental cost.

To calculate a facility's annual mercury emissions using a mass balance, the mercury concentrations and mass flowrates of all streams should be tracked and recorded over the course of an entire year, which requires a high degree of effort. In addition, all streams that can accumulate mercury should be tracked. Mercury mass data would be calculated by multiplying the mercury concentration by the stream mass flowrate and the time period (e.g., one year).

Owing to the inherent variability of mercury-mass flow rate measurements and mercury accumulation measurements, and multiple input and output flows, it may be difficult to come up with a definitive figure for the mass balance. For well-controlled processes where the mercury emission rate is only a fraction of the mercury feed rate, direct measurements of exhaust streams through sampling would be more appropriate than completing a mass balance.

### **6.2.2 Predictive emission monitoring systems**

Predictive emission monitoring systems (PEMS) may not be a reliable method of mercury emission monitoring within the non-ferrous metals smelting and refining sector. In this sector, mercury content in furnace feedstocks can change significantly over short periods, depending on the concentrates processed. Even in a facility processing concentrates from a dedicated mine, the mercury content can fluctuate substantially, depending on the location of mining within the ore body. As a result, the establishment of correlations between surrogate parameters and mercury emissions may not produce representative results. If PEMS are considered, thorough analysis should first be done to determine the uncertainty of the method on a case-by-case basis.

### **6.2.3 Emission factors**

For the non-ferrous smelting and refining sector, mercury emissions can vary significantly within a single facility over time or among facilities conducting similar processes, owing to the changing mercury content in the input streams. Accordingly, when using emission factors, the estimated emissions may contain a high margin of error. In particular, estimates using general published emission factors should be considered as a rough indication of emission levels. An alternative approach would be to develop site-specific emission factors based on actual sampling data and source activity information.

## 7 References

- UNEP (2008). Technical Background Report to the Global Atmospheric Mercury Assessment, Arctic Monitoring and Assessment Programme/UNEP Chemicals Branch, 159 pp.
- UNEP (2013). Technical Background Report for the Global Mercury Assessment 2013, Arctic Monitoring and Assessment Programme/UNEP Chemicals Branch, vi + 263 pp.
- BREF NFM (2014). Best Available Techniques Reference Document for the Non Ferrous Metals Industries (BREF NFM), available at: [http://eippcb.jrc.ec.europa.eu/reference/BREF/NFM\\_Final\\_Draft\\_10\\_2014.pdf](http://eippcb.jrc.ec.europa.eu/reference/BREF/NFM_Final_Draft_10_2014.pdf), IPTS, Joint Research Centre (JRC), European Commission, Seville, Spain, 1242 pp.
- Coleman, R.T.J. (1978). Emerging Technology in the Primary Copper Industry. Prepared for the U.S, EPA; data2.collectionscanada.ca/pdf/pdf001/p000001003.pdf; accessed on 7 April 2014, Habashi, F. (1978). Metallurgical plants: how mercury pollution is abated. *Environmental Science & Technology* 12, pp. 1372–1376.
- Holmström, Å., L. Hedström, A. Målsnes (2012). Gas Cleaning Technologies in Metal Smelters with Focus on Mercury. Sino-Swedish Cooperation on Capacity Building for Mercury Control and Management in China (2012–2013). Outotec.
- Hultbom, K. B. (2003). Industrially proven methods for mercury removal from gases. EPD congress, The Minerals, Metals & Materials Society (TMS).
- Krumins T. , C. Stunguris, L. Zunti and S Blaskovich (2013). Mercury removal from pressure oxidation vent gas at Newmont Mining Corporation's Twin Creek Facility. *Proceedings of Materials Science and Technology*. Montreal QC; The Minerals, Metals and Materials Society, 129-144
- Morgan, S. (1968). The Place of the Imperial Smelting Process in Non-ferrous Metallurgy.
- Reimers, J. H., et al. (1976). A review of Process Technology in Gases in the Nonferrous Metallurgical Industry for the Air Pollution Control Directorate, [nepis.epa.gov/Exe/ZyPURL.cgi?Dockey=91018I2W.txt](http://nepis.epa.gov/Exe/ZyPURL.cgi?Dockey=91018I2W.txt); accessed on 7 April 2014, Jan H. Reimers and Associates Limited, Metallurgical Consulting Engineers, Oakville, Ontario, Canada.
- Schulze, A. (2009). Hugo Petersen – Competence in gas cleaning systems downstream nonferrous metalurgical plants. The Southern African Institute of Mining and Metallurgy – Sulphur and Sulphuric Acid Conference 2009, pp. 59–76.
- Sundström, O. (1975). Mercury in Sulfuric Acid: Bolden Process Can Control Hg Levels during or after Manufacture. *Sulfur* No. 116, The British Sulfur Corp., January–February 1975: pp. 37–43.
- Takaoka, M., D. Hamaguchi, R. Shinmura, T. Sekiguchi, H. Tokuichi (2012). Removal of mercury and sulfuric acid production in ISP zinc smelting. International Conference on Mercury as a Global Pollutant, Abstract 16-PP-107.
- UNECE (2013). Guidance document on best available techniques for controlling emissions of heavy metals and their compounds from the source categories listed in annex II to the Protocol on Heavy Metals, UN Economic Commission for Europe: Executive Body for the Convention on Long-range Transboundary Air Pollution, 33 pp.

## Annex VI

### Waste incineration facilities

#### SUMMARY

Waste incineration facilities are identified in the Minamata Convention as one of the major industrial sources of mercury emissions. The category is listed in its Annex D.

The potential purposes of waste incineration include volume reduction, energy recovery, destruction or at least minimization of hazardous constituents, disinfection and the recovery of some residues.

To achieve best results for environmental protection as a whole, it is essential to coordinate the waste incineration process with upstream activities (e.g., waste management techniques) and downstream activities (e.g., disposal of solid residues from waste incineration).

When considering proposals to construct new waste incinerators, consideration should be given to alternatives such as activities to minimize the generation of waste, including resource recovery, reuse, recycling, and waste separation, and the promotion of products that contribute less or no mercury to waste streams. Consideration should also be given to approaches that prevent mercury entering waste which will be incinerated.

The environmentally sound design and operation of waste incinerators require the use of both best available techniques (BAT) and best environmental practices (BEP), which are to some extent overlapping, in order to prevent or minimize the emissions of harmful substances like mercury.

BEP for waste incineration include appropriate off-site procedures, such as overall waste management and consideration of the environmental impacts of siting, and on-site procedures, such as waste inspection, proper waste handling, incinerator operation, management practices and the handling of residues.

BAT for waste incineration include the appropriate site selection, waste input and control, and techniques for combustion, flue gas, solid residue and effluent treatment. BAT for controlling mercury emissions from waste incineration facilities may be considered to be high efficiency scrubbers with ingredients in the scrubber liquor; scrubber with injection of bromine containing chemicals into the combustion chamber; or activated carbon injection with FF. In the event of high mercury levels in the raw gas, a combination of the above techniques can be applied.

Releases of mercury from municipal solid waste incinerators designed and operated according with BAT and BEP considerations in mind occur mainly via fly ash, bottom ash and filter cake from wastewater treatment. Accordingly, it is of major importance to provide for a safe sink of these waste types, for example, through their pretreatment and final disposal in dedicated landfills, which are designed and operated according to BAT.

With a suitable combination of primary and secondary measures mentioned in this chapter, mercury emissions into the air not higher than 1–10  $\mu\text{g}/\text{m}^3$  (at 11 per cent  $\text{O}_2$ ) are associated with BAT. It is further noted that, under normal operating conditions, emissions lower than this level can be achieved with a well-designed waste incineration plant.

## Contents

<b>1</b>	<b>Introduction .....</b>	<b>103</b>
<b>2</b>	<b>Processes used in waste incineration facilities, including consideration of input materials and behaviour of mercury in the process.....</b>	<b>104</b>
<b>2.1</b>	<b>General description of wastes that could result in emissions of mercury or mercury compounds when incinerated .....</b>	<b>104</b>
2.1.1	Waste hierarchy .....	104
2.1.2	Introduction to different types of waste with regard to mercury emissions from waste incinerator facilities .....	104
<b>2.2</b>	<b>Incineration process .....</b>	<b>106</b>
2.2.1	Introduction to general incineration technique .....	106
2.2.2	Pretreatment of waste for incineration.....	107
2.2.3	Description of incinerator types .....	108
2.2.4	Incineration of specific waste streams.....	111
<b>3</b>	<b>Emission control techniques .....</b>	<b>115</b>
<b>3.1</b>	<b>Dust (particulate matter) removal techniques .....</b>	<b>115</b>
<b>3.2</b>	<b>Wet scrubbing techniques.....</b>	<b>115</b>
<b>3.3</b>	<b>Activated carbon injection.....</b>	<b>116</b>
<b>3.4</b>	<b>Boiler bromide addition .....</b>	<b>118</b>
<b>3.5</b>	<b>Static bed filters .....</b>	<b>118</b>
<b>3.6</b>	<b>Illustrative examples for emission values achieved with the techniques described above. ....</b>	<b>119</b>
<b>3.7</b>	<b>Use and disposal of solid residues from incineration.....</b>	<b>121</b>
3.7.1	Treatment of solid flue gas residues .....	121
3.7.2	Stabilization and solidification .....	121
3.7.3	Bottom and fly ash use .....	122
3.7.4	Final disposal of residues .....	122
<b>3.8</b>	<b>Alternative treatment techniques for waste streams that can generate emission of mercury and mercury compounds when incinerated .....</b>	<b>122</b>
<b>4</b>	<b>Emerging techniques .....</b>	<b>124</b>
<b>4.1</b>	<b>High efficiency activated carbon adsorber .....</b>	<b>124</b>
<b>4.2</b>	<b>Coconut char as an alternative to coal-based activated carbon .....</b>	<b>125</b>
<b>5</b>	<b>BAT and BEP for waste incineration facilities .....</b>	<b>126</b>
<b>5.1</b>	<b>Introduction to BAT for the incineration of waste .....</b>	<b>126</b>
<b>5.2</b>	<b>Pretreatment of waste before incineration .....</b>	<b>126</b>
<b>5.3</b>	<b>BAT for waste input and control.....</b>	<b>126</b>
<b>5.4</b>	<b>BAT for waste incineration.....</b>	<b>126</b>
5.4.1	General conditions for combustion techniques.....	126
5.4.2	Municipal solid waste incineration techniques.....	127
5.4.3	Hazardous waste incineration techniques.....	127
5.4.4	Sewage sludge incineration techniques .....	127
5.4.5	Medical waste incineration.....	128
<b>5.5</b>	<b>BAT for flue-gas treatment.....</b>	<b>128</b>

5.5.1	Upgrading and improvement of existing treatment techniques .....	129
5.5.2	Performance levels associated with the use of BAT.....	129
<b>5.6</b>	<b>Introduction to BEP .....</b>	<b>129</b>
5.6.1	Waste management practices .....	130
5.6.2	Prevention of fire risks .....	133
<b>6</b>	<b>Mercury monitoring techniques.....</b>	<b>134</b>
<b>6.1</b>	<b>Direct methods.....</b>	<b>134</b>
<b>6.2</b>	<b>Indirect methods.....</b>	<b>135</b>
<b>6.3</b>	<b>Most appropriate techniques for monitoring in the waste incineration sector .....</b>	<b>135</b>
<b>7</b>	<b>References .....</b>	<b>137</b>

## 1 Introduction

This section is concerned only with the dedicated incineration of wastes and not other situations where waste is thermally treated, for example, co-incineration processes such as cement kilns and large combustion plants, which are dealt with in the sections relating to those processes.

Open burning is the burning of any type of waste in the open air or in open dumps, and in incineration devices range from so-called “drum incinerators” and locally constructed incinerators with no pollution control to small ovens used for the burning of medical waste that do not allow for complete combustion. Open burning of waste mercury and mercury-added products contributes significantly to releases of mercury from products.

Accordingly, open burning is considered “bad environmental practice” and should be discouraged as it can lead to emissions of toxic substances into the environment. The practices of open burning and burning in simply constructed incineration devices are not covered further in this guidance.

Mercury is volatilized in the incineration process and, therefore, specific action should be taken both before, during and after incineration to reduce these emissions. The only relevant primary techniques for preventing emissions of mercury into the air before incinerating are those that prevent or control, if possible, the inclusion of mercury in waste.

For existing incinerators, parties shall implement one or more of the measures listed in paragraph 5 of Article 8 of the Convention. The party may apply the same measures to all relevant existing sources, or may adopt different measures in respect of different source categories. The objective for the measures applied by a party shall be to achieve reasonable progress in reducing emissions over time. This can include the use of best available techniques and best environmental practices, a multi-pollutant control strategy that would deliver co-benefits for control emissions or other possible measures, the objective being to achieve reasonable progress in reducing emissions over time.

For new incinerators, however, where construction or substantial modification starts at least one year after the date of the Convention’s entry into force for the party, parties shall be required to use best available techniques and best environmental practice to control and, where feasible, reduce emissions.

## 2 Processes used in waste incineration facilities, including consideration of input materials and behaviour of mercury in the process

### 2.1 General description of wastes that could result in emissions of mercury or mercury compounds when incinerated

#### 2.1.1 Waste hierarchy

The hierarchy captures the progression of a material or product through successive stages of waste management, and represents the latter part of the life-cycle for each product. The primary aim of the waste hierarchy is to extract the maximum practical benefits from materials and to generate the minimum amount of waste. The proper application of the waste hierarchy can have several benefits: it can help prevent emissions of mercury from waste materials that may contain mercury or are contaminated with mercury, reduce greenhouse gas production, reduce other air pollutants, save energy, conserve resources, create jobs and stimulate the development of green technologies. The waste hierarchy is divided into the following stages:

- **Prevention:** The prevention of waste is the most vital point in the waste hierarchy. Prevention or reduction minimizes the generation of waste products in the first place. Prevention usually results in the lowest environmental and economic life-cycle costs because it does not require collecting or processing of materials. Typically, prevention also produces significant benefits in terms of production efficiencies and the use of resources. It involves using less material in design and manufacture, trying to keep products for longer, and using less hazardous materials.
- **Reuse:** The direct reuse of alternative uses of materials from the waste stream is the next most desirable option. It is any operation where products or materials that are not waste are used again for the same purpose for which they were intended. Reusing materials from the waste stream often requires collection with relatively little or no processing. It involves checking, cleaning, repairing and refurbishing entire items or spare parts. Materials contaminated with mercury should not be reused.
- **Recycle:** Recycling of waste is the next priority. It applies to any activity that includes the collection of used, reused, or unused items that would otherwise be considered waste. Recycling involves sorting and processing the recyclable products into raw material and then remanufacturing the recycled raw materials into new products.
- **Recovery:** The recovery of waste is further separated into categories: the recovery of materials and the recovery of energy. The preferred option is that which is better for the environment and human health. The recovery of materials is most often preferred and includes activities such as recycling and composting. These management activities generally require a collection system and a method of material processing and conversion into a new product. Recovery of energy, such as incineration, is usually the less popular option. The conversion of non-recyclable waste materials into usable heat, electricity, or fuel is accomplished through a variety of processes, including anaerobic digestion, gasification and pyrolysis.
- **Disposal:** The last resort is disposal and this is only considered once all other possibilities have been explored. Disposal is any operation that involves the dumping and incineration of waste without energy recovery. Before final disposal, pretreatment may be necessary, depending on the nature of the waste. Landfilling is the most common form of waste disposal and the final disposal option.

#### 2.1.2 Introduction to different types of waste with regard to mercury emissions from waste incinerator facilities

##### 2.1.2.1 Municipal waste

Municipal solid waste, more commonly known as trash or garbage and sometimes abbreviated as MSW, consists of everyday items that are used and then throw away, such as product packaging, grass clippings, furniture, clothing, bottles, food scraps, newspapers, appliances, paint, batteries and countless others. These come from households, schools, hospitals, businesses and other establishments. The municipal solid waste industry can be divided into four components, namely: recycling, composting, landfilling, and waste-to-energy via incineration. The primary steps in the waste cycle are generation, collection, sorting and separation, transfer, and disposal. A number of municipal wastes contain hazardous substances, along with organic chemicals such as pesticides. Traditional medicines, cosmetics and other items may also contain hazardous substances.

The sources of mercury in municipal solid waste include the following: household batteries, electric lighting, paint residues, thermometers, thermostats, pigments, dental uses, special paper coating, mercury light switches, film pack batteries and others. Typical mercury concentrations in municipal solid waste range from 0.15 to 2 mg/kg (Muenhor et al. 2009).



### 2.1.2.2 Hazardous waste

Hazardous waste is a waste that has the potential to adversely affect human health and the environment, and therefore must be managed in an environmentally sound manner. Hazardous wastes can be liquids, solids, gases, or sludges. They can be discarded in commercial products, such as cleaning fluids or pesticides, or the by-products of manufacturing processes. Chapter II of the Technical Guidelines of the Basel Convention can provide further guidance and information on wastes considered hazardous, in addition to the scope of mercury waste covered under that Convention (Basel Convention, 2015).

### 2.1.2.3 Waste from electrical and electronic equipment

Electrical and electronic equipment may contain mercury along with other materials that are hazardous. Often, electrical and electronic waste is collected separately, and is not usually incinerated but is the subject of recovery and recycling processes – these processes to recover materials are not the subject of this guidance. Electrical and electronic equipment may be collected together with municipal waste. Such equipment, if known to contain mercury and entering the waste stream, should be dealt with in accordance with Article 11 of the Minamata Convention. Sometimes, however, electrical and electronic equipment is incinerated along with municipal waste, and can contribute to mercury emissions.

### 2.1.2.4 Medical waste containing mercury or contaminated with mercury

Medical waste is generally defined as any solid waste that is generated in the diagnosis, treatment, or immunization of human beings or animals, in research pertaining thereto, or in the production or testing of biological materials. The World Health Organization (WHO) classifies medical waste in the following categories: sharps, infectious, pathological, radioactive, pharmaceutical and others (often sanitary waste produced at hospitals) (WHO, 2014, p. 4). The specific categories in which medical waste is classified may vary in different countries (e.g., sharps are not classified as hazardous waste in all countries). As a general rule, between 75 and 90 per cent of the waste produced by health-care facilities is non-risk (non-infectious, non-hazardous) general waste, comparable to municipal waste. Only a small proportion of health-care waste is regarded as hazardous, and may create health risk (Emmanuel, 2012).

Hazardous medical waste has the possibility to affect humans in non-infectious ways. This type of waste includes sharps, which are generally defined as objects that can puncture or lacerate the skin, and can include needles and syringes, discarded surgical instruments such as scalpels and lancets, culture dishes and other glassware. Hazardous medical waste can also include chemicals. Some hazardous waste can also be considered infectious waste, depending on its usage and exposure to human or animal tissue prior to discard. Old pharmaceuticals are sometimes hazardous, and may contain mercury.

Mercury is used in a variety of ways specific to the medical sector, which include:

- Mercury in measuring devices: Mercury is contained in many common medical measuring devices such as sphygmomanometers (blood pressure devices), thermometers (specifically body temperature thermometers but also others) and a number of gastro-intestinal devices, such as cantor tubes, esophageal dilators (bougie tubes), feeding tubes and Miller Abbott tubes. As in other types of instruments, mercury has traditionally been used in these devices because of its unique physical properties, including the ability to provide highly precise measurements.
- Mercury in some types of traditional medicines: Some traditional medicines may contain mercury, although a number of regulatory authorities have introduced controls.
- Mercury in dental amalgams: Dental amalgam, sometimes referred to as “silver filling,” is a silver-coloured material used to fill teeth that have cavities. Dental amalgam is made of two nearly equal parts: liquid mercury and a powder containing silver, tin, copper, zinc and other metals. Amalgam has been one of the most commonly used tooth fillings. If the dental amalgam is incinerated, mercury may be emitted to the air from the incinerator stacks.
- Mercury compounds in certain preservatives, fixatives and reagents used in hospital: Some mercury compounds are used as preservatives in medicines and other products including vaccines.

### 2.1.2.5 Sewage sludge

Sewage sludge is a direct by-product of the treatment of domestic sewage at a wastewater treatment facility. Dental amalgam can contribute to the mercury load of sewage sludge if the amalgam waste is put into the wastewater stream, rather than being separated out. Owing to the physical-chemical processes involved in the treatment, the sewage sludge tends to concentrate heavy metals such as mercury, cadmium, lead and others and poorly biodegradable trace organic compounds, together with potentially pathogenic organisms (viruses, bacteria, etc.) present in wastewater. Typical levels of mercury in sewage sludge range between 0.6 and 56 mg/kg dry sludge (Hisau; Lo, 1998). Concentrations ranging from 1 to 4 mg/kg dry matter have also been reported, however (Werther; Saenger 2000).

### **2.1.2.6 Scrap wood**

Scrap wood is generated at residential and commercial wood frame construction sites, and may include such items as window frames painted with mercury-containing paint. Demolition operations usually generate wood waste which, as a result of its non-uniform nature, compounded by commingling with other materials, is not always reusable. If not contaminated with hazardous substances such as mercury (e.g., window frames painted with mercury-containing paint) the wood can still be reused, for example for wood panels. Contaminated wood may either be burned in an incineration plant or disposed of in a designated landfill site.

### **2.1.2.7 Common industrial waste**

Sometimes industrial waste containing, or contaminated with mercury, e.g., paints, solvents, petrochemicals, spent activated carbon, is incinerated along with municipal waste and can contribute to emissions of mercury and other hazardous substances.

## **2.2 Incineration process**

### **2.2.1 Introduction to general incineration technique**

Incineration is used as a treatment for a very wide range of wastes. Incineration itself is commonly only one part of a complex waste treatment system that altogether provides for the overall management of the broad range of wastes that arise in society. The objective of waste incineration is to treat wastes in such a manner as to reduce their volume and hazard, while capturing (and thus concentrating) or destroying potentially harmful substances that are, or may be, released during incineration. Incineration processes can also facilitate recovery of the energy, mineral or chemical content from waste.

Incinerators come in a variety of furnace types and sizes and combinations of pre-combustion and post-combustion treatment. There is also considerable overlap among the designs of choice for municipal solid waste, hazardous waste and sewage sludge incineration.

Incinerators are usually designed for full oxidative combustion over a general temperature range of 850 °C–1,200 °C. This may include temperatures at which calcinations and melting also occur. Gasification and pyrolysis represent alternative thermal treatments that restrict the amount of primary combustion air necessary to convert waste into process gas, which may be used as a chemical feedstock or incinerated with energy recovery. Compared to incineration, however, these systems are used relatively infrequently and operational difficulties have been reported at some installations. Waste incinerator installations may be characterized by the following functions: waste delivery, storage, pretreatment, incineration and energy recovery, flue gas cleaning, solid residue management, and wastewater treatment. The nature of the input waste will have a significant bearing on how each component is designed and operated.

Waste is generally a highly heterogeneous material, consisting essentially of organic substances, minerals, metals and water. During incineration, flue gases are created that will contain the majority of the available fuel energy as heat. In fully oxidative incineration the main constituents of the flue gas are water vapour, nitrogen, carbon dioxide and oxygen. Depending on the composition of the material incinerated, operating conditions and the flue gas cleaning system installed, acid gases (sulfur oxides, nitrogen oxides, hydrogen chloride), particulate matter (including particle-bound metals), and volatile metals, along with a wide range of volatile organic compounds, are emitted. Incineration of municipal solid waste and hazardous waste has also been shown to be a major potential emitter of mercury. Emissions can be substantially high when the input from possible sources (waste containing mercury, e.g., in products, treated waste wood) is not controlled or removed before incineration. It should be noted that mercury is present in elemental, oxidized and particulate forms in the flue gas. Mercury present in oxidized form – predominantly as mercury (II) chloride in incinerator flue gases – is generally easier to remove than elemental mercury.

Depending on the combustion temperatures during the main stages of incineration, volatile metals and inorganic compounds (e.g., salts) are totally or partly evaporated. These substances are transferred from the input waste to both the flue gas and the fly ash it contains. A residue fly ash (dust) and heavier solid ash (bottom ash) are created. The proportions of solid residue vary greatly according to the waste type and detailed process design. Other releases are residues from flue gas treatment and polishing, filter cake from wastewater treatment, salts and releases of substances into wastewater. It is therefore of major importance to provide for a safe sink of these waste types containing mercury. (see section 3.7). Figure 1 presents a simplified flow scheme of an incinerator.

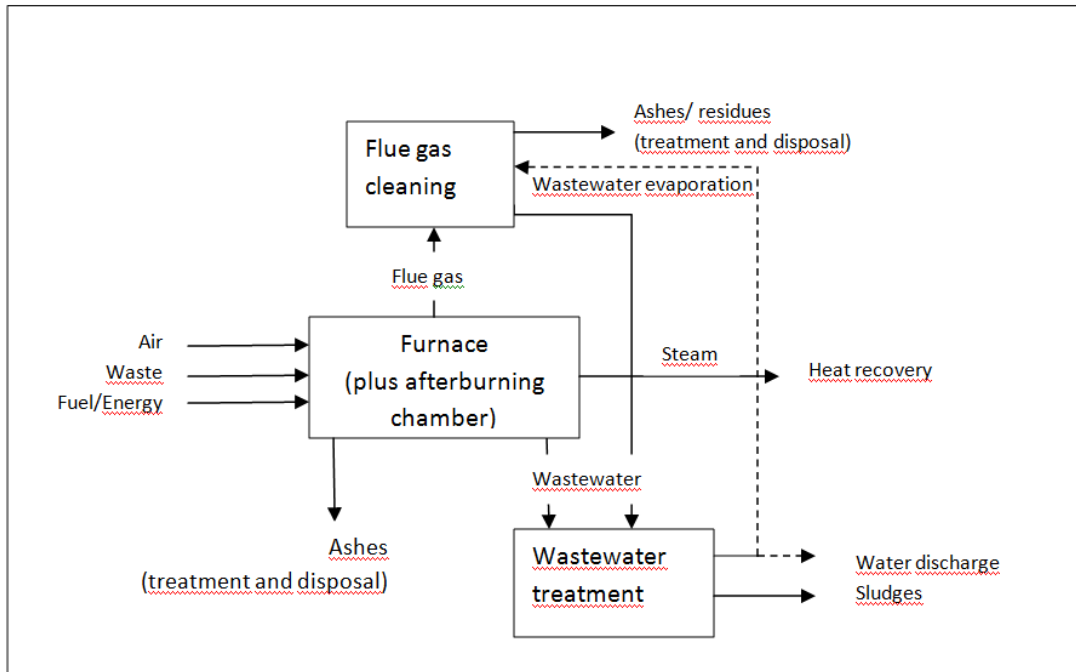

**Figure 1** Simplified flow scheme of an incinerator

### 2.2.2 Pretreatment of waste for incineration

#### Mixing of waste

Techniques used for mixing may include:

- Mixing of liquid hazardous wastes to meet input requirements for the installation
- Mixing of wastes in a bunker using a grab or other machine

Mixing of waste may serve the purpose of improving feeding and combustion behaviour and can help to avoid high mercury concentrations in the burned waste. Mixing of hazardous waste clearly involves risks and the mixing of different waste types should be carried out according to a recipe. In bunkers, wastes are mixed using bunker cranes in the storage bunker itself. Crane operators can identify potentially problematic loads (e.g., baled wastes, discrete items that cannot be mixed or will cause loading and feeding problems) and ensure that these are removed, shredded or directly blended (as appropriate) with other wastes. It is difficult for the crane operators themselves to identify mercury-containing waste.

#### Shredding of mixed municipal wastes

Untreated mixed municipal waste can be roughly shredded by passing delivered waste through crocodile shears, shredders, mills, rotor shears or crushers. The homogeneity of the waste is improved by shredding, resulting in more even combustion and reduction and more stable emissions from the furnace. Ensuring that the raw gas composition is more even will enable closer optimization of the flue-gas cleaning process. Many wastes contain appreciable quantities of ferrous and non-ferrous metals. These can be an inherent part of the waste itself (e.g., food and drink containers in municipal solid waste) or arise from the packaging of waste in drums (e.g., hazardous wastes) or other metal containers.

When the incoming wastes are shredded, metals can be removed before incineration to allow recycling. Metal separation can be achieved by using:

- Over-band magnets for large ferrous materials, such as shredded drums;
- Drum magnets for small and heavy ferrous items such as batteries, nails, coins, etc.,
- Eddy current separators for non-ferrous metals – mainly copper and aluminium used for packaging and electrical components.

## Shredding of drummed and packaged hazardous wastes

Liquid packaged waste and packed or bulk solid waste may be pretreated to produce a mixture for continuous feed to the furnace. Suitable wastes may be treated to a pumpable state for pumped injection to the kiln or shredded for adding to the storage burner, in process where solids and liquids separate and are then fed to the kiln separately using grabs and pumping respectively.

Pallets containing packaged liquid wastes of low to medium-high viscosity are shredded to between 5 and 10 cm. The shredded waste may then be screened before being transferred to tanks. Plastics that are screened out may be used as an energy source for incineration and ferrous metals can be removed for recycling with the use of magnets. In other cases wastes such as waste oils are not screened, and instead are pumped as a mixture of liquids and shredded solids to the kiln with thinning liquids (European Commission, 2006, Waste Incineration)

### 2.2.3 Description of incinerator types

The following sections describe continuous incineration processes. It is acknowledged that batch incineration processes are sometimes used; these, however, are usually associated with high emissions during start-up and shutdown and are not considered further in this chapter.

#### 2.2.3.1 Rotary kiln incinerator

For the incineration of hazardous waste which includes many types of medical waste rotary kilns are most commonly used (figure 2), but grate incinerators (including co-firing with other wastes) are also sometimes applied to solid wastes, and fluidized bed incinerators to some pretreated materials. Static furnaces are also widely applied at on-site facilities at chemical plants.

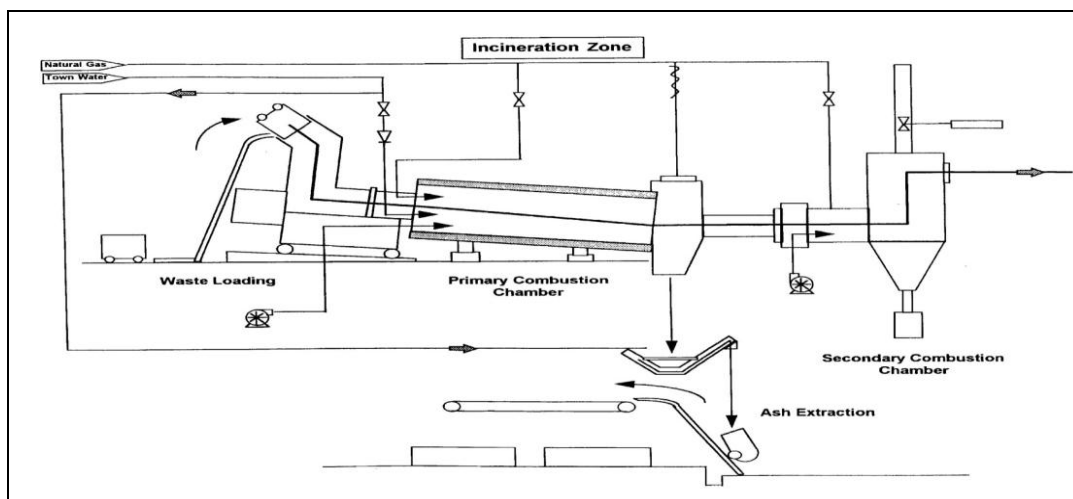

**Figure 2 Rotary kiln incineration system (www.hitemptech.com)**

Given the hazardous (and often uncertain) composition of the incoming waste streams, greater emphasis is placed on acceptance criteria, storage, handling and pretreatment than with municipal solid waste. For low-energy-value wastes, auxiliary fuels may be required.

In a rotary kiln solid, sludge, containerized or pumpable waste is introduced at the upper end of the inclined drum. Temperatures in the kiln usually range between 850 °C (500 °C when used as a gasifier) and 1,200 °C (as a high-temperature ash-melting kiln). The slow rotation of the drum allows a residence time of 30–90 minutes. The secondary combustion chamber following the kiln allows the oxidation of the combustion gases. Liquid wastes or auxiliary fuels may be injected here along with secondary air to maintain a minimum residence time of two seconds and temperatures in the range of 850 °C–1,100 °C, effectively breaking down most remaining organic compounds. Requirements for combustion conditions may be prescribed, as in European Union Directive 2010/75/EU on the incineration of waste. Rotary kilns and afterburning chambers are in most cases constructed as adiabatic, ceramic-lined combustion chambers. After the combustion chamber flue gases pass through a void zone until a temperature of about 700 °C is reached. Subsequently, heating bundles such as evaporators, super-heaters and feed water preheaters are arranged. The waste heat boiler and energy supply system is comparable to that of grate firing systems. Incinerator capacities range between 0.5 and 3 tons per hour (for health-care waste incineration).

### 2.2.3.2 Liquid injection incinerators

Liquid injection incinerators, like rotary kiln incinerators, are commonly used for hazardous waste incineration. Liquid injection incinerators can be used to dispose of virtually any combustible liquid or liquid-like waste (e.g., liquids, slurries, and sludges). Typical liquid injection incinerator systems, which are possibly the simplest type of combustion device, include a waste burner system, an auxiliary fuel system, an air supply system, a combustion chamber, and an air pollution control system, as illustrated in

3. Liquid wastes are fed and atomized into the combustion chamber through the waste burner nozzles. These nozzles atomize the waste and mix it with combustion air. Atomization is usually achieved either by mechanical methods such as a rotary cup or pressure atomization systems, or by twin-fluid nozzles which use high-pressure air or steam. With a relatively large surface area, the atomized particles vaporize quickly, forming a highly combustible mix of waste fumes and combustion air. Typical combustion chamber residence time and temperature ranges are between 0.5 and 2 seconds, and 700 °C and 1,600 °C, respectively, in order to ensure complete liquid waste combustion. Liquid waste feed rates can exceed 2,000 l/hr. If the energy content of the waste is not high enough to maintain adequate ignition and incineration temperatures, a supplemental fuel such as fuel oil or natural gas is provided. In some cases, wastes with high solids are filtered prior to incineration to avoid nozzle plugging (US EPA 2005).

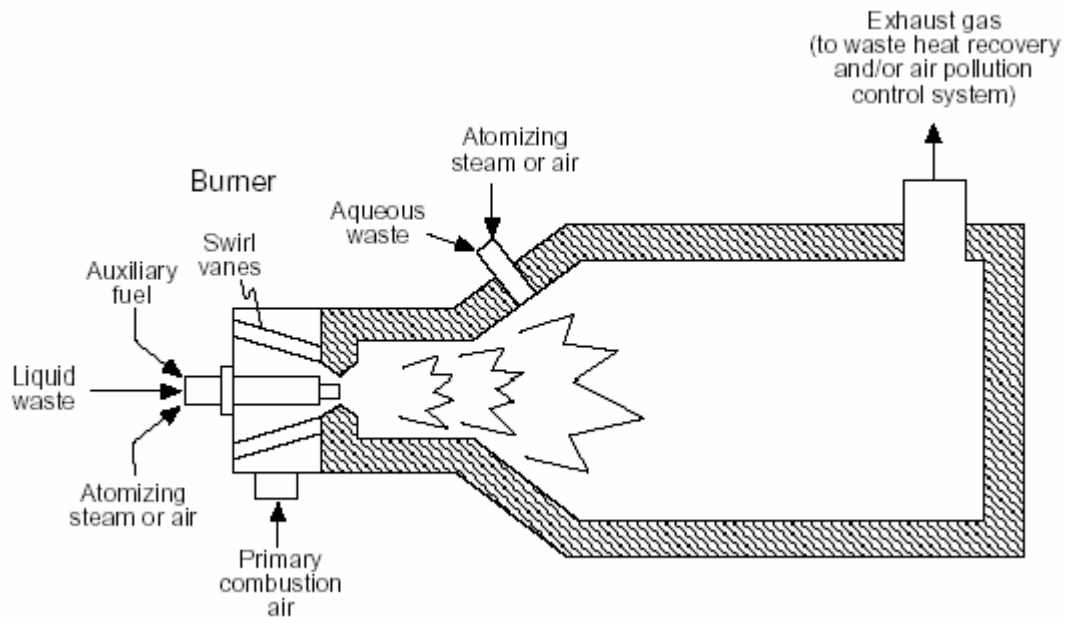
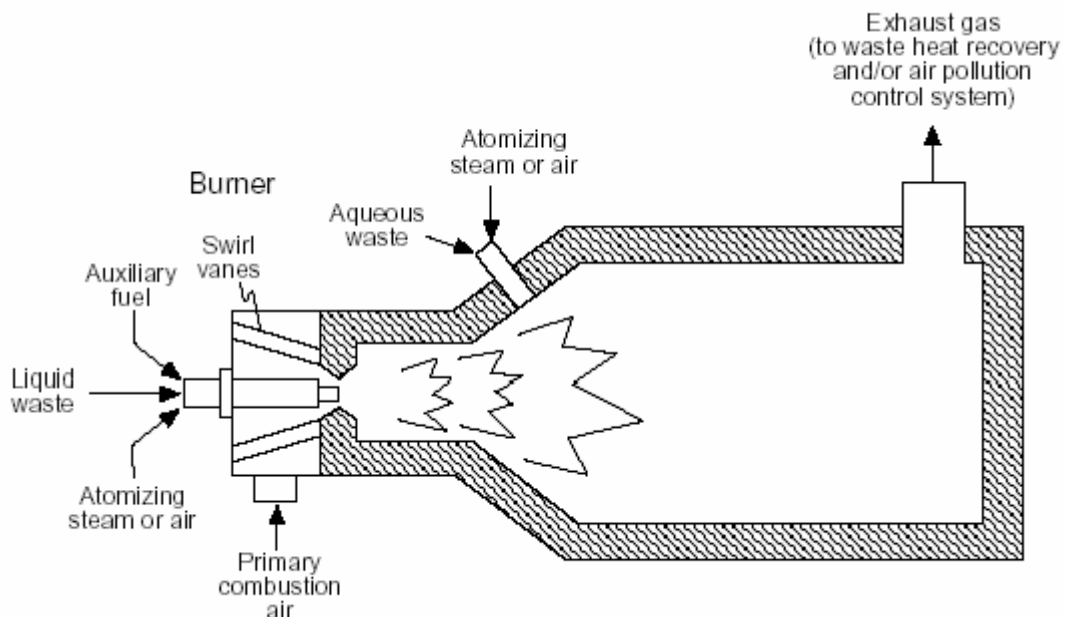

Figure 3 Typical liquid injection incinerator



## Grate incinerator

There are different types of grate incinerators, namely: moving and fixed grates.

### *Moving grate incinerators*

The typical incineration plant for municipal solid waste is a moving grate incinerator. Here the waste moves through the combustion chamber and this movement makes possible a more efficient and complete combustion.

The units can be designed with a range of capacities. One example is a single moving grate boiler which can handle up to 35 tons of waste per hour, and can operate for 8,000 hours per year with only one scheduled stop for inspection and maintenance of about one month's duration. The waste is introduced by a waste crane through the so-called "throat" at one end of the grate, from where it moves down over the descending grate to the ash pit in the other end. Here the ash is removed through a water lock. Part of the combustion air (primary combustion air) is supplied through the grate from below.

This air flow also has the purpose of cooling the grate itself. Cooling is important for the mechanical strength of the grate, and many moving grates are also water-cooled internally. Secondary combustion air is supplied into the boiler at high speed through nozzles over the grate. It facilitates complete combustion of the flue gases by introducing turbulence for better mixing and by ensuring a surplus of oxygen. In multiple or stepped hearth incinerators, the secondary combustion air is introduced in a separate chamber downstream the primary combustion chamber.

In European Union countries (European Commission, 2000), incineration plants must be designed to ensure that the flue gases reach a temperature of at least 850 °C for two seconds in order to ensure proper breakdown of toxic organic substances. In order to comply with this requirement at all times, backup auxiliary burners (often fuelled by oil) must be installed, and these are fired into the boiler in the event that the heating value of the waste becomes too low to reach this temperature alone. The flue gases are then cooled in the super-heaters, where the heat is transferred to steam, heating the steam typically to 400 °C at a pressure of 4,000 kPa for the electricity generation in the turbine.

At this point, the flue gas is at around 200 °C and is passed to the flue gas cleaning system. Often, incineration plants consist of several separate boiler lines (boilers and flue gas treatment plants), so that waste can continue to be received at one boiler line while the others are undergoing maintenance, repair, or upgrading.

### *Fixed grate*

The older and simpler kind of incinerator was a brick-lined cell with a fixed metal grate over a lower ash pit, with one opening in the top or side for loading and another opening in the side for removing incombustible solids, called clinker. Many small incinerators formerly found in apartment houses have now been replaced by waste compactors.

### **2.2.3.3 Fluidized bed incinerator**

Fluidized bed incinerators are widely used for the incineration of finely divided wastes such as refuse-derived fuel and sewage sludge. The method has been used for decades, mainly for the combustion of homogeneous fuels. The fluidized bed incinerator is a lined combustion chamber in the form of a vertical cylinder. In the lower section, a bed of inert material (e.g., sand or ash) on a grate or distribution plate is fluidized with air. The waste for incineration is continuously fed into the fluidized sand bed from the top or side. Preheated air is introduced into the combustion chamber via openings in the bed plate, forming a fluidized bed with the sand contained in the combustion chamber.

The waste is then fed to the reactor via a pump, a star feeder or a screw-tube conveyor. Drying, volatilization, ignition and combustion take place in the fluidized bed. The temperature in the free space above the bed (the freeboard) is generally between 850 °C and 950 °C. Above the fluidized bed material, the freeboard is designed to allow retention of the gases in a combustion zone. In the bed itself the temperature is lower, and may be around 650 °C.

Because of the well-mixed nature of the reactor, fluidized bed incineration systems generally have a uniform distribution of temperatures and oxygen, which results in stable operation. For heterogeneous wastes, fluidized bed combustion requires a preparatory process step for the waste so that it conforms to size specifications. For some waste this may be achieved by a combination of selective collection of wastes or pretreatment, such as shredding. Some types of fluidized beds (for example, the rotating fluidized bed) can receive larger particle size wastes than others. Where this is the case the waste may only require a rough size reduction or none at all.

### **2.2.3.4 Modular systems**

Modular systems are a general type of municipal solid waste incinerator used widely in the United States of America, Europe and Asia. Modular incinerators consist of two vertically mounted combustion chambers (a primary and secondary chamber). In modular configurations combustion, capacity typically ranges from 1 to 270 tons per day. There are two major types of modular systems, excess air and starved air.

The modular excess air system consists of a primary and a secondary combustion chamber, both of which operate with air levels in excess of stoichiometric requirements (i.e., 100–250 per cent excess air). In the starved (or controlled) air type of modular system, air is supplied to the primary chamber at sub-stoichiometric levels. The products of incomplete combustion entrain in the combustion gases that are formed in the primary combustion chamber and then pass into a secondary combustion chamber. Excess air is added to the secondary chamber, and combustion is completed by elevated temperatures sustained with auxiliary fuel (usually natural gas). The high, uniform temperature of the secondary chamber, combined with the turbulent mixing of the combustion gases, favours low levels of particulate matter and organic contaminants being formed and emitted.

## 2.2.4 Incineration of specific waste streams

### 2.2.4.1 Municipal waste incineration

Although in many areas landfilling of non-recycled waste remains the principal means for the disposal of municipal solid waste incineration and the subsequent landfilling of residues has become a common practice in many developed and industrializing countries.

Municipal solid waste incineration is commonly accompanied by the recovery of some calorific energy (“waste to energy”) in the form of steam and/or the generation of electricity. Incinerators can also be designed to accommodate processed forms of municipal solid waste-derived fuels, as well as co-firing with fossil fuels. Municipal waste incinerators can range in size from small package units processing single batches of only a few tons per day to very large units with continuous daily feed capacities in excess of a thousand tons.

The primary benefits of municipal solid waste incineration are the destruction of organic (including toxic) materials, the reduction in the volume of the waste and the concentration of pollutants (e.g., heavy metals) into comparatively small quantities of ashes, thus generating safe sinks if properly disposed of. The recovered energy can be an important additional benefit.

#### 2.2.4.1.1 Operational considerations for municipal solid waste incinerators

In many municipal solid waste incinerators, other waste fractions such as bulky waste, (e.g., from sorting plants), sewage sludge, medical waste or the high calorific fraction from waste pretreatment (e.g., from shredder plants) are also incinerated. These wastes have to be carefully evaluated prior to incineration to ascertain whether the waste incineration plant (including flue gas treatment, wastewater and residue treatment) is designed to handle these types of waste and whether it can do so without risk of harm to human health or the environment. Some important parameters are chlorine, bromine and sulfur content, heavy metals content, calorific content (lower heat value) and burnout behaviour.

High concentration of bromine may lead to the formation of brominated compounds such as polybrominated Dibenzo-p-Dioxins (PBDD) and polybrominated di-benzo furans (PBDF) (CSTEE, 2002).

Mercury is volatilized in the incineration process and therefore particular actions should be taken both before and after incineration to reduce these emissions. Neglecting the limits of the incineration plant will result in operational problems (e.g., the necessity of repeated shutdowns due to cleaning of the grate or heat exchangers) or in a bad environmental performance (e.g., high emissions into water, high leachability of fly ash). Figure 7 shows the typical layout of a large municipal solid waste incinerator.

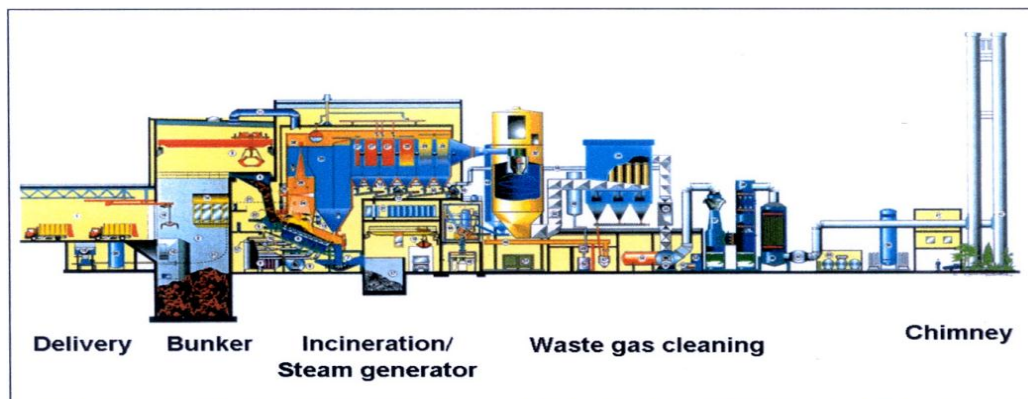

**Figure 4 Typical municipal solid waste incinerator (Source: European Commission 2006)****2.2.4.1.2 Municipal solid waste incinerator designs**

Municipal solid waste can be incinerated in several combustion systems, including travelling grate, rotary kilns, and fluidized beds. Fluidized bed (see subsection 2.2.3.4) technology requires municipal solid waste to be of a certain particle size range – this usually requires some degree of pretreatment and the selective collection of the waste. Combustion capacities of municipal solid waste incinerators typically range from 90 to 2,700 tons of municipal solid waste per day (modular configurations: 4 to 270 tons per day).

Other processes have been developed that are based on the decoupling of the phases that also take place in an incinerator: drying, volatilization, pyrolysis, carbonization and oxidation of the waste. Gasification using gasifying agents such as steam, air, oxides of carbon or oxygen is also applied. These processes aim to reduce flue gas volumes and associated flue gas treatment costs. Many of these developments have come up against technical and economic problems when scaled up to commercial and industrial dimensions, and are therefore no longer pursued. Some are used on a commercial basis (e.g., in Japan) and others are being tested in demonstration plants throughout Europe, but still have only a small share of the overall treatment capacity when compared to incineration.

**2.2.4.2 Hazardous waste incineration**

Hazardous waste is commonly burned in rotary kilns or in grate incinerators. Other types of incinerators used for hazardous waste include fluidized beds, liquid injection units, and fixed hearth units. Before accepting a hazardous waste for treatment, merchant incinerators must assess and characterize the material. Documentation by the producer is routinely required, including the origin of the waste, its code or other designation, the identification of responsible persons and the presence of particular hazardous materials. The waste must also be properly packaged to avoid the possibility of reaction and emissions during transport.

Storage at the incinerator site will depend on the nature and physical properties of the waste. Solid hazardous waste is typically stored in bunkers constructed to prevent leakage into any environmental media and enclosed to allow the removal of bunker air to the combustion process. Liquid wastes are stored in tank farms, often under inert gas atmosphere (for example N<sub>2</sub>), and transported to the incinerator by pipeline. Some wastes may be fed directly to the incinerator in their transport containers. Pumps, pipelines and other equipment that may come into contact with the wastes must be corrosion-proof and accessible for cleaning and sampling. Pretreatment operations may include neutralization, drainage or solidification of the waste. Shredders and mechanical mixers may also be used to process containers or to blend wastes for more efficient combustion.

Hazardous waste is also incinerated in cement kilns. This application is addressed in the cement chapter of the guidance document.

**2.2.4.3 Sewage sludge incineration**

Domestic sewage sludge is disposed of in a number of ways, including application on agricultural land after pretreatment, surface disposal (e.g., landscaping, landfilling), incineration, co-disposal with municipal solid waste and co-incineration. The incineration of sewage sludge is practiced in several countries, either alone or through co-incineration in municipal solid waste incinerators or in other combustion plants (e.g., coal-fired power plants, cement kilns). The effective disposal of sewage sludge by this process depends on a number of factors. These include whether the sewage is mixed with industrial waste streams (which can increase heavy metal loadings), location (coastal locations can result in salt water intrusion), pretreatment (or the lack thereof), and weather (rainfall dilution) (EU IED, 2010).

The incineration of sewage sludge presents some differences from the incineration of municipal solid waste and hazardous waste. The variability of moisture content, energy value, and possible mixture with other wastes (e.g., industrial waste if sewage systems are interconnected) require special considerations in handling and pretreatment.

Solid residues from sewage sludge incineration mainly consist of fly ash and bed ash (from fluidized bed incineration) and residues from flue gas treatment (see the description of municipal solid waste incineration in 2.2.4.1 above). Appropriate flue gas cleaning measures have to be combined in a suitable manner to ensure the application of best available techniques (see section 5.5 below).

**2.2.4.4 Design and operation of sewage sludge incinerators**

A typical sewage sludge incinerator may process as much as 80,000 tons of sewage sludge (35 per cent dry solids) per year. The incineration technologies of choice for sewage sludge are the multiple hearth (figure 5) and fluidized bed furnace systems, although rotary kilns are also used in smaller applications.



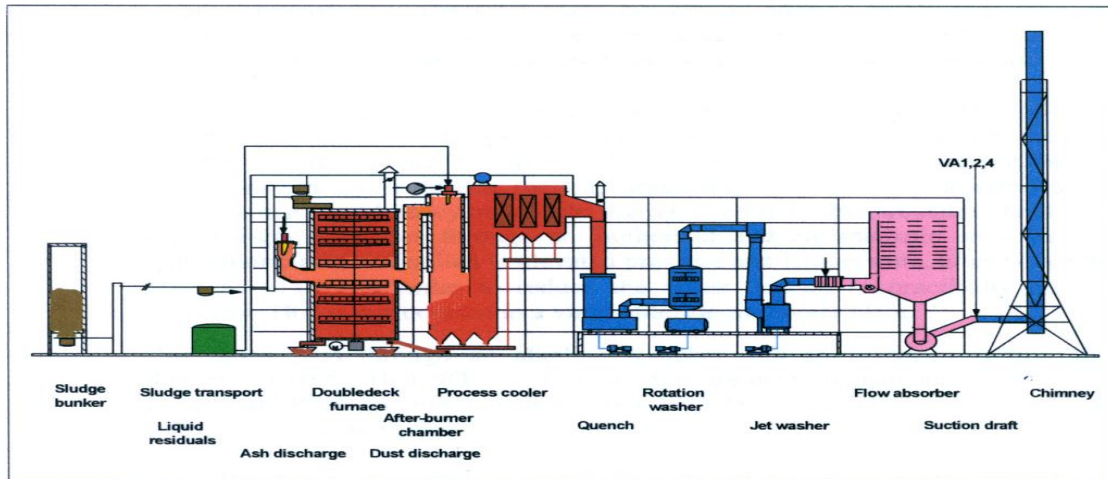

**Figure 5 Example of a multiple hearth sewage sludge incinerator (European Commission, 2006)**

Depending on the percentage of dry solids (dryness), an auxiliary fuel, usually heating oil or natural gas, is provided. The preferred operating temperatures are in the range of 850 °C–950 °C with a two-second residence time, although some fluidized bed facilities are able to operate at a temperature as low as 820 °C without deterioration in performance. Operation at or above 980 °C can cause ash to fuse (European Commission 2006).

Sewage sludge is co-incinerated with municipal solid waste in both fluidized bed and mass burn (grated) incinerators. In the latter case, a ratio of 1:3 (sludge to waste) is typical, with dried sludge introduced into the incineration chamber as a dust or drained sludge applied to the grate through sprinklers. In some cases, drained or dried sludge may be mixed with municipal solid waste in the bunker or hopper before being charged to the incinerator. The feeding methods represent a significant proportion of the additional capital investment required for co-incineration.

#### 2.2.4.4.1 Pretreatment of sewage sludge

Pretreatment, especially dewatering and drying, is of particular importance in preparing sludge for incineration. Drying reduces the volume of the sludge and increases the heat energy of the product. Moisture removal to at least 35 per cent dry solids is normally required to provide the necessary heat energy for autothermal incineration. Further drying may be necessary if co-incineration with municipal solid waste is envisaged.

Some pretreatment of sludge may occur before delivery to an incineration facility. This may include screening, anaerobic and aerobic digestion, and the addition of treatment chemicals.

Physical dewatering reduces sludge volume and increases heating value. Mechanical dewatering processes include decanters, centrifuges, belt filter and chamber filter presses. Conditioners (for example, floccing agents) are often added before dewatering to facilitate drainage. Mechanical dewatering can routinely achieve 20–35 per cent dry solids (European Commission, 2006).

Drying introduces heat to further dewater and condition the sludge. Heat for drying at the incineration facility is often provided by the incineration process itself. Drying processes can be direct (sludge contacts thermal carrier) or indirect (for example, heat supplied by steam plant). In direct drying, the vapour and gas mixture must be subsequently cleaned.

Autothermal (self-sustaining) incineration of sludge requires 35 per cent dry solids. Although mechanical dewatering can reach this threshold, additional drying of sludge to as much as 80–95 per cent dry solids may be employed to increase the heat value. Co-incineration with municipal solid waste generally requires additional sludge drying.

#### 2.2.4.5 Waste wood incineration

Wood waste containing or contaminated with mercury can be burned in grate incinerators or in fluidized bed incinerators at the same temperatures as that applied to municipal waste incineration.

Another technique used is pyrolysis. Three products are usually produced: gas, pyrolysis oil and charcoal, the relative proportions of which depend very much on the pyrolysis method, the characteristics of the biomass and the reaction parameters. Fast or flash pyrolysis is used to maximize either gas or liquid products according to the temperature employed.

#### 2.2.4.6 Behaviour of mercury during the incineration process

This section discusses the behaviour of mercury during the incineration process. As described in section 3, the ability of various controls to capture emissions is related to the speciation of mercury in the flue gas.

Owing to the thermo-chemical instability of mercury compounds, at temperatures above 700 °C–800 °C only elemental mercury exists. This means that inside the combustion chamber of a waste incinerator, mercury is present only in its elemental form. Mercury is highly volatile and, therefore, almost exclusively present in the vapour phase in the flue gas. On its way through the heat recovery section the flue gas cools down and the elemental mercury reacts depending on the presence of other flue gas components, temperature, and ash composition to oxidized mercury. The oxidized mercury compounds are generally unstable in the flue gas and under atmospheric conditions (Galbareth, Zygarlicke 1996).

Under certain conditions, elemental mercury can be oxidized. The extent of the conversion depends on the temperature, residence time, ash, unburnt carbon and the presence of gas-phase species including chlorine or SO<sub>2</sub>. The distribution of elemental mercury and oxidized mercury in the form of mercury (II) chloride depends strongly on the amount of HCl in the flue gas. The proportion of oxidized mercury and total mercury tend to increase with increasing hydrogen chloride concentration (Nishitani et al., 1999). Owing to the lower content of HCl in sewage sludge incineration plants, the share of elemental mercury is significantly higher.

### 3 Emission control techniques

The type and order of treatment processes applied to the flue gases once they leave the incineration chamber is important, both for optimal operation of the devices and for the overall cost-effectiveness of the installation. Waste incineration parameters that affect the selection of techniques include: waste type, composition, and variability; type of combustion process; flue gas flow and temperature; and the need for, and availability of, wastewater treatment. The following treatment techniques have direct or indirect impacts on preventing or reducing the emissions of mercury. BAT involves applying the most suitable combination of flue gas cleaning systems. General descriptions of a number of the techniques are provided in the introduction to this guidance (section 1). Information considered specific to waste incineration is presented in the following sections.

#### 3.1 Dust (particulate matter) removal techniques

Dust removal from the flue gases is essential for all incinerator operations. Electrostatic precipitators (ESPs) and fabric filters (FFs) have demonstrated effectiveness as capture techniques for particulate matter in incinerator flue gases. For a description of the general principles of these techniques, see the introductory , of this document.

To more efficiently remove mercury from flue gas, both FFs and ESPs are used in combination with other techniques (see sections 3.4–3.5 below).

Pressure drop across fabric filters and flue gas temperature (if a scrubbing system is used upstream) should be monitored to ensure that the filter cake is in place and that bags are not leaking or getting wet.

Fabric filters are subject to water damage and corrosion and gas streams must be maintained above the dew point (130 °C–140 °C) to prevent these effects. Some filter materials are more resistant to damage.

*Cross-media effects on the leaching of mercury from fly ash* (EC, 2006, Waste Incineration)

The fly ash generated from flue gas cleaning systems should be handled with care since it has the potential to leach mercury into land and ground water.

*Cross-media effects (non-mercury-related)*

ESPs and FFs used in dust removal have high energy consumption due to electrostatic loading, high pressure drop and pulsing high pressure air cleaning. The residue amount is 12–20 kg/t waste input.

*Costs of installation and operation* (EC, 2006, Waste Incineration)

Investment costs for a two-line municipal solid waste incinerator of total capacity 200 000 t/yr are estimated as:

ESP (three field): €2.2 million

ESP (two field): €1.6 million

FF: €2.2 million (not clear if this includes an upstream flue gas cooler)

*Co-benefits on the use of FFs coupled with spray drying or semi-dry sorbent injection*

For separation of other pollutants such as dust, other heavy metals and dust-bonded organic compounds, fabric filters have the added advantage when coupled with dry or semi-dry sorbent injection (spray drying) of providing additional filtration and reactive surface on the filter cake.

#### 3.2 Wet scrubbing techniques

Gaseous mercury can be captured by adsorption in a wet scrubber. In the first stage the removal efficiency of oxidized mercury as  $\text{HgCl}_2$  (which is generally the main compound of mercury after waste combustion) is over 95 per cent. (EC, 2006, Waste Incineration). The removal rates of elemental mercury, however, are only in the order of 0–10 per cent, mainly as a result of condensation at the scrubber operational temperature of around 60 °C–70 °C.

Precipitation is another measure often used to minimize the concentration of oxidized mercury in the scrubbing water. A flocculation agent (often a sulfur compound) is added to the scrubbing water and converts the soluble mercury into an insoluble compound with reasonable efficiency, particularly in the second stage. To bind the mercury directly after the conversion into the liquid phase, another possibility is to add activated carbon to the scrubbing water (Bittig 2014). Re-emission of dissolved mercury to the flue gas can be avoided by complexing the dissolved mercury with sequestering agents e.g., organic sulfides (Keiser et al., 2014).

With the measures mentioned above, elemental mercury adsorption can be improved from 20 per cent up to a maximum of 30 per cent. The overall mercury removal (both metallic and oxidized) efficiency is around 85 per cent (EC, 2006, Waste Incineration).

*Cross media effects*

Non mercury-related cross media effects are shown in table 1

**Table 1**

Cross-media effects – non-mercury-related

Reagent consumption	2–3 kg (NaOH) or 10 kg CaO or 5–10 kg lime stone per ton waste input
Residue amount:	10–15 l/t waste input
Water consumption:	100–500 l/t waste input
Emissions to water:	250–500 l/t waste input

Source: WT BREF 2005

Process wastewater in incineration arises mainly from the use of wet scrubbing techniques. Releases of wastewater can be avoided by injecting them into the flue gas with a spray absorber or a comparable system. For example, in Germany, there are only very few incineration plants which have water releases from flue gas treatment.

If there is no injection of wastewater into the flue gas, the scrubber effluents should be treated in a physico-chemical treatment installation. For the removal of mercury, a two-stage precipitation should be applied. With a combination of a two-stage precipitation with ultra filtration or a mercury specific ion exchanger, concentrations below 1 µg/l can be achieved (Marson et al, 2013, Riethman, 2013, Owens et al, 2013, Scheidereit 2014).

#### Costs

Costs of installation and operation are shown in table 2.

**Table 2**

Costs of installation and operation

FGT component	Estimated investment costs	Comments
Two-stage wet scrubber	€5 million	Including waste water treatment
Three-stage wet scrubber	€7 million	Including waste water treatment
External scrubber effluent evaporation plant	€1.5 million–€2 million	
Spray absorber for internal effluent evaporation	€ 1.5 million	Cost estimate believed to be on the low side

Source: EC, 2006, Waste Incineration

Information from a plant manufacturer from 2014

For a 200,000 ton plant with two incineration and flue gas treatment lines: FF + 2 stage scrubber: €16 million–€18 million.

#### Co-benefits of the use of carbon-impregnated materials

For the separation of acid gases, dust and dust-bonded ingredients, the use of carbon-impregnated materials, activated carbon, or coke in scrubber packing materials can achieve 70 per cent reduction in polychlorinated dibenzodioxins (PCDDs) and polychlorinated dibenzofurans (PCDFs) across the scrubber but this may not be reflected in overall releases (European Commission, 2006).

### 3.3 Activated carbon injection

The use of activated carbon to enhance the removal of mercury is described in a general way in the introductory chapter of this document. The activated carbon technique involves the injection of activated carbon or hearth furnace coke (HOK) upstream of a bag filter (see section 3.1 above) or other dedusting device. As a result, most of the mercury is then adsorbed at the filter layer. Accordingly, FFs are usually pre-coated with reagents before start-ups to ensure that a good abatement performance is already achieved when waste feeding starts.

A good mixture of the adsorbent materials with the flue gas and a sufficient contact time are important for a successful precipitation. Dosing of carbon-based adsorbents in the flue gas before a downstream fabric filter, e.g., after a scrubber is a well established last step of the gas cleaning.

Consideration of the speciation mix of the flue gas is key to estimating the mercury emission control efficiency of the activated carbon. In general, the oxidized species of mercury are considered more easily controlled than the elemental form. The halogen content of the waste is important in determining the amount of oxidation taking place. High halogen content in the flue gases, and thus high percentages of oxidized mercury, may often exist in municipal waste incinerators. The removal efficiency of the injection of activated carbon in combination with a FF can be as high as 95 per cent.

The separate injection of activated carbon, controlled by continuous mercury monitoring in the raw gas, has proved to be very effective in waste incineration. In this way the added amount of activated carbon can be adapted to the raw gas concentrations of mercury. In addition, in the event of mercury peaks in the raw gas, highly effective activated carbon impregnated with about 25 per cent sulfur can be injected. This approach combines an effective mercury abatement with the decreased operation costs resulting from a reduced use of sorbents. It should be noted that the investment costs of a mercury gas measuring device could be significantly lower than those for a clean gas device because measurement devices tested for suitability are not necessary (Esser-Schmittmann 2012).

In particular, in cases where there are relatively high concentrations of elemental mercury in the flue gas, e.g., at sewage sludge incineration plants, satisfactory reduction efficiencies can only be achieved when activated carbon impregnated with sulfuric acid or halogen (e.g., bromine) is used.

Tests have shown that the Hg reduction ratio increases as the flue gas temperature decreases and that the reduction efficiency is significantly higher when there are high concentrations of mercury in the raw gas (Takaoka et al. 2002).

The removal efficiency of the carbon sorbents increases if a fabric filter is used instead of an ESP, owing to the longer residence time allowing more contact between the sorbent and the mercury-laden flue gas. As a result, only a third of the sorbent is needed to capture the same amount of mercury compared to an ESP (LCP BREF Draft 2013).

For a more effective removal of mercury from flue gases, use is made of specially developed activated carbon impregnated with sulfuric acid, elemental sulfur or bromine. In this case, the removal of mercury is driven by chemisorption, and also by physisorption. Tests have shown that the mercury reduction efficiency can be increased to 99 per cent.

#### *Cross-media effects (non-mercury-related)*

Carbon consumption rates of 3 kg/ton of waste are typical for municipal solid waste incineration. Levels ranging from 0.3 to 20 kg/ton of hazardous waste have been reported (EC, 2006, Waste Incineration).

#### *Costs of installation and operation*

For a 200,000 ton plant with two incineration and flue gas treatment lines: the costs of dry flue gas treatment, including storage of sorbents, dosing systems, control of sorbent injection, FF and ash discharge, range between €5.5 million and €6 million installation cost.

The installation costs for storage of the activated carbon are approximately €50,000 for smaller plants (container storage) and approximately €100,000 for bigger plants (silo storage) (data from Germany, 2014).

The operation costs depend on the kind of carbon which is used. For HOK the cost is approximately €300 per ton; for weak sulfuric acid-impregnated carbon (5 per cent) approximately €400 per ton; for high sulfur-impregnated carbon approximately €2,000 per ton; and for bromated activated carbon approximately €1,500 per ton.

The usage of low sulfuric acid-impregnated carbon for a 300,000 ton municipal waste incineration plant is estimated at 30 t/y for a plant using a police filter and 200 t/y for a plant equipped with a dry flue gas treatment system (data from Germany, 2014).

#### *Co-benefits*

Separation of volatile organic compounds such as dioxins can also be achieved in the flue gas. It is normal for alkaline reagents to be added together with the carbon; this then also allows the reduction of acid gases in the same process step as a multifunctional device.

### 3.4 Boiler bromide addition

Addition of bromide into the furnace can enhance the oxidation of mercury during the passage through the boiler of the flue-gas, thereby promoting the transformation of insoluble elemental gaseous mercury into its water-soluble mercury (II) bromide ( $\text{HgBr}_2$ ), and also into adsorbable mercury species. Mercury removal can thereby be enhanced in existing downstream control devices, such as wet scrubbers. Another option for the addition of halogens is to add bromide or other halogen compounds to the waste (Vosteen 2006).

It should be noted that boiler bromide addition (BBA) alone does not reduce mercury emissions as such, in the sense of capturing elemental mercury as  $\text{HgBr}_2$ . BBA promotes mercury oxidation and thereby indirectly reduces mercury emissions at existing wet air pollution control (APC) systems as wet desulfurization scrubbers or dry desulfurization scrubbers; thus, BBA improves the efficiency of activated carbon injected at units with particulate scrubbers (ESP, FF) (LCP BREF Draft Version 2013).

In waste incineration plants, this technique is beneficial in cases where the waste contains low levels of halogens. It is therefore applied mainly in sewage sludge incineration plants and hazardous waste incineration plants burning waste with low halogen levels. For example, in a German waste incineration plant for hazardous waste, flue gas is monitored continuously. The monitoring takes place after the wet scrubber, but before the tail-end selective catalytic reduction (SCR), because SCR devices retain mercury and this is then slowly released again. If a significant increase of mercury is detected after the wet scrubber, bromine compounds are injected into the boiler. This results in considerably lower mercury emissions in the clean flue gas (Vosteen, 2006). This technique is not effective in the case of very short mercury peaks in the flue gas, because the peak has passed the flue gas treatment system before there is a possibility to react.

In general, it was reported that, by applying Br/Hg mass ratios of more than 300, complete mercury oxidation can be achieved. It has recently been demonstrated at two French hazardous waste incineration plants using mainly dry flue gas cleaning that the mercury removal efficiency associated with the use of activated carbon was almost 100 per cent. This efficiency was seen in the presence of almost only oxidized mercury (Chaucherie et al., 2015). A similar removal efficiency of 99.8 per cent was achieved with a multistage scrubbing system.

The use of bromine in the process may lead to the formation of polybrominated dioxins and polyhalogenated dioxins and furans which are undesirable. It should be noted that emissions of these substances, if occurring, need to be controlled.

#### *Cross-media effects*

Mercury measurements can be very difficult if bromine is present in the flue gas. There is a potential for bromine-induced corrosion in the ductwork, air heater and in flue gas desulfurization (FGD) systems. Bromine-induced corrosion commonly goes together with an increased bromine and mercury content in the fly ash (LCP BREF Draft Version, 2013).

#### *Costs of installation and operation*

The use of activated carbon injection in conjunction with BBA may be more cost-effective than the use of either method alone in order to achieve the same level of performance.

### 3.5 Static bed filters

Activated coke moving bed filters are used as a secondary cleaning process in the flue gas of municipal and hazardous waste incineration plants. Using this adsorption system, it is possible to deposit substances contained in the flue gas at low concentrations with efficiencies as high as 99 per cent. Lignite coke produced in hearth furnace coke process is used in moving bed absorbers.

The flue gases pass through a filling of grained hearth furnace coke (HFC) – a fine coke of 1.25 mm–5 mm). The depositing effect of HFC is essentially based on adsorption and filtration mechanisms. It is thus possible to deposit almost all emission-relevant flue-gas components, in particular, residual contents of hydrochloric acid, hydrofluoric acid, sulfur oxides, and heavy metals (including mercury), to levels sometimes below the detection limit.

The flue gas is guided to the activated coke filling over a distributor bed equipped with a multitude of double funnels. The gas flows through them from the bottom to the top, while the HFC passes through the absorber from the top to the bottom. This makes possible an ideal distribution of the flue gas over the entire cross-section of the absorber, with optimal use of the capacity of the absorber and minimum consumption of the activated coke.

An essential feature of the moving bed system is its high efficiency with all emissions, due to the large bulk of activated coke, so that variations from incineration and upstream flue-gas cleaning caused by operation will not have disadvantageous effects.

Because of the carbon contained in the static bed filters, there is a possibility of fire outbreak. As a result of fire risk and high costs, the systems are installed only in few plants. Care should be taken to avoid any fire outbreak, including through the installation of a dampening system.

*Cross-media effects that are non-mercury-related (WT BREF 2005)*

The non-mercury-related cross-media effects include the following:

- Energy consumption: 30–35 kWh/ton waste input
- Reagent consumption: 1 kg/ton waste input
- Residue amount: 0–1 kg/ton waste input

*Costs of installation and operation of coke filter*

The investment cost of a coke filter for a 100,000 ton/y municipal solid waste incinerator was estimated at €1.2 million. The investment costs for one static bed wet filter (empty) (incineration line of 50,000 t/y) is approximately €1 million (EC, 2006, Waste Incineration)

*Co-benefits*

The co-benefits of using activated coke bed-moving filter include the separation of volatile organic compounds, such as dioxins, in the flue gas.

### 3.6 Illustrative examples for emission values achieved with the techniques described above.

The following tables and figures illustrate performance achieved with the application of the above techniques. Figure 6 shows annual mean values of mercury emissions for different combined or one-step waste gas control techniques of 51 plants used for incineration of municipal, medical and hazardous waste from plants in Germany. All plants are equipped with continuous mercury measurement. For each technique combination, the mean of all reported values is indicated (centre line) together with the standard variation (orange) and the minimum and maximum values (grey).

The mean annual emission value is about  $2.5 \mu\text{g}/\text{Nm}^3$  (yearly average based on daily averages), similar for all combinations of control techniques installed. More than 90 per cent of the installations emit less than  $10 \mu\text{g}/\text{m}^3$ . All applied combinations of techniques are appropriate for mercury reduction, as demonstrated by the small ranges of the annual emission values reported for each combination.

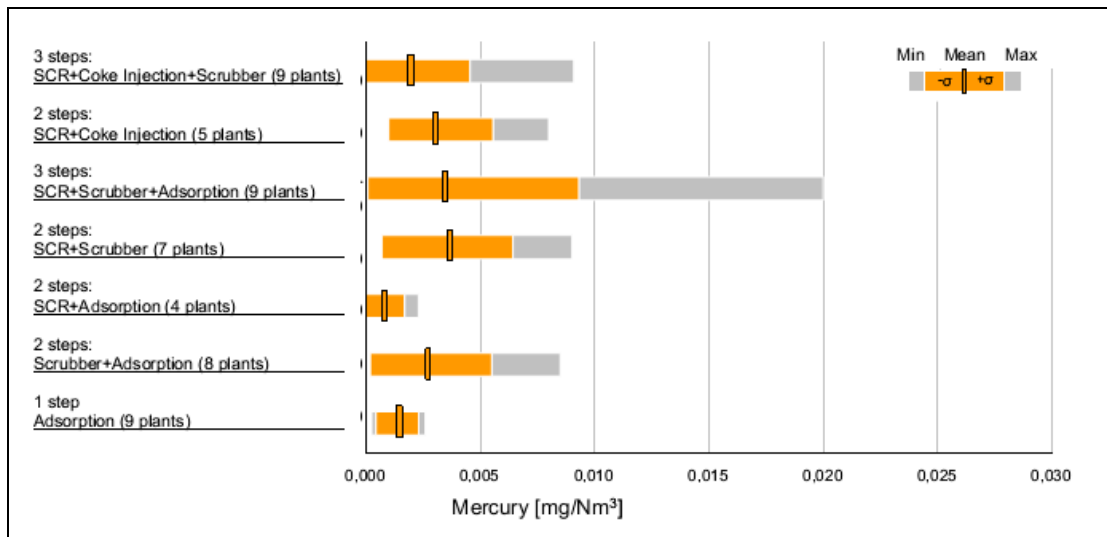

**Figure 6 Comparison of waste gas control techniques for mercury reduction (number of plants in brackets) (Daschner et al., 2011)**

Actual measurement data from industrial waste and municipal waste incinerators in Japan is shown in Table 3 and 4. In the case of industrial waste incinerators, however, there is a large deviation in mercury concentrations of flue gas. It should be noted that not all of these plants, municipal waste incineration as well as hazardous waste incineration, use activated carbon. Better performance is generally achieved at installations with injection of activated carbon.

**Table 3**

Distribution of mercury concentration (mg/Nm<sup>3</sup>) of flue gas by flue gas treatment technology (municipal waste incinerator)

Flue gas treatment type	Min.	Arithmetic mean	Max.	Standard deviation $\sigma$
FF + Slaked lime injection (dry) (86 incinerators)	0.0005	0.0176	0.165	0.022
FF + Scrubber (32 incinerators)	0.0002	0.0114	0.074	0.015
FF + (Slaked lime or scrubber) + Activated carbon treatment (229 incinerators)	0.0002	0.0081	0.249	0.020
ESP + Scrubber (9 incinerators)	0.004	0.0154	0.047	0.014
ESP + Scrubber + Activated carbon treatment (11 incinerators)	0.0005	0.0043	0.014	0.004

Activated carbon treatment: Activated carbon injection, activated carbon adsorption tower or activated coke adsorption

**Table 4**

Distribution of mercury concentration (mg/Nm<sup>3</sup>) of flue gas by flue gas treatment technology (industrial waste incinerator)

Type of flue gas treatment, business permit		Min.	Arithmetic mean	Max.	Standard deviation $\sigma$
<b>FF (with dry or wet system)</b> Industrial waste <sup>a</sup> (18 incinerators)	*1	0.0001	0.0057	0.046	0.010
<b>FF (with dry or wet system)</b> Infectious waste or industrial hazardous waste (15 incinerators)	*1	0.0002	0.0062	0.039	0.0084
<b>FF + Scrubber (liquid chelating agent added)</b> Industrial waste, infectious waste or industrial hazardous waste (5 incinerators)	*2	0.0004	0.0064	0.035	0.0077
<b>ESP + Scrubber</b> Industrial waste, infectious waste or industrial hazardous waste (7 incinerators)	*3	0.0001	0.035	0.210	0.051

<sup>a</sup>The term "industrial waste" here does not include industrial hazardous waste.

\*1 : Incinerators with flue gas treatment by fabric filters (FF) and one or more of the following: scrubbers (water or alkali washing), activated carbon injection, activated carbon adsorption tower or catalytic reactor

\*2 : Incinerators with flue gas treatment by a combination of FF and scrubbing solution added with liquid chelating agent for mercury removal.

\*3 : Incinerators with flue gas treatment by a combination of electrostatic precipitator (dry or wet) and scrubbers. Some of the incinerators also have activated carbon injection (continuous) or activated carbon adsorption towers.



Trials at a Japanese stoker-fired waste incineration plant for municipal waste equipped with a spray tower and following  $\text{Ca}(\text{OH})_2$  and ACI injection before a FF showed emission levels in a range between 0.4 and 11.3  $\mu\text{g}/\text{m}^3$  (Takaoka 2002).

The figure and the tables in section 3.6 show that at almost all installations concentrations below 10  $\mu\text{g}/\text{m}^3$  can be achieved, especially when activated carbon is used in combination with other techniques. Some plants in Europe and Japan show mercury emission concentrations below 1  $\mu\text{g}/\text{m}^3$ .

### 3.7 Use and disposal of solid residues from incineration

Although this guidance is primarily concerned with air emissions, account should also be taken of cross-media effects. Accordingly, the following section provides information on managing residual waste from the incineration process, including preventing or minimizing risks of leaching or distribution through the environment through a number of pathways.

Wastes and residues from incineration include various types of ash (e.g., bottom ash, boiler ash, fly ash) and residues from other flue gas treatment processes (such as gypsum from wet scrubbers), including liquid effluents in the case of wet scrubbing systems.

Because constituents of concern may vary considerably, maintaining the separation of residues for treatment, management and disposal is generally advisable. The presence and concentration of mercury and its compounds in these residues (if separately treated) is a function of their presence in the incoming waste and capture during flue gas treatment. Air pollution control residues in particular should be treated in such a manner as to avoid additional evaporation or the leaking of mercury and its compounds.

The release of contaminants from these dry materials into the environment may occur via a number of routes, including: wind-blown dust, leaching to groundwater, plant uptake or direct ingestion by humans, domesticated animals and wildlife. Management of these materials must be carried out with due consideration of these potential releases.

#### 3.7.1 Treatment of solid flue gas residues

One major flue gas treatment residue (or air pollution control residue) is fly ash. Fly ash removal from flue gas by use of dry scrubbers, cyclones or fabric filters in waste incinerators will result in dry and fine solid particulate material acquiring a range of properties and contaminants depending on the combustion source that produced it. Unlike bottom ash, air pollution control device residuals, including fly ash and scrubber sludges, contain relatively high concentrations of heavy metals, persistent organic pollutants, chlorides and sulfides. The separate removal of fly ash and residues from flue gas cleaning stages (e.g., those for acid gas and dioxin removal) prevents the mixing of low contaminated waste fractions with those that are highly contaminated. Most mercury in waste streams ends up in the residues when pollution abatement measures are installed (European Commission 2006, Song, Kim et al. 2004).

In Switzerland the treatment of fly ash with acid wastewater from the scrubber is widespread. To avoid mercury contamination of the treated ash, the acid wastewater is first cleaned with a candle filter, followed by a mercury-specific ion-exchange unit. This water, from which mercury has been removed, can be used to wash heavy metals from the fly ashes. The wash water is subsequently treated in a classic flocculation and precipitation unit. For the final cleaning of the wastewater a second ion exchanger is used.

The cleaned fly ash can be added to waste in the waste incineration plant to destroy the organic components in the fly ash (Bühler et al. 2015, Adam et al. 2010, BSH 2015).

Fly ash is disposed of in dedicated landfills in many countries. To meet BAT standards, however, pretreatment is likely to be required for this (see, for example, Song, Kim et al. 2004), depending on national landfill acceptance criteria. More detailed information on waste incinerator residues containing mercury management can be found in the Basel Convention ESM technical guidance for mercury wastes (Basel Convention Secretariat 2015).

#### 3.7.2 Stabilization and solidification

Treatment and disposal options for solid residues from flue gas control systems include solidification or stabilization with Portland cement (or other pozzolanic materials), alone or with additives or a number of thermally based treatments, followed by appropriate disposal in conformity with national landfill acceptance criteria (based on anticipated releases from the treated residuals). The need for such treatment can be determined based on an evaluation of the release potential of these residues. More detailed information on treatment methods can be found in the Basel Convention ESM technical guidance for mercury wastes (Basel Convention Secretariat 2015)

### 3.7.3 Bottom and fly ash use

Because of the differences in pollutant concentration, the mixing of bottom ash with fly ash will contaminate the former and is forbidden in many countries. The separate collection and storage of these residues may provide operators with more options for disposal. Whenever bottom ash is to be further used (e.g., as construction material), mixing with other flue gas treatment residues is generally not a BAT. Bottom ash (or slag from fluidized bed incinerators) is disposed of in landfills in many countries but may be reused in construction and road-building material following pretreatment. Prior to such use, however, an assessment of content and leachability should be conducted and upper levels of heavy metals and persistent organic pollutants should be determined. Pretreatment techniques include dry, wet and thermal treatment, and also the screening, crushing and separation of metals.

The use of fly ash and mixed waste incineration residues for construction purposes has potential environmental risks due to contamination by heavy metals. There are examples which demonstrate that such practice can lead to serious environmental contamination (Pless-Mulloli, Edwards et al. 2001; Watson 2001; Petrlik and Ryder 2005; Shaheen et al. 2014).

Bottom and fly ashes from waste incinerators should never be used as soil amendment in agricultural or similar applications if their mercury concentration exceed levels of concern. Addition to soil may result in subsequent dispersion of the ash and any contaminants. In agricultural uses, plants may take up contaminants, resulting in exposure to human or animals that consume such plants (Skinner et al, 2007). Pecking or grazing animals may directly ingest contaminants with subsequent exposure to humans when they consume the animals or animal products (e.g., milk and eggs) (de Vries et al., 2007).

### 3.7.4 Final disposal of residues

If there is recycling of materials other than mercury in the waste, adequate precautions should be taken to prevent emissions of mercury from that process. When disposed of in a landfill, evaluation of the release potential and the appropriateness of the landfill for this type of material should be considered. More detailed information can be found in the technical guidelines for the environmentally sound management of wastes consisting of elemental mercury and waste containing or contaminated with mercury or mercury compounds (Basel Convention, 2015).

## 3.8 Alternative treatment techniques for waste streams that can generate emission of mercury and mercury compounds when incinerated

This section describes some alternative treatment technologies that are currently commercially available. The goal of an alternative treatment technology would be to achieve the same degree of destruction of the organic compounds, while controlling potential releases of residual mercury.

For municipal waste, possible alternatives to incineration are:

- Zero waste management strategies which aim to eliminate the generation of waste through the application of a variety of measures, including legislative and economic instruments (circular economic policy and recycling insurance) (Greyson, 2007; Matete and Trois, 2008; Allen, Gokaldas et al., 2012);
- Waste minimization, source separation and recycling to reduce the waste volume requiring final disposal;
- Mechanical biological treatment, which reduces waste volume by mechanical and biological means and generates residues requiring further management (Bilitewski, Oros et al. 2010); (Velis, Longhurst et al. 2009).

For medical waste, possible alternatives to incineration use are:

- Exposure of waste to saturated steam under pressure in a pressure vessel or autoclave;
- Advanced steam sterilization systems. Advanced autoclaves or advanced steam sterilization systems combine steam treatment with pre-vacuuming and various kinds of mechanical processing before, during and after steam treatment;
- Microwave treatment;
- Dry heat sterilization.

These alternatives are well described in the Stockholm Convention BAT/BEP Guidelines (Stockholm Convention, 2008) and in the UNEP Compendium of Technologies for Treatment/Destruction of Healthcare Waste (Emmanuel, 2012). UNEP has also developed an interactive Excel-based software that facilitates use of the sustainable assessment of technologies methodology for selecting health-care waste treatment technologies (Emmanuel, 2012).

For hazardous wastes, some possible alternatives are listed in chapter III of the Basel Convention Technical Guidelines on Mercury Waste (Basel Convention, 2015) and, in particular for soil contaminated with mercury, also in Bell's study of contaminated sites in Kazakhstan (Bell, 2015)

## 4 Emerging techniques

### 4.1 High efficiency activated carbon adsorber

A high efficiency activated carbon adsorber, trade-named “JFE-Gas-Clean-DX,” has been developed, in which activated carbon is packed in an activated carbon cartridge with a fixed bed and lateral flow-type structure, thereby realizing efficient contact between the flue gas and the activated carbon.

**Error! Reference source not found.**7 provides a schematic illustration of the appearance of the device and figure 8 the activated carbon cartridge. The device consists of an activated carbon cartridge, of a compact size, which can be easily detached and installed in the device housing. High efficiency contact between the flue gas and activated carbon is realized by adopting a fixed bed and lateral flow type structure.

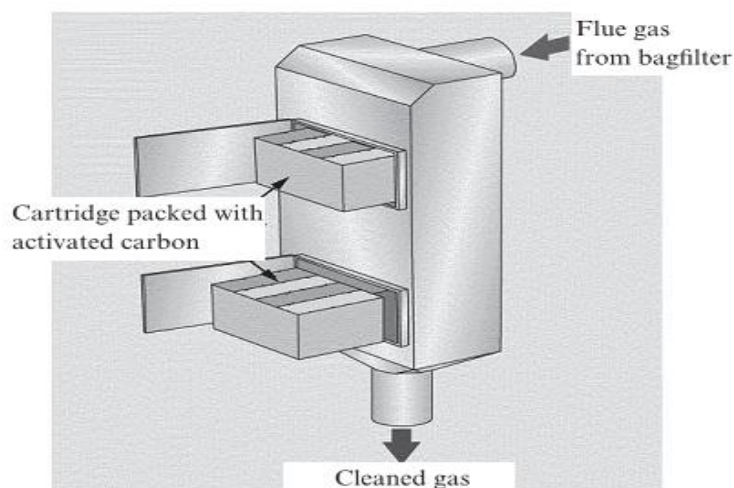

**Figure 7** Activated carbon adsorber

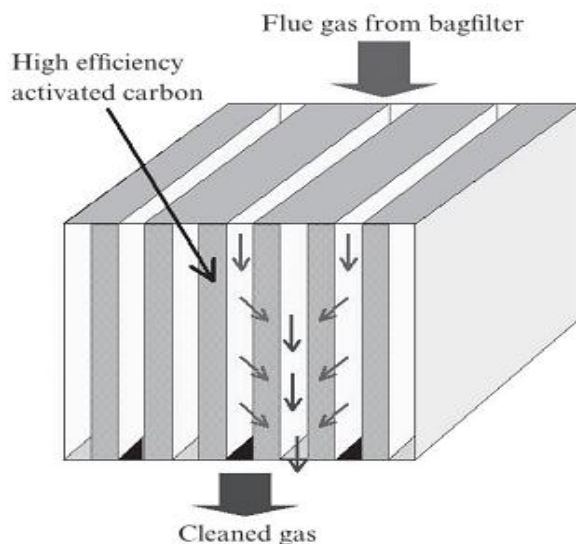

**Figure 8** Cartridge packed with activated carbon

As shown in Figure 8, flue gas is uniformly dispersed as it passes through the multiple thin packed layers of activated carbon installed in the activated carbon cartridge. As a result, contact efficiency between the activated carbon and trace harmful substances in the flue gas is high and a large decrease in activated carbon use is necessary. As an additional advantage, because thin layers of activated carbon are used, pressure loss is low in comparison with the conventional moving bed-type activated carbon adsorber, which has pressure loss of approximately 2–3 kPa. Because the pressure loss is no more than 0.5 kPa per activated carbon cartridge stage, electric power consumption can be kept to a low level. To prevent dust from clogging the packed bed of activated carbon, the basic method when applying this device is installation after the bag filter. For this reason, activated carbon with high ignition prevention performance

should be used, enabling treatment up to a maximum service temperature of 200 °C, which is the temperature of general bag filters.

Trials at a waste incineration plant have shown mercury concentrations below the detection limit of 5 µg/m<sup>3</sup> in the clean gas during an inlet concentration of 65 µg/m<sup>3</sup>. The Hg concentrations under the minimum determination limit were being maintained after six months at the waste incineration plant.

#### *Co-benefits*

Co-benefits include the reduction of other harmful substances such as dioxins and other heavy metals.

## **4.2 Coconut char as an alternative to coal-based activated carbon**

As an alternative to activated carbon, char from coconut fibres and from coconut pith has been developed. Coconut husk is a waste from coconut processing that is widely found in the tropical region.

Trials showed that the elemental mercury adsorption capacity of coconut pith is better than that of coconut fibres under the conditions of the trial. The adsorption capacity for elemental mercury of coconut pith char (3,142 µg/g) in these trials was much higher than of coal-based activated carbon (119 µg/g). This may indicate that activated char coals from CP may be a future potential source of adsorbents, which would replace the existing adsorbents, e.g., AC (Khairiraihanna et al. 2015).

#### *Co-benefits*

The use of waste such as coconut husk could provide economic benefits, in addition to reducing waste disposal problems due to reduced amounts of additives. Coconut char contaminated with mercury will still need to be disposed of properly.

## **5 BAT and BEP for waste incineration facilities**

### **5.1 Introduction to BAT for the incineration of waste**

The purpose of this section is to assist in the identification of the best techniques applicable to the process of waste incineration. BAT for waste incineration include the design, operation and maintenance of a waste incineration plant that effectively minimizes the emissions of mercury.

When considering the BAT for waste incineration, it is important to consider that the optimal solution for a particular type of incineration installation varies according to local conditions. The techniques provided here are not intended as a checklist indicating the best local solution, as this would require the consideration of local conditions to a degree that cannot be described in a document dealing with best available techniques in general. Hence, the simple combination of the individual elements described here as BAT, without consideration of local conditions, is not likely to give the optimized local solution in relation to the environment as a whole (European Commission 2006).

With a suitable combination of primary and secondary measures associated with BAT, mercury emission levels not higher than  $10 \mu\text{g}/\text{m}^3$  (at 11 per cent  $\text{O}_2$ ) have been reported (Daschner et al., 2011). It is further noted that under normal operating conditions emissions lower than  $1 \mu\text{g}/\text{m}^3$  can be achieved with a well-designed waste incineration plant (see section 5.5.2 below). There are many waste incinerator plants worldwide that are designed and operated according to most of the parameters defining BAT and that meet the associated emission levels. New plants could be expected to achieve these levels.

Small incineration installations, including medical waste incinerators, can pose problems in applying BAT. Some non-incineration techniques, as described in the Basel Convention ESM technical guidance for mercury waste (see section 3.7 of the present document) and section II of the Stockholm Convention guidelines on BAT and BEP may represent feasible and environmentally sound alternatives to incineration.

### **5.2 Pretreatment of waste before incineration**

The mixing (e.g., using bunker crane mixing) or further pretreatment (e.g., the blending of some liquid and pasty wastes, or the shredding of some solid wastes) of heterogeneous wastes to the degree required to meet the design specifications of the receiving installation is important. Pretreatment is most likely to be a requirement where the installation has been designed for a narrow specification, homogeneous waste.

### **5.3 BAT for waste input and control**

The following general practice for waste input and control should be considered when dealing with BAT for handling waste containing or contaminated with mercury:

- Maintain the site in a generally tidy and clean state;
- Establish and maintain quality controls over the waste input, according to the types of waste that may be received at the installation. This could include:
  - Establishing process input limitations and identifying key risks;
  - Communicating with waste suppliers to improve incoming waste quality control;
  - Controlling waste feed quality on the incinerator site;
  - Checking, sampling and testing incoming wastes.

### **5.4 BAT for waste incineration**

There is a potential trade-off to be made in operating waste incinerators. To achieve the highest-level destruction, the aim is complete combustion. The following section describes, first, the general considerations which are likely to lead to achieving maximum combustion. There then follows a description of particular considerations for individual waste streams. The selection of a combustion technique will depend on the type of waste to be incinerated.

#### **5.4.1 General conditions for combustion techniques**

The following conditions are important for achieving optimal combustion:

- Ensure that the furnace design is appropriately matched to characteristics of the waste to be processed;
- Maintain temperatures in the gas phase combustion zones in the optimal range for completing oxidation of the waste (for example,  $850 \text{ }^\circ\text{C}$ – $950 \text{ }^\circ\text{C}$  in grated municipal solid waste incinerators,  $1,100 \text{ }^\circ\text{C}$ – $1,200 \text{ }^\circ\text{C}$  when chlorine content of waste is high);

- Provide for sufficient residence time (e.g., at least two seconds) and turbulent mixing in the combustion chambers to complete incineration;
- Preheat primary and secondary air to assist combustion if necessary;
- Use continuous rather than batch processing wherever possible to minimize start-up and shutdown releases;
- Establish systems to monitor critical combustion parameters such as temperature, pressure drop, levels of CO and O<sub>2</sub> and, where applicable, grate speed;
- Provide for control interventions to adjust waste feed, grate speed, and temperature, volume and distribution of primary and secondary air;
- Install automatic auxiliary burners to maintain optimal temperatures in the combustion chambers;
- Use air from bunker and storage facilities as combustion air;
- Install system that automatically stops waste feeding when combustion parameters are not appropriate.

#### 5.4.2 Municipal solid waste incineration techniques

The following are considerations that are specific for the incineration of municipal solid waste:

- Mass burn (moving grate) incinerators are well demonstrated in the combustion of heterogeneous municipal solid waste and have a long operational history;
- Water-cooled grated incinerators have the added advantages of better combustion control and the ability to process municipal solid waste with higher heat content;
- Rotary kilns with grates can accept heterogeneous municipal solid waste but a lower throughput than the mass burn or moving grate furnaces;
- Static grated furnaces with transport systems (for example, rams) have fewer moving parts but waste may require more pretreatment (i.e., shredding, separation);
- Modular designs with secondary combustion chambers are widely used for smaller applications. Depending on size, some of these units may require batch operation;
- Fluidized bed furnaces and spreader or stoker furnaces are widely used for finely divided, consistent wastes such as refuse-derived fuel.

#### 5.4.3 Hazardous waste incineration techniques

The following are considerations that are specific for the incineration of hazardous waste:

- Rotary kilns are widely used for the incineration of hazardous waste and can accept liquids and pastes as well as solids (see subsections 2.2.3.13.1–2.2.3.5);
- Liquid injection incinerators are commonly used for hazardous waste incineration;
- Water-cooled kilns can be operated at higher temperatures and allow the acceptance of wastes with higher energy values;
- Waste consistency (and combustion) can be improved by shredding drums and other packaged hazardous wastes;
- A feed equalization system (for example, screw conveyors that can crush and provide a constant amount of solid hazardous waste to the furnace) will help ensure a continuous, controlled feed to the kiln and maintenance of uniform combustion conditions.

#### 5.4.4 Sewage sludge incineration techniques

The following are considerations that are specific for the incineration of sewage sludge

- Fluidized bed incinerators and multiple hearth incinerators are widely used for the thermal treatment of sewage sludge;
- Circulating fluid bed furnaces allow greater fuel flexibility than bubbling beds, but require cyclones to conserve bed material;
- Care must be exercised with bubbling bed units to avoid clogging;
- The use of heat recovered from the process to aid sludge drying will reduce the need for auxiliary fuel;
- Supply technologies are important in the co-incineration of sewage sludge in municipal solid waste incinerators. Demonstrated techniques include: dried sludge blown in as dust; drained sludge supplied

through sprinklers and distributed and mixed on the grate; and drained or dried sludge mixed with municipal solid waste and fed together (European Commission 2006).

#### 5.4.5 Medical waste incineration

The following are considerations that are specific for the incineration of medical waste

- Where grates are used, the design of the grate should incorporate sufficient cooling that it permits the variation of the primary air supply for the main purpose of combustion control, rather than for the cooling of the grate itself. Air-cooled grates with well distributed air cooling flow are generally suitable for wastes of net calorific value (NCV) of up to approximately 18 MJ/kg. Higher NCV wastes (e.g., above approximately 18 MJ/kg) may require water (or other liquid) cooling in order to prevent the need for excessive primary air levels to control grate temperature – i.e., levels that result in a greater air supply than the optimum for combustion control;
- Use should be made of a combustion chamber design that provides for containment, agitation and transport of the waste, such as rotary kilns – either with or without water cooling. Water cooling for rotary kilns may be favourable in situations where:
  - The NCV of the feed waste is higher (e.g., more than 15–17 GJ/tonne);
  - Higher temperatures – above 1,100 °C – are used (e.g., for slagging or destruction of specific wastes);
- Medical waste can be incinerated in municipal waste incinerators using the grate type of incinerator, although some special adaptations have to be made. If infectious medical waste is to be burnt in a municipal waste incinerator, it must be disinfected and sterilized beforehand or fed into the incinerator in appropriate containers by automatic loading (Stockholm Convention, 2008). The previous mixing of medical waste containing or contaminated with mercury with other waste types and direct handling should be avoided.

### 5.5 BAT for flue-gas treatment

In this subsection, techniques that could be considered in selecting BAT for the flue gas treatment of waste incineration plants are described. Unless otherwise stated, these are generally applicable for new and existing facilities. It also includes guidance on the upgrading of existing facilities.

FFs are commonly used, and have the advantage, when coupled with semi-dry or dry sorbent injection, they provide additional filtration and reactive surface on the filter cake. In combination with wet systems, ESPs can also be designed and operated to reach low mercury emissions. FFs have advantages in comparison with ESPs, especially when they are precoated with activated carbon for absorption of volatile pollutants; an additional advantage is good abatement directly after the start-up phase. Dry and semi-dry systems have the advantage of not requiring subsequent effluent treatment. The inlet temperature to the FF in such combinations is important. Temperatures above 130 °C–140 °C are normally required to prevent condensation and corrosion of the bags.

When using a dry system, the injection of activated carbon (which may also be impregnated with sorbents like sulfur, bromine or others), mixed with sodium hydrogen carbonate or calcium hydroxide upstream of a fabric filter can reduce the mercury emissions by more than 95 per cent. Effective and continuous maintenance of dust control systems is essential.

In the first stage of a high efficiency scrubber the removal efficiency of oxidized mercury as mercury (II) chloride – which is generally the main compound of mercury after waste combustion – is over 95 per cent. The overall mercury removal (both elemental and oxidized) efficiency is around 85 per cent.

As additional measure for minimizing mercury in the scrubbing water and avoiding re-emission of the soluble mercury, the precipitation of oxidized mercury with a suitable precipitating agent, e.g., sulfide, and the addition of activated carbon can be used.

Especially at low concentrations of halogens in the waste, bromine addition into the waste or boiler can lead to high oxidation rates of mercury, thereby improving the mercury removal in downstream control devices, e.g., scrubbers (see also section 3.4). The technique is mainly used in mono-combustion plants for sewage sludge and hazardous waste incineration plants.

With these applications, the concentration of mercury below 10 µg/m<sup>3</sup> (yearly average) has been reported (UNECE, 2013). In general, the use of fabric filters can give low levels within this emission range. With many wastes, adsorption using carbon-based reagents is generally required to achieve these emission levels. Some waste streams



have highly variable mercury concentrations and waste pretreatment may be required in such cases to prevent peak overloading of the flue gas treatment system capacity.

For wastes with high levels of mercury, such as hazardous or medical wastes, the combination of various flue gas treatment steps can be appropriate. For example, a scrubber with oxidation ingredients and activated carbon injection before a fabric filter can be used.

The most relevant secondary emission reduction measures are outlined in table 5. If the re-burn of flue gas treatment residues is applied, suitable measures should be taken to avoid the recirculation and accumulation of mercury in the installation.

SCR for the control of nitrogen oxides also reduces mercury emissions as a co-benefit by changing the mercury into a form that can be collected by FF or precipitated by wet scrubbers.

Pressure drop across fabric filters and flue gas temperature (if a scrubbing system is used upstream) should be monitored to ensure that filter cake is in place and bags are not leaking or being wetted.

Where temporary peak mercury concentrations are to be expected, the retention and injection of sulfur-impregnated activated carbon or coke should be considered as a safety precaution.

Reduction efficiencies depend on mercury input, concentrations in the raw gas and operating conditions.

**Table 5**

Control measures and reduction efficiencies for municipal, medical and hazardous waste incineration for stack gases

Control measure	Reduction efficiency
High efficiency scrubbers with ingredients in the scrubber liquor	> 85%
Scrubber + injection of bromine-containing chemicals into the combustion chamber	> 90%
Activated carbon injection + FF	> 95%

Source: European Commission 2006

### 5.5.1 Upgrading and improvement of existing treatment techniques

There are various options for upgrading exhaust gas treatment of existing plants. In systems equipped with an ESP, the ESP may be replaced by a fabric filter. In the flue gas stream ahead of the fabric filter, coke-based adsorbents (or substances with equivalent effects) have to be added to reduce mercury emissions. To minimize potential fire hazards a mixture with limestone reagents may be used.

In case of high mercury emissions at facilities equipped only with a scrubber, a combination of additive injection, with fabric filters, can be installed downstream.

Both measures have the added benefit that acidic and organic pollutants can also be removed from the flue gas. Owing, however, to increased fire hazards, the addition of a static-bed filter with activated carbon or lignite coke requires additional security measures.

### 5.5.2 Performance levels associated with the use of BAT

With the combination of techniques described in section 5.5, mercury concentrations in the clean gas no higher than 10 µg/m<sup>3</sup> have been reported. The figure and the tables in section 3.6 show that at almost all installations concentrations below 10 µg/m<sup>3</sup> can be achieved, in particular when activated carbon is used in combination with other techniques. Some plants in Europe and Japan show mercury concentrations below 1 µg/m<sup>3</sup> when activated carbon is used.

## 5.6 Introduction to BEP

Best environmental practices (BEP), as defined in the Minamata Convention, means the application of the most appropriate combination of environmental control measures and strategies. The following graduated range of measures should be considered in applying BEP:

- Regulatory infrastructure with sufficient capacity to permit incinerators, control and monitor mercury emissions regularly;

- Provision of information and education to the public, users and decision makers about the environmental consequences of choice of particular activities and choice of products, and ultimate disposal;
- Development and application of codes of good environmental practice, which covers all aspects of the activity in the product's life;
- Application of labels to guide those handling the waste stream to direct components to proper treatment;
- Application of labels informing consumers of environmental risks, enabling them to make informed decision about choice;
- Use of resources, including energy;
- Integrating waste collection and disposal systems into residential, commercial and industrial processes to ensure that all waste is managed in an environmentally sound manner;
- Avoiding the use of hazardous substances or products that contain hazardous substances and the generation of hazardous waste;
- Recycling, recovery and reuse;
- Application of economic instruments, systems of licencing, restrictions, bans, certifications, standards or other policy tools;
- Evaluation of the mercury life cycle as an important perspective for the ESM of mercury wastes, in the effort to reduce mercury input into the waste incineration process (see Basel Convention technical guidelines).
- Recognizing importance of public participation in permitting processes. Effective practices for improving public awareness and involvement include: placing advance notices in newspapers; distributing information to area households; soliciting comments on the design and operational options; providing information displays in public spaces; maintaining pollutant release and transfer registers; and holding frequent public meetings and discussion forums. Authorities and proposers of incineration projects should engage with all stakeholders, including the public interest groups. Consultations with the public must be transparent, meaningful and sincere if they are to be effective.

### **5.6.1 Waste management practices**

The approaches outlined below, must be taken into account as part of overall waste prevention and control strategies for mercury containing or contaminated waste.

To be sustainable, waste management cannot be solved only with technical end-of-pipe solutions; instead an integrated approach is necessary. This may be described as a hierarchical approach, as set out in section 2.1.1. Waste contaminated with or containing mercury should be dealt with according to Article 11 of the Convention.

#### **5.6.1.1 Waste minimization**

Reducing the overall mass of wastes that have to be disposed of by any means serves to reduce both the releases and residues from incinerators.

#### **5.6.1.2 Source separation and recycling**

In many industrialized countries, health care institutions have begun to phase-out mercury uses and phase-in effective alternative products or devices that avoid the use of mercury. A co-benefit of mercury-free alternatives is a reduction of the generation of mercury-containing waste. Many health care institutions have also instituted housekeeping and management practices to improve the control of mercury releases from sources still present in their facilities. Such policies and practices substantially decrease emissions and releases of mercury to the environment. Source separation and recycling represent an important part of an integral approach to waste management in the health care sector that leads to minimization of hazardous waste requiring special treatment due to its infectious properties as demonstrated in table 6 (Emmanuel, 2012).

Level of Segregation	% Hazardous Healthcare Waste	% General Non-Risk Waste
Poor	60	40
Fair	25	75
Rigorous	15	85

Source: Emmanuel (2012)

**Table 6. Typical classifications depending on separation practice.**

Efforts to prevent the inclusion of mercury in waste inputs will help to reduce overall mercury emissions from incineration. Measures to exclude mercury from waste inputs are therefore of special importance. These could include such measures as the separate collection systems or proper classification of waste at all stages before incineration, and the separation of waste at the facilities as a primary technique.

The separate collection of waste streams which could potentially be contaminated with high amounts of mercury, and the diversion of mercury containing waste to environmentally sound management facilities could lead to a significant reduction of the mercury content in the waste going to incineration. There could be separate collection for the following wastes:

- Mercury-containing batteries;
- Mercury-containing lamps;
- Electrical devices (switches and others) that contain mercury;
- Potentially contaminated waste from households and municipal institutions (old paint and varnish, insecticides, solvents, used laboratory chemicals from schools, etc.).

#### 5.6.1.3 Waste inspection and characterization before incineration

The following general practice for waste input and control should be considered when identifying the BAT for handling waste containing or contaminated with mercury. When establishing and maintaining quality controls over the waste input, according to the types of waste that may be received at the installation, it is important to establish process input limitations and identify key risks, and also to communicate with waste suppliers to improve incoming waste quality control.

A thorough knowledge of the characteristics and attributes of the incoming waste is essential. The characteristics of a particular waste stream may vary significantly from country to country and region to region. If certain wastes or waste constituents are considered inappropriate for incineration, such as waste included in Article 11 of the Convention, procedures should be in place for detecting and separating these materials in the waste stream or residues prior to incineration unless the waste is intended for thermal treatment to recover mercury as described in the technical guidance for the ESM of mercury waste issued by the Basel Convention. Inspection, sampling and analyses should be performed as a matter of routine. This is particularly true for hazardous wastes. It is vital that manifests and audit trails be maintained and kept updated. Table 7 illustrates some of the techniques applicable to the different types of waste.

**Table 7**

Examples of inspection techniques (EC 2006)

Waste type	Techniques	Comments
Mixed municipal wastes	Visual inspection in bunker Spot checking of individual deliveries by separate offloading Weighing the waste as delivered Periodic sampling and analysis for key properties or substances	Industrial and commercial loads may have elevated risks
Pretreated municipal wastes and refuse-derived fuels	Visual inspection Periodic sampling and analysis for key properties or substances	
Hazardous wastes	Visual inspection Sampling and analysis of all bulk tankers	Extensive and effective procedures are

<i>Waste type</i>	<i>Techniques</i>	<i>Comments</i>
	Random checking of drummed loads Unpacking and checking of packaged loads Assessment of combustion parameters Blending tests on liquid wastes prior to storage Control of flashpoint for wastes in the bunker Screening of waste input for elemental composition, for example by EDXRF <sup>a</sup>	particularly important for this sector. Plants receiving monostreams may be able to adopt more simplified procedures
Sewage sludges	Periodic sampling and analysis for key properties and substances Process control to adapt to sludge variation	

<sup>a</sup> EDXRF: energy dispersive X-ray fluorescence (spectrometer).

#### **5.6.1.4 Removal of non-combustibles at the incinerator**

The removal of both ferrous and non-ferrous metals on site is a common practice at municipal solid waste incinerators and helps to prevent these wastes, which may contain mercury as an impurity, from entering waste incineration.

#### **5.6.1.5 Proper handling and storage**

Proper handling, particularly of hazardous waste, is essential and appropriate sorting and segregation should be undertaken to enable safe processing.

Storage areas must be properly sealed with controlled drainage and weatherproofing. Fire detection and control systems for these areas should also be considered, along with adequate capacity to retain contaminated fire water onsite. Storage and handling areas should be designed to prevent the contamination of environmental media and to facilitate clean-up in the event of spills or leakage. Odours and release of volatile persistent organic pollutants to environmental media can be minimized by using bunker air for the combustion process.

#### **5.6.1.6 Minimizing storage times**

Although having a constant supply of waste is important for continuous operation and stable firing conditions in large municipal solid waste incinerators, the accumulation and storage of a given waste for a long period of time is undesirable. Minimizing the storage period will help prevent putrefaction and unwanted reactions, and the deterioration of containers and labelling. Managing deliveries and communicating with suppliers will help ensure that reasonable storage times (e.g., four to seven days for municipal solid waste) are not exceeded.

#### **5.6.1.7 Waste loading**

For facilities that accept heterogeneous municipal solid waste, proper mixing and loading of the feed hopper is critical. Loading-crane operators must have the experience and the appropriate vantage point to be able to select the appropriate mix of waste types to keep the incinerator performing at peak efficiency.

The approach to BEP for incinerating wastes containing or contaminated with mercury are captured under the following:

- Waste prevention before incineration;
- Incinerator operating and management practices;
- Post incineration operating and management practices.

#### **5.6.1.8 Incinerator operating and management practices**

Proper operation is critical to achieving design parameters. In general, the manufacturer or designer of the equipment should provide a manual that discusses operating practices, including start-up procedures, shutdown procedures, normal operation, troubleshooting, maintenance procedures, recommended spare parts and others. Operators must be able accurately to predict the heating value and other attributes of the waste being combusted in order to ensure that the design parameters of the incinerator are being met. This can be done using the results from a feed monitoring programme of key contaminants and parameters where sampling and analysis frequencies and rigour would increase as feed variability increases. Detailed information may be found in subsections 2.2.3.1–2.2.3.5 above.

### **5.6.1.9 Site selection of an incinerator plant**

The location of an incinerator can significantly affect dispersion of the plume from the chimney, which in turn affects ambient concentrations, deposition and exposures to workers and the community. In addition to addressing the physical factors affecting dispersion, siting must also address issues of permissions and ownership, access and convenience and take into account social, health and other environmental impacts. Best practice siting has the goal of finding a location for the incinerator that minimizes potential risks to public health and the environment (EPA 1997).

#### **5.6.1.10 Design**

Adequate plans, drawings and quality control are essential in the construction of incinerators. These must include dimensional drawings, tolerances, material lists and other preparatory studies. Through such proper design and operation, incinerators should be able to achieve desired temperatures, residence times, and other conditions necessary to minimize the emission of mercury into the environment, avoid clinker formation and slagging of the ash (in the primary chamber), avoid refractory damage, and minimize fuel consumption.

#### **5.6.1.11 Regular facility inspections and maintenance**

Routine inspections by the operator and periodic inspections by the relevant authority of the furnace and air pollution control devices should be conducted to ensure system integrity and the proper performance of the incinerator and its components. Regardless of how well equipment is designed, wear and tear during normal use and poor operation and maintenance practices will lead to the deterioration of components, a resultant decrease in both combustion quality, an increase in emissions, and potential risks to the operator and public.

#### **5.6.1.12 Operator training**

Regular training of personnel is essential for good operation of waste incinerators. Proper operation of incinerators is necessary to minimize emissions and other risks. Only a trained and qualified operator should operate or supervise the incineration process. The operator must be on site while the incinerator is operating. Without proper training and management support, incinerators cannot achieve proper treatment and acceptable emissions.

### **5.6.2 Prevention of fire risks**

At waste incineration plants, fires in the waste bunker can cause significant pollution, e.g., mercury and other heavy metals, hazardous organic compounds, etc., in the vicinity of the plant. To minimize the risk of such fires the following measures could be considered as BEP:

- Use of automatic fire detection systems in waste bunkers, e.g., infrared cameras
- Installation of redundant monitors in waste bunkers
- Use of automatic fire detection systems for fabric and static bed coke filters, e.g., temperature control, electrical and control rooms, and other identified risk areas, e.g., smoke alarms
- Automatic fire control systems, e.g., with inert gas. Such measures are applied in some cases, most commonly when storing flammable liquid waste but also in other risk areas
- Provision of sufficient amounts of extinguishing water
- Sufficient retaining of extinguishing water
- Sufficient flue openings for smoke and heat (closed at normal operating conditions)
- Sufficient openings in the bunker walls for an extinction charge in case of fire (closed at normal operating conditions)
- Option to circle the incineration plant for the fire service

## 6 Mercury monitoring techniques

General and cross-cutting aspects of testing, monitoring and reporting are discussed in the introductory chapter of this document. Specific aspects inherent to waste incineration processes will be discussed in the following section.

### 6.1 Direct methods

Direct mercury measurements can be carried out either continuously or discontinuously.

#### Continuous emission monitoring systems (CEMS)

The advantage of continuous monitoring is that it helps ensure the proper functioning of the flue gas treatment installation and the early detection of any change in the mercury content in the waste.

Despite measures to control or minimize the input of mercury in waste incineration plants, significant amounts of mercury are still occasionally able to pass through the waste bunker into the combustion and thus into the flue gas and therefore to vary the level of mercury emissions.

With the help of continuously operating mercury measuring devices, such contamination can be recognized and countermeasures initiated quickly as needed. Figure 9 shows the variation within one year of mercury concentration in the clean gas of a waste incineration plant in Hamburg. Distinct peaks can be seen, in particular in the months of October and November.

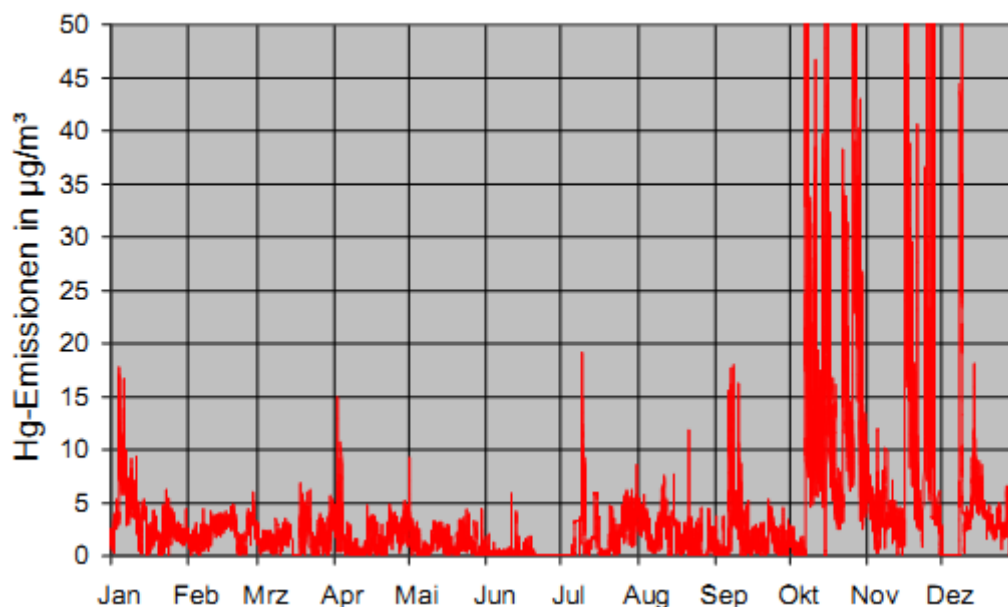

**Figure 9** Mercury emission data of one line of a waste incineration plant in Hamburg in 2014

In some countries, the majority of the waste incineration plants are equipped with continuous operating devices. If elevated levels of mercury are detected in the flue gas, countermeasures can be initiated. These include, for example, the following:

- Increasing the injected amount of sorbents into the flue gas stream;
- Use of sulfur-predoped activated carbon with an increased reduction efficiency for mercury;
- Adding bromine to the combustion to enhance the oxidation of mercury.

If very high level of mercury is detected in hot spots in the waste, these hot spots should be evacuated. In the event of elevated mercury levels in the flue gas cleaning system, cleaning of the flue gas to remove mercury should be considered.

When elevated emission levels are observed the facility operator should check the monitoring and operating systems to determine the cause and take corrective actions. The operator should also monitor inputs and inform the waste deliverers about the input monitoring. Such measures are found to be effective in most cases, and lead to a significant decline in the number of exceedances.

CEMS are sometimes used to sample the particulate laden gas stream before a particulate control device (see 3.3). That makes possible an immediate response, e.g., by injecting activated carbon or halogenated compounds.

### **Stationary source measurement (impinger)**

The use of impinger methods for mercury monitoring in waste incineration plants has historically been the preferred option. Owing to the complexity and cost of this method, impinger sampling is carried out less frequently, often only quarterly or annually. Stationary source measurement by impinger of a proper function of the flue gas treatment installation is only possible during short sampling periods. The detection of mercury peaks in the flue gas is commonly not possible and, therefore, no countermeasures can be initiated. Impinger methods are not appropriate, however, for long sampling periods and in practice are limited to several hours.

### **Sorbent trap systems**

Sorbent trap systems make possible surveillance of the proper functioning of the flue gas treatment installation after a sampling period. While sorbent trap systems do not provide real-time results, the data obtained can indicate the operating performance over the previous set time period. With this feedback loop approach, adjustments to the process can then be made as needed. Compared to the impinger methods, sorbent traps provide more stable mercury retention and a simpler sampling protocol. The simpler sampling protocol allows for unattended operation of the monitoring over extended periods, which is not possible with the impinger methods.

This system is not commonly used in the European Union, because there are no legal requirements for its use. It is possible, however, that it is used in other regions of the world.

## **6.2 Indirect methods**

### **Mass balances**

Mass balances are extremely difficult to apply, owing to potentially high mercury variations in waste input and the extreme difficulty of reliably monitoring mercury levels in heterogeneous waste.

### **Predictive emissions monitoring**

Predictive emissions monitoring (parametric monitoring) is not possible at waste incineration plants since there is no relation between other pollutants and mercury in the flue gas. Added to which, mercury content in furnace feedstocks can change significantly over short periods, depending on the concentration of the mercury in the waste.

### **Emission factors**

For monitoring purposes, emission factors should not be used for determining mercury emissions from waste incineration plants, because of the variable mercury content in waste.

### **Engineering estimates**

Engineering estimates are not an accurate method of mercury air emission monitoring for waste incineration plants.

## **6.3 Most appropriate techniques for monitoring in the waste incineration sector**

Both continuous and discontinuous monitoring are considered to form part of BAT implementation.

Continuous measurements are suitable for various reasons. Notably, they enable:

- Monitoring of the proper functioning of the flue gas treatment installation;
- Prompt detection of changes in the mercury content in the waste;
- Detection of high concentrations of mercury due to improper input of contaminated waste.

Several countries already require continuous monitoring of mercury at their waste incineration installations. They consider techniques for continuous monitoring as BAT. The majority of countries conducting mercury monitoring use discontinuous monitoring, e.g., impinger sampling.

Only continuous monitoring ensures that elevated mercury levels in cleaned gas and raw gas are detected for effective control. In such cases a sorbent may be used, e.g., sulfur-doped activated carbon.

In particular for hazardous waste, medical waste, mixed commercial and municipal waste, and also for all other waste types (including illegal entries) when it cannot be guaranteed that they contain no mercury, continuous measurement of mercury may be the most effective method.

Discontinuous measurement methods are also applicable. Sorbent trap systems and stationary source testing (impinger) monitoring make possible surveillance of the proper functioning of the flue gas treatment installation during the sampling periods. With these discontinuous measurement methods, the detection of high mercury levels in the flue gas is unlikely and, therefore no countermeasures can be initiated.

Indirect methods, such as mass balances, predictive emission monitoring, emission factors and engineering estimates, are not useful as measurement methods for waste incineration plants.



## 7 References

- Adam, F., et al. (2010). KVA-Rückstände in der Schweiz – Der Rohstoff mit Mehrwert- Bundesamt für Umwelt (BFU), Bern.
- Allen, C., V. Gokaldas, A. Larracas, L. A. Minot, M. Morin, N. Tangri, B. Tyler and B. Walker (2012). On the Road to Zero Waste: Successes and Lessons from around the World. Berkeley, GAIA, p. 88.
- Andersson, S., P. Lindgren (2010). Simultaneous Dioxin and Mercury Removal in Wet Scrubbers (Paper # 56), Air and Waste Management Association -PUBLICATIONS- VIP THEN CP; p .189; pp. 515–524
- APGEN (Applied PhytoGenetics) (2003). Letter from David Glass, APGEN, to Walter Kovalick, EPA Technology Innovation Office (TIO), regarding the field study of Eastern cottonwood trees to treat mercury contaminated soil at a Superfund site in Danbury, Connecticut.
- Basel Convention Secretariat. (2015). Technical Guidelines on the Environmentally Sound Management of wastes consisting of, containing or contaminated with mercury and mercury compounds. Basel Convention on the Control of Transboundary Movements of Hazardous Wastes and Their Disposal, UNEP, Geneva
- Bell, L. (2015). Identification and Management of mercury, PCB and dioxin contaminated sites in Kazakhstan: A Collective Impact approach to civil society engagement. Contaminated sites and their management. Case studies: Kazakhstan and Armenia. Prague-Karaganda, Arnika - Toxics and Waste Programme.  
<http://english.arnika.org/contaminated-sites>
- Bittig, M., and S. Heap (2014). Maßnahmen zur Minderung luftseitiger Emissionen unter besonderer Berücksichtigung von Quecksilber, Feinstaub und Stickoxiden, Energie aus Abfall, Band 11.
- Bilitewski, B., C. Oros and T. H. Christensen (2010). Mechanical Biological Treatment. Solid Waste Technology and Management, John Wiley and Sons, pp. 628–638.
- Bühler, A., et al. (2015). Schwermetalle aus der Flugasche zurückgewinnen – saure Flugaschewäsche – FLUWA-Verfahren – ein Zukunftsweisendes Verfahren in der Abfallverbrennung,  
<http://www.bsh.ch/upload/public/0/71/BSH-Umweltservice-AG-Saure-Flugaschenwaesche-FLUWA-Verfahren.pdf>.
- BSH (2015). BSH Umwelt Service AG – Quecksilber-Abscheidung.  
<http://www.bsh.ch/upload/public/0/71/BSH-Umweltservice-AG-Selektive-Quecksilber-Ionentaucher.pdf>.
- Chaucherie, X., et al. (2014). Mercury abatement at two French rotary kiln hazardous waste incineration plants with mainly dry flue gas cleaning, VDI Conference, 15–16 April 2014 in Düsseldorf, Germany.
- Daschner, R., et al.: Emissionen und Abgasreinigungsverfahren bei der Abfallverbrennung, Technische Sicherheit Bd. 1 (2011) Nr. 1/2 Jan./Febr. Emission Control – Thermal Waste Treatment – Fundamentals – VDI 3460 Part 1, Kommission Reinhaltung der Luft im VDI und DIN – Normkontrollausschuss KRdL; VDI/DIN-Handbuch Reinhaltung der Luft, and 3: Emissionsminderung II VDI Handbuch Energietechnik.
- Emmanuel, J. (2012). Compendium of Technologies for Treatment/Destruction of Healthcare Waste. Osaka, UNEP DTIE: 225.
- European Commission (2006). Integrated Pollution Prevention and Control (IPPC) Reference Document on Best Available Techniques for Waste Incineration, July 2005, Seville, Spain, [eippcb.jrc.es/pages/FActivities.htm](http://eippcb.jrc.es/pages/FActivities.htm).
- European Commission (2000). Waste Incineration Directive 2000/76/EC.
- European Commission (2010). Industrial Emissions Directive 2010/75/EU.
- European Commission (2013). Best Available Techniques (BAT) Reference Document for the Large Combustion Plants Draft 1 (June 2013) Joint Research Centre – Institute for Prospective Technological Studies Sustainable Production and Consumption Unit European IPPC Bureau, Seville, Spain.

- Esser-Schmittman, W. (2012). Quecksilberabscheidung aus Feuerungsprozessen mittels Chemisorption an Aktivkohle und anderen Sorbentien. Berliner Planungs- und Immissionsschutzkonferenz am 19. und 20. November 2012.
- Federal Remediation Technologies Reference Guide and Screening Manual, Version 4.0. 2004. *In Situ* Biological Treatment – Phytoremediation. Federal Remediation Technologies Roundtable. June 2004. <http://www.frtr.gov/matrix2/section4/4-3.html>.
- Fundamentals – VDI 3460 Part 1, Kommission Reinhaltung der Luft im VDI und DIN – Normkontrollausschuss KRdL; VDI/DIN-Handbuch Reinhaltung der Luft, and 3: Emissionsminderung II VDI Handbuch Energietechnik
- Galbreath, K.C., and C. Zygarlicke (1996). Mercury speciation in coal combustion and gasification flue gases. *Environmental Science and Technology* 30, pp. 2421–2426.
- Gebhardt, P. Quecksilberemissionen durch die Müllverbrennung, Ingenieurbüro für Umweltschutztechnik, Salzburg, September 2005.
- GORE™ Mercury Control System, Overview, February 2014.
- Greyson, J. (2007). An economic instrument for zero waste, economic growth and sustainability. *Journal of Cleaner Production* 15 (13–14): pp.1382–1390.
- Hall, B., P. Schager and O. Lindqvist (1991). Chemical Reactions of Mercury in Combustion Flue Gases. *Water, Air and Soil Pollution*, 56, pp. 3–14.
- Health Care Without Harm (2001). *Non-Incineration Medical Waste Treatment Technologies*. Health Care Without Harm. Washington D.C., 118 pp.
- Health Care Without Harm Europe (2004). *Non-Incineration Medical Waste Treatment Technologies in Europe*. Health Care Without Harm Europe. Prague, 44 pp.
- Heaton, A.C.P., C.L. Rugh, T. Kim, N.J. Wang and R.B. Meagher (2003). Toward detoxifying mercury-polluted aquatic sediments with rice genetically engineered for mercury resistance. *Environmental Toxicology and Chemistry* 22 (12), pp. 2940–2947.
- Hubbard, J., S. Tsadwa, N. Willis, and M. Evans (1990). Site Sampling and Treatability Studies for Demonstration of WasteChem’s Asphalt Encapsulation Technology Under EPA’s SITE Program. *Journal of the Air Waste Management Association* 40(10), pp.1436–1441.
- ITRC (1998). *Technical Guidelines for On-site Thermal Desorption of Solid Media and Low Level Mixed Waste Contaminated with Mercury and/or Hazardous Chlorinated Organics*. The Interstate Technology and Regulatory Cooperation Work Group – Low Temperature Thermal Desorption Work Team, 68 pp.
- Kalb, P.D., and P. Colombo (1997). *Composition and Process for the Encapsulation of Radioactive Hazardous and Mixed Wastes*. United States Patent 5,649,323.
- Kalogirou, E. (2012). The development of WtE as an integral part of the sustainable waste management worldwide, Recuwatt Recycling and Energy Conference, Mataró, Spain, 4 October 2012.
- Kalb, P.D., D. Melamed, B.R. Patel and M. Fuhrmann (2002). *Treatment of Mercury-Containing Wastes*. United States Patent 6,399,849.
- Keiser, B.; Glesmann, S.; Taff, B.; Senior, C.; Ghorishi, Behroos, Mimna, Richard; Miller, J.; Byrne, H. (2014): Improving Capture of Mercury Efficiency of WFDGs by reducing Mercury Reemissions, Institute of Clean Air Companies (ICAC), 6/2014. <http://www.greatlakes.com/deployedfiles/ChemturaV8/GreatLakes/GeoBrom/GeoBrom%20Brochures/ICAC%20Improving%20Capture%20of%20Mercury%20Efficiency%20of%20WFDGs.pdf>.

- Khairiraihanna et al. (2015). Removal performance of elemental mercury by low-cost adsorbents prepared through facile methods of carbonisation and activation of coconut husk; *Waste Management and Research* 2015, vol. 33(1), pp. 81–88.
- Klaist: Vorbeugender chemischer Holzschutz in: Johann Müller (Hrsg.): *Holzschutz im Hochbau. Grundlagen – Holzschädlinge – Vorbeugung – Bekämpfung*. Fraunhofer IRB Verlag, Stuttgart 2005.
- Licata, A., et al. (2007). Safety aspects in the use of carbonaceous sorbents during waste gas treatment, *Metallurgical Plant and Technology* 3, pp. 144–152.
- Looney, B.B., et al. (2001). Ultralow Concentration Mercury Treatment Using Chemical Reduction and Air Stripping. WSRC-MS-2001-00388. 24 April 2001.
- Mattigod, S.V., G. Fryxell, R. Skaggs, K. Parker, J. Liu and X Feng (2003). Mercury Removal from Waste Streams Using a Novel Synthetic Nanoporous Sorbent. Industrial Water Conference. Las Vegas, Nevada, United States, December 2003.
- Löthgren, C.-J., et al. (2007). Mercury Speciation in Flue Gases after an Oxidative Acid Wet Scrubber, *Chemical Engineering and Technology*, 30(1), pp. 131–138.
- Marsan, R. et al. 2012: Maintaining High Level Mercury Capture in wFGD Absorber, *STEAG Energy Services LLC*. APC Round Table Expo Presentation. Reinhold Environmental Ltd. Baltimore, 16./17.7.2012.
- Meng, X., Z. Hua, D. Dermatas, W. Wang and H.Y. Kuo (1998). Immobilization of mercury (II) in contaminated soil with used tire rubber. *Journal of Hazardous Materials*. 57, pp. 231–241.
- Miller, C.M., S.E. Duirk and K.H. Gardner (2000). Chromium leaching from a silicone foam-encapsulated mixed waste surrogate. *Environmental Science and Technology* 34(3), pp. 455–460.
- Miller et al (2014). Mercury Control with Brominated PAC and Injection Upstream of a WET FGD System. Presented at the Power Plant Pollutant Control “MEGA” Symposium, 19–21 August 2014, Baltimore, United States.
- Mineur, M., et al. Betriebliche Erfahrungen zur Minderung von Quecksilberemissionen bei der Hausmüllverbrennung VDI Wissensforum, Oktober 2012, Würzburg, Germany.
- Muenhor, D., et al (2009). Mercury contamination and potential impacts from municipal waste incinerator on Samui Island, Thailand, *Journal of Environmental Science and Health. Part A, Toxic/Hazardous Substances and Environmental Engineering*, March, 44, pp. 376–387.
- Material Safety Data Sheet according to EU Directive 1907/2006/EC, Article 31 on PRAVO
- Nethe, L.-P.. Optimierung der Quecksilberabscheidung in der Rauchgasreinigung von Verbrennungsanlagen durch den Einsatz schwefelhaltiger Zusatzkomponenten, Texocon Potsdam, January 2009.
- Nishitani, T., et al. (1999). The relationship between HCl and mercury speciation in flue gas from municipal solid waste incinerators. *Chemosphere*, 39, (I), pp. 1–9.
- Orebaugh, E.G. 1993. Lead Macroencapsulation Conceptual and Experimental Studies. WSRC-RP-93-227. Aiken, SC, Westinghouse Savannah River Company, January 1993.
- Owens, M.; Goltz, H. R.; Mingee, D.; Kelly, R. (2011): Trace Mercury Removal from Flue Gas Desulfurization Wastewater. Degremont Technologies, Dow Chemical Company, Degremont North American Research & Development, Internetpublikation, 5.5.2011, 5.5.2011. [http://www.degremont-technologies.com/IMG/pdf/tech\\_infilco\\_FGD-Mercury.pdf](http://www.degremont-technologies.com/IMG/pdf/tech_infilco_FGD-Mercury.pdf).
- Petrlik, J., and R. Ryder (2005). After Incineration: The Toxic Ash Problem. Prague, Manchester, IPEN Dioxin, PCBs and Waste Working Group, Arnika Association, 59 pp. [http://english.arnika.org/files/documents/ASH\\_report.pdf](http://english.arnika.org/files/documents/ASH_report.pdf)
- Pless-Mullooli, T., R. Edwards, O. Pöpke and B. Schilling (2001). Report on the analysis of PCDD/F and heavy metals in soil and egg samples from Newcastle allotments: Assessment of the role of ash from Byker incinerator, 50 pp.

Reinhold Environmental Ltd. 2012. Maintaining high level mercury capture in wFGD Absorber. 2012 APC Round Table & Expo Presentation, 16–17 July 2012 in Baltimore, United States.

Riethmann, Thomas (2013): Untersuchungen zur Sorption von Quecksilber aus Verbrennungsabgasen und Nebenprodukten in Entschwefelungsanlagen. *Dissertation am Institut für Feuerungs- und Kraftwerkstechnik, Universität Stuttgart*. Shaker Verlag. Aachen. 11/2013.

<http://www.shaker.de/de/content/catalogue/index.asp?lang=de&ID=8&ISBN=978-3-8440-2302-2>,

Robles, I., M.G. García, S. Solís, G. Hernández, Y. Bandala, E. Juaristi, and E. Bustos (2012). Electroremediation of mercury polluted soil facilitated by complexing agents. *International Journal of Electrochemical Science*, 7, pp. 2276–2287.

Sahu, S.K., R.C. Bhangare, P.Y. Ajmal, S. Sharma, G.G. Pandit, and V.D. Puranik (2009). Characterization and quantification of persistent organic pollutants in fly ash from coal fueled thermal power stations in India. *Microchemical Journal* 92, pp. 92–96.

Schager, P. Report No. FBT-91-20, Status energiverk, National Energy Administration Sweden, 1990.

Schmid (2014). Information provided by Susanne Schmidt, Stadtentwässerung Frankfurt, on 10 October 2013.

Schneidereit, D. (2014): Pilotanlage – Versuchsergebnisse – Kraftwerk Heyden - Wasserrecht 2013 – Erweiterung Pilotanlage; bereitgestellt per E-mail an C. Tebert von Bezirksregierung Detmold, 28.4.2014.

SEF (2013). Description of the sewage sludge incineration plant in Frankfurt Sindlingen

<http://www.stadtentwaesserung-frankfurt.de/index.php/anlagen/abwasserreinigung/sewa-sindlingen.html?limitstart=0>

Shaheen, S.M., P.S. Hooda and C.D. Tsadilas (2012). Opportunities and challenges in the use of coal fly ash for soil improvements: A review. *Journal of Environmental Management* 145, pp. 249–267.

Siebert, J. (2005). An Examination of Using In-Situ Thermal Desorption to Remediate Mercury Contaminated Soils Through Laboratory Experiments and Numerical Modeling. Masters Thesis. University of Texas at Austin, United States, May 2005.

Skinner, K., et al. (2007). Mercury uptake and accumulation by four species of aquatic plant. *Environmental Pollution* 145, pp. 234–237.

Smith, L.A., J.L. Means, A. Chen, B. Alleman, C.C. Chapman, J.S. Tixier, S.E. Brauning, A.R. Gavaskar, and M.D. Royer (1995). *Remedial Options for Metals-Contaminated Sites*. Lewis Publishers, Boca Raton, United States.

Snowman Network BRGM (2014). Enhanced knowledge in mercury fate and transport for improved management of Hg soil contamination.

Song, G.-J., et al. (2004). Characteristics of ashes from different locations at the MSW incinerator equipped with various air pollution control devices. *Waste Management* 24(1), pp. 99–106.

Stockholm Convention (2008) Guidelines on Best Available Techniques and Provisional Guidance on Best Environmental Practices relevant to Article 5 and Annex C of the Stockholm Convention on Persistent Organic Pollutants; Section V Guidance/guideline by source category; Source categories in Part II of Annex C Part II Source category (a) Waste Incinerators.

Takaoka, M., et al. (2002). Control of mercury emissions from a municipal solid waste incinerator in Japan, *Journal of the Air and Waste Management Association*, 52, pp. 931–940.

Takaoaka, M., et al. (2012). Mercury emission from sewage sludge incineration in Japan, *Journal of Material Cycles and Waste Management* 14, pp. 113–119.

United States Department of Energy (1998). Innovative Technology Summary Report. Plasma Hearth Process at the Science and Technology Research (STAR) Center, Idaho Falls, Idaho. November 1998.

<http://costperformance.org/pdf/itsr26.pdf>.

- United States Environmental Protection Agency (EPA), Office of Research and Development (1997). Engineering Bulletin, Technology Alternatives for the Remediation of Soils Contaminated with Arsenic, Cadmium, Chromium, Mercury, and Lead. Cincinnati. EPA-540-S-97-500. March.  
<http://www.epa.gov/clariton/clhtml/pubtitleOSWER.html>.
- United States Environmental Protection Agency (EPA) (2005). Technical Support Document for HWC MACT Standards Vol. 1 Description of Source Categories, Washington D.C., September 2005.
- United States Environmental Protection Agency (EPA), Office of Research and Development (2004). Minergy Corporation Glass Furnace Technology Evaluation Report. EPA/540/R-03/500. March.  
[http://costperformance.org/pdf/20040702\\_353.pdf](http://costperformance.org/pdf/20040702_353.pdf).
- United States Environmental Protection Agency (EPA) (1995). Superfund Innovative Technology Evaluation (SITE) Technology Capsule, Geosafe Corporation In Situ Vitrification Technology. Office of Research and Development. EPA/540/R-94/520. March. [http://www.epa.gov/ORD/SITE/reports/540\\_r94\\_520.pdf](http://www.epa.gov/ORD/SITE/reports/540_r94_520.pdf).
- United States Environmental Protection Agency (EPA), Office of Solid Waste and Emergency Response (2002). Arsenic Treatment Technologies for Soil, Waste, and Water. EPA-542-R-02-004. September 2002.
- United Nations Economic Commission for Europe (UNECE) (1998). Protocol to the 1979 Convention on Long-range Transboundary Air Pollution on Persistent Organic Pollutants. New York and Geneva.  
[www.unece.org/env/lrtap/full%20text/1998.POPs.e.pdf](http://www.unece.org/env/lrtap/full%20text/1998.POPs.e.pdf).
- United Nations Economic Commission for Europe (UNECE) (2013). Convention on Long-range Transboundary Air Pollution, Guidance document on best available techniques for controlling emissions of heavy metals and their compounds from the source categories listed in annex II to the Protocol on Heavy Metals, UN ECE/EB.Air/116, July 2013.
- United Nations Environment Programme (UNEP) (2005). Basel Convention Technical Guidelines: General technical guidelines for the environmentally sound management of wastes consisting of, containing or contaminated with persistent organic pollutants (POPs).
- Velis, C. A., P. J. Longhurst, G. H. Drew, R. Smith and S. J. T. Pollard (2009). Biodrying for mechanical–biological treatment of wastes: A review of process science and engineering. *Bioresource Technology* 100(11), pp. 2747–2761.
- Vosteen, B., et al. Bromine-enhanced mercury abatement from combustion flue gases – recent industrial applications and laboratory research, *VGB Power Tech* Volume 86, Issue 3/2006.
- De Vries, W., et al (2007). Critical soil concentration of cadmium, lead and mercury in view of health effects on humans and animals. *Reviews of Environmental Contamination and Toxicology* 191, pp. 91–130.
- Wagh, A.S., D. Dingh and S.Y. Jeong (2000). Mercury Stabilization in Chemically Bonded Phosphate Ceramics. Invited paper for Environmental Protection Agency’s Workshop on Mercury Products, Processes, Waste, and the Environment: Eliminating, Reducing and Managing Risks, Baltimore, MD, 22–23 March 2000.
- Watson, A. (2001). Comments on the “Report on the analysis of PCDD/PCDF and Heavy Metals in Soil and Egg samples related to the Byker incinerator”. <http://www.greenpeace.org.uk/media/reports/alan-watson-comments-on-the-byker-ash-report>.
- Werther, J., and M. Sanger (2000). Emissions from sewage sludge combustion in Germany – status and future trends, *Journal of Chemical Engineering of Japan*, Vol. 33 (1), pp. 1–11.
- Wirling, J. Safety aspects in the use of carbonaceous sorbents for entrained-phase adsorption, *Stahl und Eisen* 126 (2006) Nr. 6, pp. 47–54.
- WHO (2014). Safe management of wastes from health-care activities, edited by Y. Chartier et al. – 2nd ed.

## **Annex VII**

### **Cement clinker production facilities**

#### **Summary**

Limestone and other mineral components are burned to form clinker, which is then ground and mixed with certain additives to form the final product, cement. Different types of fuels are used to provide the necessary heat for the production process.

The production of cement clinker results in mercury emissions to air, which originate from the raw materials and fuels. According to the provisions of the Convention, BAT/BEP shall be applied to new constructed or substantially modified facilities to control and, where feasible, reduce mercury emissions. Moreover, parties may use BAT/BEP as one of a range of measures for existing cement clinker production facilities to achieve reasonable progress in reducing emissions over time.

Accordingly, the aim of this chapter is to outline the BAT/BEP options for controlling mercury emissions to air from cement clinker production facilities. It begins by providing an overview of the cement production process and outlines the behaviour of mercury in the process. Primary, secondary and multi-pollutant control strategies for mercury emissions are presented and BAT/BEP options are outlined. In addition, sector-specific information on mercury emissions monitoring is provided. An appendix with additional information on the behaviour of mercury in cement clinker production facilities, together with a summary of emitted mercury chemical forms from various cement plants, is also provided.

## Table of contents

1	Introduction .....	144
2	Processes used, including consideration of input materials and behaviour of mercury in the process .....	145
2.1	Overview of the cement production process .....	145
2.2	Clinker production process .....	145
2.2.1	Description of clinker burning .....	145
2.2.2	Description of rotary cement clinker kilns .....	146
2.3	Input and behaviour of mercury in the process .....	146
2.3.1	Mercury content in different input streams .....	146
2.3.2	Mercury behaviour and mercury balances .....	147
3	Mercury emission control measures .....	149
3.1	Primary measures .....	149
3.1.1	Input control .....	149
3.2	Secondary measures .....	150
3.2.1	Dust shuttling .....	150
3.2.2	Dust shuttling with sorbent injection .....	152
3.2.3	Sorbent injection with polishing baghouse .....	154
3.3	Multi-pollutant control measures .....	155
3.3.1	Wet scrubber .....	155
3.3.2	Selective catalytic reduction .....	157
3.3.3	Activated carbon filter .....	158
4	Best available techniques and best environmental practices .....	159
4.1	Primary measures .....	159
4.2	Secondary measures .....	159
4.3	Multi-pollutant control measures .....	160
5	Monitoring .....	161
5.1	Introduction .....	161
5.2	Sampling points for mercury in the cement process .....	161
5.3	Chemical forms of mercury in the cement process .....	161
5.4	Mercury sampling and measuring methods for the cement process .....	161
5.4.1	Material balance (indirect method) .....	161
5.4.2	Manual methods for mercury spot measurements (Impinger methods) .....	162
5.4.3	Long-term measurements .....	163
5.4.4	Continuous emission monitoring systems for mercury .....	163
6	Appendix .....	164
6.1	Behaviour of mercury in clinker production plants .....	164
6.2	Emitted chemical forms of mercury .....	169
	References .....	170

## 1 Introduction

The production of cement requires considerable material input to burn clinker, which is mixed with certain additives to form the final product: cement (figure 1). Cement has become an indispensable material in the construction of buildings and infrastructure elements (bridges, tunnels, dams, sewers, power plants etc.). For the moment, there is no substitute in sight. For decades, efforts have been made to improve and optimize the cement clinker production process. From an environmental point of view, this relates mainly to the reduction of energy consumption and the minimization of emissions, especially to air. From the economic point of view, the focus is on the substitution of conventional fuels by alternatives, especially the use of waste-derived fuels with sufficient calorific value, also called alternative fuels. To a minor extent, conventional raw materials are also replaced by different types of waste, also called alternative raw materials. In some cases, alternative fuels and alternative raw materials are processed as part of the waste management infrastructure or owing to their availability.

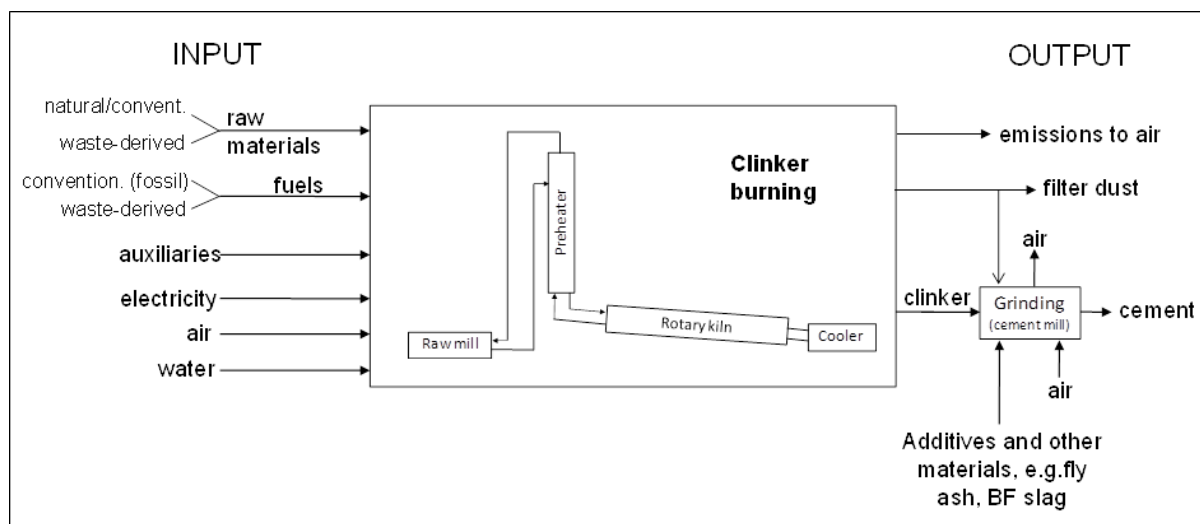

**Figure 1: Principal input and output of cement plants (Schoenberger, 2015)**

The use of alternative fuels or alternative raw materials will not necessarily increase (or decrease) mercury emissions. The level of such emissions simply depends on the relative mercury content of such materials. The use of waste-derived raw materials and fuels for the clinker burning process is called co-processing, whereas the use of waste-derived fuels is sometimes known as co-incineration.



## 2 Processes used, including consideration of input materials and behaviour of mercury in the process

### 2.1 Overview of the cement production process

The production of clinker and cement, respectively, have the following subprocesses in common:

- Raw materials (natural and waste-derived) – quarrying, storage, quality requirements, control and preparation
- Fuels (conventional and waste-derived) – storage, quality requirements, control and preparation
- Kiln systems, kiln firing processes and emission reduction techniques
- Cement grinding – storage, quality requirements, control and preparation
- Packaging and dispatch

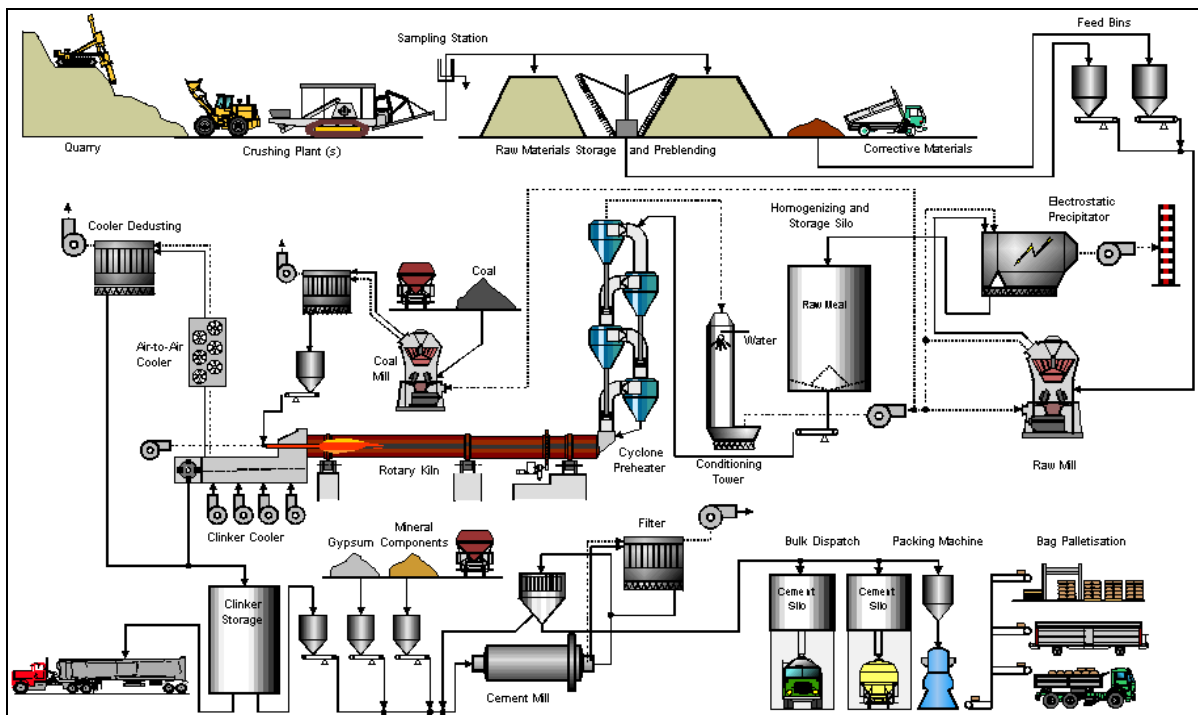

Figure 2: Overview of a cement works (BREF CLM, 2013)

In this document, the focus is on the clinker production process as the dominant source of mercury emissions to air.

### 2.2 Clinker production process

The basic chemistry of the clinker production process begins with the decomposition of calcium carbonate ( $\text{CaCO}_3$ ) present in the raw material at about  $900^\circ\text{C}$ , leaving calcium oxide ( $\text{CaO}$ , lime) and liberating gaseous carbon dioxide ( $\text{CO}_2$ ); this process is known as calcination. This is followed by the clinkerization process, in which the calcium oxide reacts at high temperature (typically between  $1,400^\circ\text{C}$  and  $1,500^\circ\text{C}$ ) with silica, alumina and ferrous oxide to form the silicates, aluminates and ferrites of calcium that constitute Portland clinker (SC BAT Cement, 2008).

Essentially, the clinker production process consists of the clinker burning as such (preheating, kiln firing process with or without precalcination, and with or without a kiln-gas bypass), followed by the clinker cooling. The burnt clinker is fed to the cement mill, where clinker is ground together with additives to produce the final product (namely, cement).

#### 2.2.1 Description of clinker burning

There are four main process routes for the manufacture of cement – wet, semi-wet, semi-dry and dry processes – and the choice of process is, to a large extent, determined by the state of the raw materials (dry or wet), as described below:

1. In the wet process, the raw materials are ground with water to form a pumpable slurry with 28–42 per cent water content. The slurry is directly fed into the kiln. The production capacity of this process is between 100 and 3,600 tons per day (t/d). The wet process requires more energy, and is thus more expensive to operate;
2. In the semi-wet process, the slurry is first dewatered in filter presses. The residual water content varies between 18 and 23 per cent. The filter cake is extruded into pellets and fed to a grate preheater. Kilns of this type, with grate preheaters, were developed by O. Lellep and the company Polysius; as a consequence, they are known as Lepol kilns (Locher, 2000, p 58). The production capacity of this process is between 100 and 3,000 t/d;
3. In the semi-dry process, dry raw meal is pelletized with water and fed into a grate preheater before the kiln. Kilns of this type are also called Lepol kilns. The water content of the feed is further reduced, however, to 11–14 per cent. The production capacity of this process is between 500 and 3,200 t/d. Plants using semi-dry processes are likely to change to dry techniques whenever an expansion or major improvement is required;
4. In the dry process, the raw materials are ground and dried to raw meal in the form of a flowable powder with a water content of less than 1 per cent. The dry raw meal is fed to a cyclone preheater (with four to six stages) or a precalciner kiln, or more rarely, to a long dry kiln. Kilns with preheaters are more energy-efficient and are significantly shorter (40–100 metres). The vast majority of existing kilns are dry process kilns. Their production capacity may vary from 500 to >10,000 t/d.

The majority of kilns are short dry-process rotary kilns. Vertical shaft kilns are not described here as they show low energy efficiency and poor environmental performance.

### 2.2.2 Description of rotary cement clinker kilns

Rotary kilns are refractory-lined steel tubes with a diameter of up to about six meters and a length-to-diameter ratio of between 10:1 and 38:1. They are inclined at a slope of 2.5–4 per cent and rotate at between 0.5 and 5.0 – usually 1.2–3 – revolutions per minute. As a result of the inclination and rotation of the tube, the material to be burned and which is fed into the inlet of the kiln moves down the tube towards the flame burning at the outlet (Locher, 2000, p 55; Ullmann's, 1986; BREF CLM 2013). Thus, the gas stream is flowing counter-currently to the solids. All long wet and long dry kilns are equipped with internals (chains, crosses) to improve heat transfer.

The precalciner technology, as illustrated in figure 3, was developed in the 1960s in order to increase production capacity for a given kiln size. Prior to 1993 in Europe, many of the four-stage, most of the five-stage, and all of the very few six-stage cyclone preheater kilns were equipped with a precalciner and a tertiary air duct (Erhard/Scheuer, 1993). Since then, precalciners are being retrofitted. New plants are always equipped with precalciner technology. The precalciners are positioned between the kiln and the preheater and hot air from the clinker cooler is provided via the tertiary air duct (figure 3). They provide flexibility for the use of different kinds of alternative (waste-derived) fuels, which may have lower calorific value.

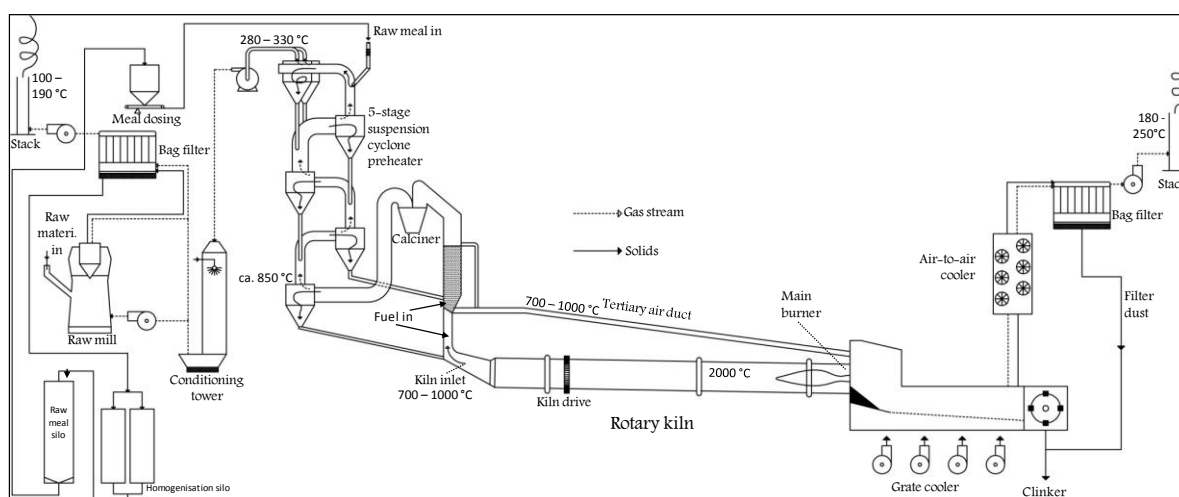

Figure 3: Dry kiln system with a precalciner (Schoenberger, 2015)

## 2.3 Input and behaviour of mercury in the process

### 2.3.1 Mercury content in different input streams

Mercury can be present in all types of input mass streams, in the natural and waste-derived raw materials as well as in the conventional and waste-derived fuels (including hazardous waste fuels). This means that mercury enters the

clinker production systems by all three principal feeding points, i.e., via the raw materials, the main burner and the secondary firing system.

Based on available sources, the mercury content of the input mass streams is compiled in table 1. This compilation confirms that all inputs can contain mercury. It should be noted, however, that mercury contents can be significantly higher or lower than those presented in the table.

	FZKA, 2003			Renzoni et al., 2010		Bref CLM, 2013		Oerter, 2007	CH Buwal, 1999			US PCA, 2006
	Min	Max	Av	Min	Max	Min	Max	50 percentile	Min	Max	Av	Av
<b>Natural or conventional raw materials</b>												
Limestone	0.005	0.1	0.04	<0,005	0.4	<0,01	0.13	0.02				0.017
Marl	0.005	0.1	0.03									0.052
Clay	0.01	0.5	0.2	0.002	0.45	0.02	0.15	0.09				
Sand	0.01	1	0.02	<0,005	0.55			0.03				0.029
Gypsum				<0,005	0.08							
Iron ore		1	0.5	0.001	0.8			0.17				0.078
Raw meal	0.008	1	0.06	0.01	1	0.01	0.5	0.03	0.02	0.6	0.07	
<b>Alternative raw materials</b>												
Spent foundry sand	0.03	4.4	0.3					0.02				
Synthetic Gypsum anhydrite	0.06	1.3	0.1	0.03	1.3							
Blast furnace slag	0.01	1	0.6	<0,005	0.2							0.012
Ash from burning processes, ~ bottom ash from lignite	0.003	1.4	0.3									
Coal fly ash	0.04	2.4	0.3	<0,002	0.8			0.34				0.2
<b>Conventional fuels</b>												
Hard coal	0.01	3	0.3	0.1	13	0.1	3.3	0.4	0.1	3.3	0.42	
Lignite	0.01	0.7	0.2	0.03	0.11			0.09				
Heavy oil				0.006								0.006
Pet coke	0.01	0.09	0.05	0.01	0.71			<0,5				
<b>Alternatives fuels</b>												
Waste tyres	0.1	1	0.4	0.01	0.4			0.17				
Waste oil	0.01	2	0.3					0.1	0.001	0.2		
Waste wood	0.01	1	0.2					0.18	1	0.31	0.37	
Fractions from municipal, commercial and industrial waste	<0,01	1.4	0.3									
Fractions of industrial waste								0.25				
Fractions of municipal waste								0.26				
Meat and bone meal			0.2									
Municipal sludge	0.3	2.5		0.31	1.45				1	5	2.6	
Liquid waste-derived fuel				<0,06	0.22							
Solid waste derived fuel				<0,07	2.77							
Oil shale (also a raw material)	0.05	0.3	0.2	0.05	0.3							0.057

**Table 1: Average values and ranges of the mercury content of natural and alternative raw materials and of conventional and alternative fuels according to different sources, values in ppm**

Legend: Min – minimum; Max – maximum; Av – average

### 2.3.2 Mercury behaviour and mercury balances

Due to the high volatility of elemental mercury and most mercury compounds, the mercury content in the clinker is nil or negligible (Weisweiler/Keller, 1992; Kirchartz, 1994, pp 57 and 63; Locher, 2000, p 156; Eriksen et al., 2007; Renzoni et al., 2010, pp 57, X and XIII). As the raw materials and fuels are burned, mercury is released and an external mercury cycle is formed.

As a consequence of the external cycle, mercury concentrates between the preheater and the dust abatement devices (ESP or bag filter), often simply called the dust filter. A part of the mercury, however, is always emitted with the kiln waste gas. If no filter dust is discarded, nearly all mercury input will finally be emitted with the waste gas (Weisweiler/Keller, 1992; Paone, 2008; Linero, 2011; ECRA, 2013). The logic behind this is that mercury does not end up in the clinker; the only way mercury can leave the system is by being emitted with the waste gas. In order to quantify the enrichment of mercury in the external cycle as well as the percentage of its emission with the waste gas, mercury balances need to be carried out.

It has to be stressed that achieving a mercury balance requires considerable time as it should be carried out at steady-state conditions which could take nearly a month to achieve (Paone, 2008). Accordingly, a balance should be carried out for at least a week, whereby a high frequency of sampling (e.g., hourly averages) is required in order to see the variations. In practice, such a long investigation period is often not maintained.

A mercury balance was published in the form of Sankey diagrams in 2002 (Schäfer/Hoenig, 2002), and this balance has been referenced numerous times (Oerter, 2007; Renzoni et al., 2010; Oerter/Zunzer, 2011; Zheng et al., 2012; Hoenig, 2013; ecra, 2013). The diagrams are given in figure 4 below. It is the result of a so-called “outer mass balance”, in which the raw materials and fuels are the input and the clinker, removed dusts (in the case of a chlorine bypass or when filter dust is removed) and emissions to air from the kiln, raw mill, cooler and chlorine bypass (Sprung, 1988) are the output. The chart on the left shows the mercury balance without and the chart on the right with filter dust removal.

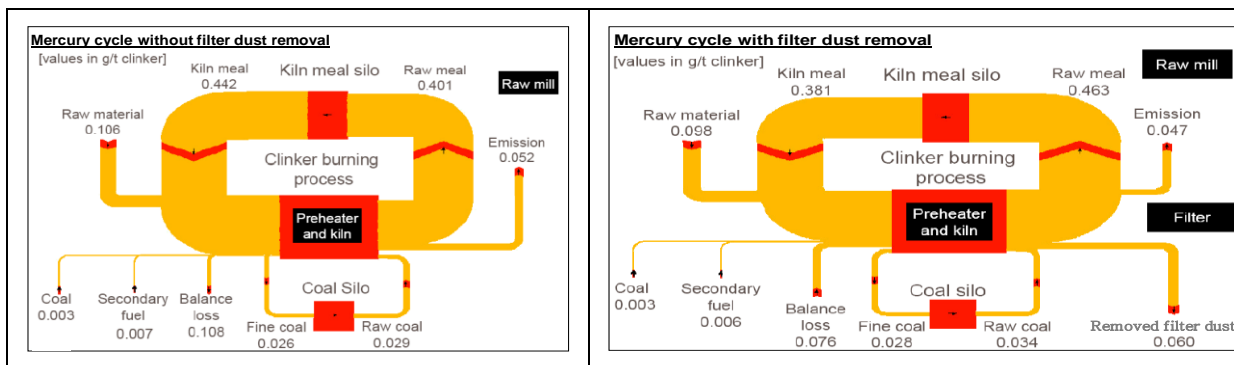

**Figure 4: Sankey diagrams of the mercury balance of a clinker production plant without and with filter dust removal (Schaefer/Hoenig, 2002)**

The mercury balance has been carried out by continuous mercury monitoring at the stack and by taking hundreds of solid samples (Schäfer/Hoenig, 2001). The left chart of Figure 4 indicates that during the balancing period, only half of the mercury input was emitted. Without control, however, all mercury will eventually be emitted via the stack.

The chart on the right shows that the mercury cycle is reduced by removing filter dust from the system.

Figure 4 also indicates that the kiln feed silo is a considerable reservoir for mercury.

In both cases the balance loss represents the mercury stored in the kiln meal silo during the balancing period and the uncertainties of the determination of all (input and output) mass flows and mercury concentrations.

More details on the behaviour of mercury in clinker production plants are included in the appendix.

### 3 Mercury emission control measures

This section describes control measures applicable to both new and existing sources to reduce mercury air emissions from the cement clinker production process. The emissions control measures are additional to, or are used in conjunction with the emissions control measures described in the introductory section of the BAT/BEP guidance document as common emission controls across source categories.

The specific level of mercury control or reduction for a cement clinker production process applying one or more of the measures described here can be determined using the emissions monitoring techniques outlined in section 5 of this chapter and the introductory section of the BAT/BEP guidance document.

#### 3.1 Primary measures

##### 3.1.1 Input control

Mercury enters the kiln system as a trace element naturally present in raw materials and, to a lesser extent, in fuels. A careful selection and control of all substances entering the kiln in order to reduce mercury input along with the use of effective air pollution control devices is very important for reducing mercury emissions from cement clinker production facilities.

Many kilns may be able to reduce emissions by substituting certain components like clay or sand with raw materials that have lower mercury levels than those currently being used. Substituting for the principal raw material, limestone, is more unlikely than for the other additives. Limestone constitutes 75 to 100 per cent of the raw material used to make clinker and, for economic reasons, most plants are located at the limestone source. Purchasing limestone from other locations would not be economically viable owing to transport costs. In addition, limestone quarries are often owned by the cement plant or its parent company and would not be available to other cement plants with different ownership. The characteristics of the limestone, including the mercury content, is especially relevant when choosing the location for a new facility.

Mercury concentrations in raw materials (limestone, marl or clay) vary significantly from quarry to quarry. There are even cases where mercury concentrations vary significantly within a single deposit, thereby sometimes requiring selective mining. In those cases, after exploration and analyses of the quarry, it is, in principle, possible to define specific parts of the quarry with higher mercury concentrations and to use limestone from zones where the concentration is lower. In many cases, however, such a procedure is too complex to manage and cannot always be carried out.

Other non-limestone raw materials (e.g., clay, shale, sand, and iron ore) are typically purchased from various offsite sources and transported to the plant. Plants may have access, therefore, to lower-mercury materials, although the extent to which this is feasible would have to be determined on a site-specific basis. So-called “corrective” materials such as bauxite, iron ore or sand may be required to adjust the chemical composition of the raw mix to the requirements of the process and product specifications.

To a limited extent, alternative raw materials are used to substitute natural raw materials and correctives.

In cases where alternative raw materials lead to a significant increase in the mercury intake into the system they may have to be replaced by another alternative material. Fly ash, for example, can have a higher or lower mercury content than the raw materials that it replaces; therefore the source of fly ash may have to be carefully selected.

The cement production process uses conventional fuels such as coal, gas, petroleum coke and oil, along with alternative fuels such as tyres and other waste-derived fuels. The selection of fuels, including alternative ones, with a low mercury content and the use of a quality assurance system to guarantee the characteristics of the fuels used are therefore very important for reducing mercury emissions from cement clinker production facilities.

In general the cement-plant permits specify which waste-derived raw materials and fuels the plant is allowed to use or burn. The mercury content in alternative raw materials and fuels can also be limited in the permit, which may also include requirements that periodic analyses must be carried out and that, in the event of a switch of raw material or fuel, the limits must be adhered to. For example, the permit issued to Cementa AB, Slite, in Sweden has a limit of less than 2 ppm mercury in some specified waste-derived fuels e.g. plastics, tyres and waste oil (Permit Cementa AB, 2007).

Examples of limit values for mercury content in wastes used in cement plants in some countries are given in table 2.

Type of waste	Austria	Germany	Switzerland
Plastic	2	1.2	
Paper	2	1.2	

Spent oil, solvents	2	1	
Sewage sludge	3		
Combustible waste in general	0.5		0.5
Waste used as raw material			0.5

Table 2: Examples of limit values for mercury content in some wastes used in cement plants, values in mg/kg dry substance [ppm] (BREF CLM, 2013)

### Achieved environmental benefits

Consistent low levels of mercury in input material achieve low mercury emissions. In 2014, 60 per cent of the fuels used at Cementa AB, Slite, in Sweden were alternative fuels. Owing to the low mercury content in the limestone and effective input control, mercury emissions were 0.0014 mg Hg/Nm<sup>3</sup> (average over the sampling period, periodical measurements at reference conditions 273 K, 101.3 kPa, 10 per cent oxygen and dry gas). The plant also has a wet scrubber for SO<sub>2</sub> abatement but the effect of this scrubber on mercury emissions has not been analysed.

### Applicability

Input control can be applied at all cement plants.

### Reference plant

Cementa AB: Slite, Sweden

## 3.2 Secondary measures

### 3.2.1 Dust shuttling

A proven technology to limit the build-up of mercury levels within the kiln dust is the selective shuttling or what is known as “bleeding” of mercury enriched kiln dust.

The mercury enriched kiln dust is extracted from the dust and mercury circulating in the kiln (see figure 4). Following its extraction, the dust is reintroduced directly at the finish mill (after the kiln) with clinker and gypsum.

Dust shuttling can be performed in two configurations:

1. “Raw-mill-off” dust shuttling (kiln is operating alone): this is efficient in the removal of mercury. The collected dust from the preheater has relatively higher mercury concentrations because it is not diluted inside the raw mill.
2. “Raw-mill-on” dust shuttling (kiln and raw mill are operating in line because kiln gases are drying the raw meal inside the raw mill): this is less efficient in the removal of mercury. The collected mercury enriched pre-heater dust is diluted inside the raw mill. It should be noted that this case is subdivided into three configurations:
  - Plants equipped with vertical raw mill => all kiln gases go through raw mill => very little mercury in filter dust => better to apply raw-mill-off dust shuttling only; this also applies to plants with ball mill and high raw material moisture content;
  - Plants equipped with ball raw mill => some kiln gases may bypass the raw mill => could consider to apply some raw-mill-on dust shuttling on the bypass stream if this stream is equipped with a separate dust filter;
  - Plants equipped with a bleed filter separate from the main kiln and raw mill filter. This smaller bleed filter is fed with pre-heater gas. Dust shuttling from this filter is efficient as long as all the remaining gas goes through the raw mill.

The temperature in the dust collector is significant. The vapour pressure of mercury drops significantly with reduced temperature (see figure 6.5 of the appendix). Furthermore, figure 5 shows that the adsorption of mercury on the dust surface increases as the temperature falls. This effect mainly applies to oxidized mercury and less to elemental mercury. To achieve good efficiency of dust-shuttling technology the gas temperature must be below 140 °C and

preferably at or below 120 °C. In a raw-mill-on operation the gas temperature in the filter is usually between 90 and 120 °C. In a raw-mill-off-operation it is usually 140–170 °C and can be up to 200 °C. That means that for an efficient dust shuttling the temperature in a raw-mill-off-operation must be reduced in a conditioning tower or by quenching with air to a temperature range of 120–140 °C. Reducing the temperature below 140 °C by water conditioning often results in corrosion of the system due to sulfuric acid condensation unless the walls of the dust collector and ducting are extremely well insulated. Often the hoppers of the dust collector must be heated. For that reason, appropriate technical measures have to be taken in order to avoid corrosion.

The precipitated dust can be removed from the system independently of the filter type. In some cases where electrostatic precipitators (ESPs) are used, it has been proven to be more effective to remove only the dust from the last section (which is usually the finer part of the dust with a higher specific surface). In other cases this has not been observed. The dust should be collected in a separate silo in order to be able to be flexible regarding its further usage. In many cement plants the dust is used as a mineral addition to the cement, which is in line with most cement standards. If this is not possible, the dust can be used for the production of other products, like certain binders or, if that is also not an option, it has to be treated as waste.

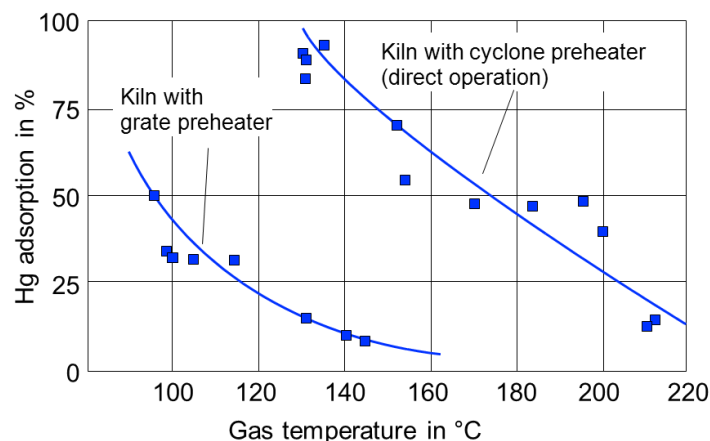

**Figure 5: Comparison of mercury adsorption in grate and cyclone preheaters depending on clean gas temperature (Kirchartz, 1994)**

The efficiency of this technique can be enhanced by adding sorbents with a high surface of specific chemical properties (e.g., activated carbon or calcium-based sorbents) to increase the rate of mercury bound to particles (see section 3.2.2).

#### Achieved environmental benefits

The major environmental benefit is the reduction of mercury emissions. The reduction potential can be significant mainly depending on the waste gas temperature, the percentage of dust shuttled (removed) and the ratio of direct and compound operating mode (see also figure 6.9 in the appendix). The removal efficiency needs to be determined over a time period of at least several days or weeks. Experience shows that with this technique, mercury emissions can be reduced by 10–35 per cent (Oerter/Zunzer, 2012; Schäfer/Hoenig, 2001). Experiences from German cement plants show that using this technique also reduces air emissions of other compounds such as ammonia.

#### Cross-media effects

When the shuttled dust is used as an addition to cement, the mercury will be shifted to the final product. If the dust is distributed evenly in the final product, then the mercury concentration will be similar to that in the original raw materials. The mercury content of the final product should be monitored. Once the cement is hydrated, the mercury will be bound to the matrix. If the shuttled dust cannot be used in the final product, then it will have to be disposed of appropriately.

#### Applicability

The dust shuttling technique can in principle be applied in all cement plants. It is most effective in preheater-preciner kilns during mill off-operation or in a mill off-string, in case only a part of the exhaust gas is used in the raw mill. In other configurations (e. g. at long dry kilns), the technology is less efficient because the exhaust gas is commonly above 200 °C. The achievable efficiency depends on a number of parameters including:

- Relation of oxidized and elemental mercury in the exhaust gas

- Relation of raw-mill-on and raw-mill-off- operations
- Relation of raw mill and kiln capacities
- Achievable exhaust gas temperature in raw-mill-off operations
- Availability of a separate silo for the removed dust
- Possibilities of using the dust
- Level of mercury enrichment in the system (a lower enrichment means that more dust or meal has to be removed from the system)

### Cost

For facilities not already applying dust shuttling, additional investments are required for dust transport systems, storage silo and dosing equipment to the cement mill.

### Reference plants

- Cemex: Brooksville, Florida, United States

#### 3.2.2 Dust shuttling with sorbent injection

Dust shuttling combined with sorbent injection achieves higher mercury removal efficiency than using dust shuttling alone. The sorbents are usually injected during raw-mill-off operation aiming at cutting peak emission in this operation mode, which also reduces the amount of sorbent necessary to control mercury emissions to desired levels. Apart from very few cases (with specific input conditions), the injection of sorbents is not required in raw-mill-on operation, because the mercury capture in the raw mill is sufficient to control mercury emissions to desired levels.

Several sorbent types are available on the market, e.g., carbon, activated carbon, activated lignite (lignite coke), zeolites and reactive mineral mixtures containing active clay or calcium compounds.

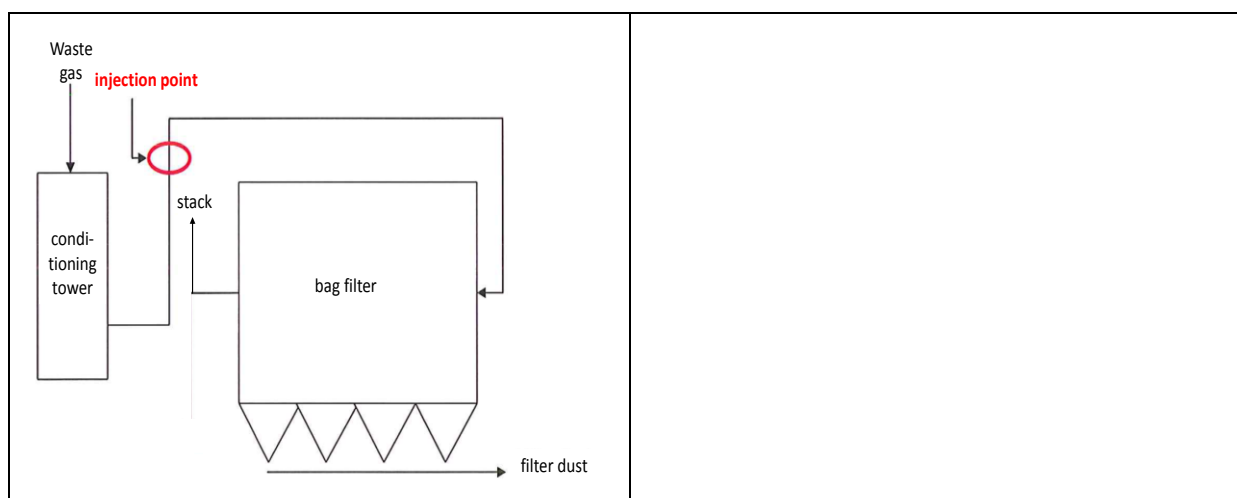
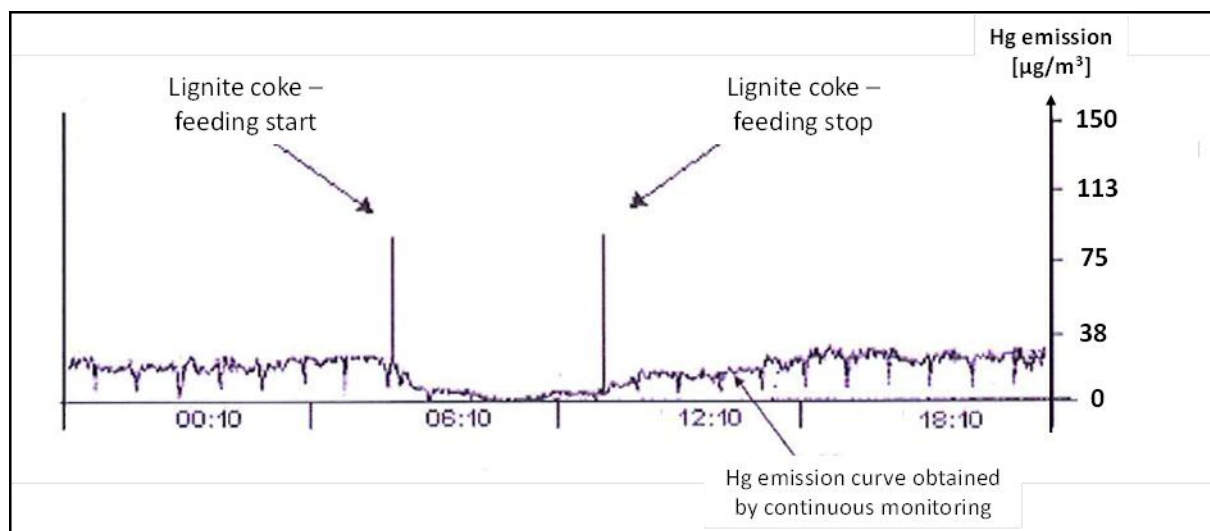

**Figure 6: Illustration of injection of activated lignite (lignite coke) into the flue gas between conditioning tower and bag filter (Lafarge Wössingen, 2015)**

The flue gas temperature should be as low as possible, preferably below 130°C, in order to have high adsorption efficiency. The injection can be carried out via a big bag containing the sorbent and a dosing unit.

After starting the dosage of sorbent, the reduction of mercury emissions can be observed within a couple of minutes (figure 7).





**Figure 7: Example of reduction of mercury emissions by injection of lignite coke; the emission curve shown is gained from continuous mercury monitoring of the waste gas in the stack (based on Lafarge Wössingen, 2015)**

The use of sorbents requires removal of the dust contaminated with the mercury laden sorbent. This is why sorbent injection can be seen as a measure to improve the capture efficiency of dust shuttling. As the dust shuttling technique works better with oxidized mercury than with elemental mercury, the adsorption capacity may be further increased by additives such as bromine, sulfur or more complex compounds with similar chemical properties. In a few cement plants, sorbents impregnated with bromines or sulfur have been used in order to improve the mercury capture efficiency.

When aiming at cutting peak emissions, the dosage period may last only a few hours per day. It is then most likely that the dust with mercury laden sorbent can be added to the cement mill. In case of continuous injection, dust with mercury laden sorbent may have to be disposed of separately as the addition of large amounts of dust with mercury-laden sorbent to the cement can have an adverse impact on the cement quality. If the removed dust is used as cement constituent in the cement mill, possible impacts on cement quality have to be monitored.

#### **Achieved environmental benefits**

Dust shuttling with sorbent injection can achieve very low mercury emission levels. Mercury emissions can be reduced by 70–90 per cent (Lafarge Wössingen, 2015). The emission level depends on which target concentration the system is designed to achieve. In Germany some cement plants have installed sorbent injection systems designed to keep mercury emission levels below  $0.03 \text{ mg/Nm}^3$  as a daily mean value and  $0.05 \text{ mg/Nm}^3$  as a half-hourly mean value at reference conditions 273 K, 101.3 kPa, 10 per cent oxygen and dry gas. At the Lafarge Zement Wössingen plant in Walzbachtal, Germany, the achieved mercury concentration is below  $28 \text{ µg/Nm}^3$  (daily mean value at reference conditions 273 K, 101.3 kPa, 10 per cent oxygen and dry gas).

#### **Cross-media effects**

When the shuttled dust is used as an addition to cement, the sorbent and the mercury will be shifted to the final product. If the dust is distributed evenly in the final product, then the mercury concentration will be similar to that in the original raw materials. In this case the mercury content of the final product should be monitored. There should not, however, be any mercury air emissions from these products. Furthermore, the impact of the sorbent on cement quality should be monitored and controlled. If the shuttled dust cannot be used in the final product then it will have to be disposed of appropriately.

#### **Applicability**

This technique is applicable to new and existing installations. The use of sorbents for mercury air-emission reduction has been reported mainly in the United States and Germany.

Dust shuttling with sorbent injection is more expensive than dust shuttling alone. Because the effectiveness of dust shuttling is very dependent on site specific factors, however, sorbent injection is more widely applicable and can achieve lower overall mercury emission levels.

#### **Cost**

When aiming at cutting peak emissions, where the sorbent is dosed only a few hours a day, the operating costs are low. Only the costs for electricity (fan and dosing unit) and consumption of sorbent (about one ton per day) have to be covered. The estimated operating costs are about €0.2 per ton of clinker (1 ton of activated lignite coke, 168 kWh and

2,300 tons of clinker per day, German prices in 2015). At these levels, it is most likely that the sorbent contained in the filter dust can be added to the cement mill. Consequently, no additional disposal costs have to be incurred.

In case of continuous injection, if the dust with mercury laden sorbent cannot be added to the cement mill it has to be disposed of appropriately.

The investment costs (purchase and installation) for a sorbent injection system are about \$50,000–\$100,000 depending on the supplier and plant capacity.

### Reference plants

- Lafarge Zement Wössingen GmbH., Walzbachtal, Germany (sold to CRH in 2015)
- Cemex OstZement GmbH, Rüdersdorf, Germany
- Holcim Zementwerk Beckum-Kollenbach, Germany (before Cemex)
- Lehigh Cement: Cupertino, California, United States
- Lehigh Cement: Tehachapi, California, United States

### 3.2.3 Sorbent injection with polishing baghouse

In this technique sorbent is injected downstream of the main particulate control combined with a polishing filter to remove the mercury laden sorbent. Depending on the mercury emissions removal requirement, the sorbent can be injected continuously or for cutting peak emissions which typically occur during raw-mill-off-operations.

In order to avoid mixing the mercury laden sorbent with the preheater dust, the sorbent (e.g., activated carbon) is injected into the flue gas after the main dust control and a second dust filter or what is known as a “polishing” baghouse is used to capture the spent carbon. A second dust filter is not common in the cement industry because of the additional capital investment. Figure 8 below illustrates the use of a sorbent injection with a polishing baghouse.

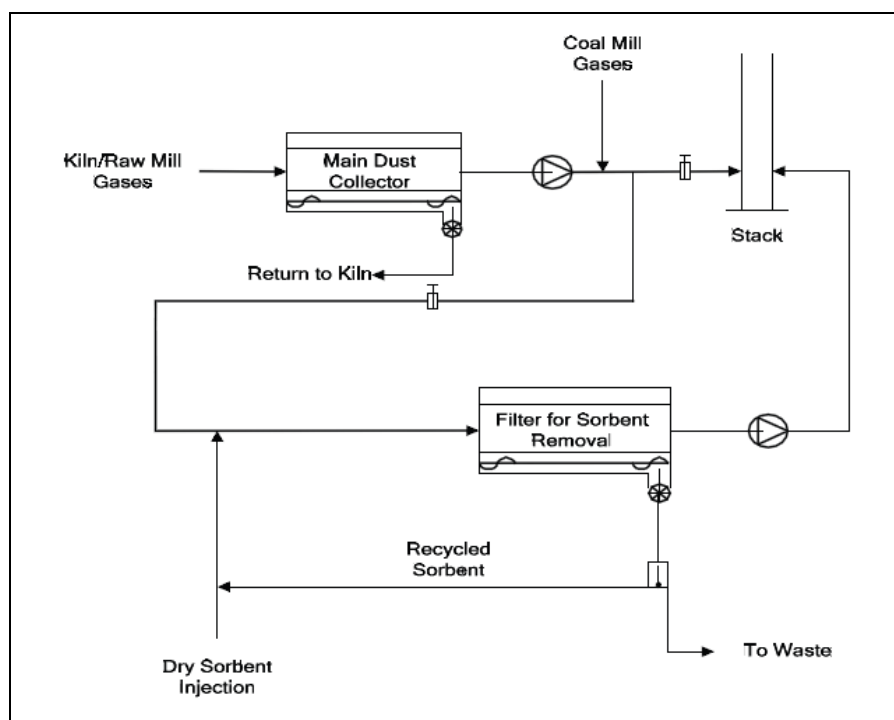

**Figure 8: Injection of activated carbon downstream to the dust filter requiring an additional filter for sorbent removal (Paone, 2009, p 55)**

There are a number of variables that affect the adsorption of mercury on sorbents and, therefore, the efficiency of mercury control. These variables include (Zheng, 2011):

- Mercury speciation and concentration
- Sorbent physical and chemical properties such as particle size distribution, pore structure and distribution, and surface characteristics
- Flue gas temperature
- Flue gas composition

- Sorbent concentration (i.e., injection rate)
- Mercury-sorbent contact time
- Adequacy of sorbent dispersion into the mercury containing gas stream.

Furthermore, filter bag type and filter air-to-cloth ratio also affect the amount of mercury that can be adsorbed, therefore the polishing bag filter must be of an adequate size.

Results from a study to assess key design parameters for a full-scale mercury emission control installation at a cement plant in the United States determined that, in terms of achieving higher mercury control, untreated activated carbon performs comparably to halogen-treated activated carbon, thus avoiding other potential issues associated with use of halogens, for example that of corrosion (US Cement, 2007). In addition, the waste gas temperature should be low in order to achieve high adsorption rates (Renzoni et al, 2010).

#### **Achieved environmental benefits**

The use of activated carbon injection with a polishing baghouse can achieve 90 per cent mercury removal (Barnett, 2013).

#### **Cross-media effects**

The mercury laden dust from this process will have to be disposed of appropriately.

#### **Applicability**

This technique can be applied at all cement kilns. Depending on the required overall mercury emissions removal requirement, the sorbent can be injected continuously, or for cutting peak emissions, which typically occur during raw-mill-off-operations .

In the United States a cement plant has successfully installed and operated an activated carbon injection system, where the activated carbon is injected into the flue gas after the main dust control followed by a polishing baghouse, in order to control mercury emissions. The kiln system at the plant is a preheater and precalciner system, which includes the rotary kiln, a preheater and precalciner tower, and the associated air pollution control system. The plant is equipped with an in-line raw mill, where the gases from the kiln system are routed directly to the raw mill to provide the heat to dry the raw materials. During operating times when the raw mill is off (approximately 15 per cent of the annual operating time frame), the gases bypass the raw mill and are routed directly to the baghouse. The plant typically consumes 1.5 million short tons per year of raw materials and has the capacity to produce 1 million short tons of clinker annually (US Cement, 2007).

#### **Cost**

The United States Environmental Protection Agency (EPA) cost analysis for installing activated carbon injection (ACI) to control mercury at a cement kiln includes a polishing baghouse. These costs were estimated using costs that were originally developed for electric utility boilers. Using exhaust gas flow rates as the common factor, control costs for electric utilities were scaled to derive control costs for Portland cement kilns. Capital and annual cost factors (\$/short ton of clinker) were developed using the boiler costs and gas flow data for the different size boilers. In the United States, the total investment costs for the installation of sorbent injection with a polishing baghouse at a new 1.2 million short ton per year kiln were calculated at \$3.2 million (at 2005 US dollar values). Annualized costs were calculated at \$1.1 million per year (US Cement, 2010 Cost).

In the BREF (BREF CLM, 2013) the investment cost for a dust filter system (bag filter or ESP) is from €2.1 million to €6.0 million for a 3,000 ton/day kiln.

#### **Reference plant**

- Ash Grove Cement: Durkee, Oregon (USA)

### **3.3 Multi-pollutant control measures**

Air pollution control devices installed for removing NO<sub>x</sub> and SO<sub>x</sub> can also achieve co-benefits of mercury capture, and are especially effective on oxidised mercury emissions.

#### **3.3.1 Wet scrubber**

The wet scrubber is a proven technique for flue gas desulfurization in clinker production processes where SO<sub>2</sub> emissions control is necessary.

In a wet scrubber the SO<sub>x</sub> is absorbed by a liquid or slurry which is sprayed in a spray tower. The absorbent is calcium carbonate. Wet scrubbing systems provide the highest removal efficiencies for soluble acid gases of all flue-gas desulfurization (FGD) methods with the lowest excess stoichiometric factors and the lowest solid waste production

rate. Wet scrubbers, however, also significantly reduce HCl, residual dust, NH<sub>3</sub> and, to a lesser extent, metals, including mercury emissions.

The slurry is sprayed countercurrent to the exhaust gas and collected in a recycle tank at the bottom of the scrubber, where the formed sulfite is oxidized with air to sulfate and forms calcium sulfate dihydrate. The dihydrate is separated and, depending upon the physico-chemical properties of gypsum, this material can be used in cement milling and the water is returned to the scrubber.

Gaseous compounds of oxidized mercury are water-soluble and can be absorbed in the aqueous slurry of a wet scrubber system, and, therefore, a fraction of gas-phase oxidized mercury vapours may be efficiently removed. Gaseous elemental mercury is insoluble in water, however, and therefore is not absorbed in such slurries. The speciation between oxidized mercury and elemental mercury can vary significantly between kilns and is also dependent on the process conditions of the kiln operation, all of which will affect the amount of mercury that is removed in a wet scrubber. In wet desulfurization processes, gypsum is produced as a by-product, which is used as a natural gypsum replacement added to the clinker in the finish mill.

### **Achieved environmental benefit**

In the United States, five cement kilns have limestone wet scrubbers installed to control SO<sub>2</sub> emissions and these also co-control mercury air emissions. Based on stack tests and data from those five limestone wet scrubbers, up to 80 per cent of the total mercury air emissions are co-controlled (i.e., removed) (Barnett, 2013). The removal efficiency will be lower at cement plants with high elemental mercury concentrations in the exhaust gas.

### **Applicability**

A wet scrubber is typically used in cement plants with high SO<sub>2</sub> emissions.

For cement plants this technique is most effective where the dominant emissions of mercury are in the oxide form. If there are significant levels of elemental mercury, wet scrubbers are not effective unless additives to oxidize the mercury are used.

### **Cross-media effects**

- Mercury shifted to by-product production such as gypsum

### **Cross-media effects (other than mercury-related)**

- Increased energy consumption
- Increased waste production from flue-gas desulfurization (FGD), and when maintenance is carried out, production of additional waste
- Increased CO<sub>2</sub> emissions
- Increased water consumption
- Potential emissions to water and increased risk of water contamination
- Increased operational cost
- Replacement of natural gypsum

### **Cost**

In 2000, the investment costs for the scrubber at Castle Cement (including plant modifications) were reported to be €7 million and the operating costs were about €0.9 per ton of clinker. In 1998 Cementa AB in Sweden incurred investment costs of about €10 million and operating costs of about €0.5 per ton of clinker. With an initial SO<sub>2</sub> concentration of up to 3,000 mg/Nm<sup>3</sup> and a kiln capacity of 3,000 tons of clinker per day, the investment costs in the late 1990s were €6 million–€10 million and the operating costs €0.5–€1 per ton of clinker. For a reference cement plant with a capacity of 1,100 tons per day, a wet scrubber operated to 75 per cent SO<sub>x</sub> reduction was calculated to incur investment costs of €5.5 million, variable operating costs of €0.6 per ton of clinker and total costs of €3 per ton of clinker (2000 data, 10 years lifetime, 4 per cent interest rate, includes electricity, labour and lime costs). In 2008, the European cement industry reported investment costs of between €6 million and €30 million and operational costs of between €1 and €2 per ton of clinker (BREF CLM 2013).

In the United States, the total capital costs to install a wet scrubber at a new 1.2 million short ton per year kiln, including the cost of a continuous emissions monitoring system (CEMS), were calculated at \$25.1 million per kiln (at 2005 US dollar values). Annualized costs, including monitoring, were calculated at \$3.6 million per year per kiln (US Cement, 2010 Cost).

Reference plants

- Cementa AB: Slite, Sweden
- Holcim: Midlothian, Texas, United States
- Lehigh Cement: Mason City, Iowa, United States

### 3.3.2 Selective catalytic reduction

Selective catalytic reduction (SCR) reduces NO<sub>x</sub> emissions by injecting NH<sub>3</sub> or urea into the gas stream which reacts on the surface of a catalyst at a temperature of about 300–400 °C. The SCR technique is widely used for NO<sub>x</sub> abatement in other industries (coal fired power stations, waste incinerators) and has been applied in the cement industry since the 1990s (CEMBUREAU, 1997; Netherlands, 1997) in six cement plants worldwide (Germany, Italy and the United States). The SCR catalyst consists of a ceramic body which is doped with catalytically reactive compounds like V<sub>2</sub>O<sub>5</sub> or the oxides of other metals. The main purpose of the SCR technique is to catalytically reduce NO and NO<sub>2</sub> in exhaust gases to nitrogen.

In the cement industry, basically two systems are considered: low dust configuration between a dedusting unit and stack, and a high dust configuration between a preheater and a dedusting unit. Low dust exhaust gas systems require the reheating of the exhaust gases after dedusting, which may cause additional energy costs and pressure losses. High dust systems do not require reheating, because the waste gas temperature at the outlet of the preheater system is usually in the right temperature range for SCR operation. On the other hand, the high dust load before filter does not pose a problem for low dust systems; these systems, therefore, allow much longer operation time of the catalyst. Furthermore, they are installed at lower temperature (smaller volume flow) allowing smaller number of catalyst layers.

From experience in the power sector it is well known that – as a side effect – on the surface of SCR catalysts, elemental mercury is oxidized to a certain extent. This oxidized mercury is more likely to be removed in downstream air pollution control devices, such as a dust filter. This means that with the SCR technique, elemental mercury will be transformed into chemical forms which are easier to capture.

Currently extensive research is carried out to improve the applicability of SCR technology for NO<sub>x</sub> abatement in the cement industry. Investigations at European cement plants (Germany, Austria, Italy) indicate that the oxidizing effect on elemental mercury is observed if the SCR technique is applied in the exhaust gas of cement plants. Mercury removal can only be achieved if a capture system is located after the SCR catalyst. That means that it works in combination with high-dust SCR, but not with tail-end (low dust) SCR.

#### Achieved environmental benefits

As an indirect environmental benefit, elemental mercury is partly transformed into oxidized mercury. As a side effect it can improve Hg capture in combination with dust shuttling and a wet scrubber.

#### Cross-media effects (other than mercury-related)

The power demand of the cement plant increases by 5–6 kWh per ton of clinker, lowering the energy efficiency of the process and increasing indirect greenhouse gas emissions. Furthermore, additional waste is produced containing rare metals.

#### Operational experience

Currently four SCR installations are in operation at cement plants in Europe and a few more are in operation (or demonstration) around the world. Quantification of the mercury oxidizing effect requires further investigation.

#### Applicability

The mercury oxidizing side effect can be achieved only in cement plants which are equipped with a high-dust SCR system because it is installed upstream of a dust collection system. The increase in Hg reduction can be achieved in combination with dust shuttling or with a wet scrubber.

#### Cost

The results from the use of the SCR technique have shown a cost level of €1.25–€2.00 per tonne of clinker, depending on the plant size and the NO<sub>x</sub> removal efficiency required. The economics of the SCR technique are dominated by the investment costs. The use of catalysts increases the operational costs due to higher energy consumption due to pressure drop and cleaning air for the catalyst. Specific operating costs of SCR have declined to around €1.75–€2.0 per tonne of clinker. (BREF CLM, 2013)

#### Reference plants

- High-dust SCR: Schwenk Zement KG: Mergelstetten. Germany
- LaFarge: Joppa, Illinois, United States

### 3.3.3 Activated carbon filter

Pollutants such as SO<sub>2</sub>, organic compounds, metals (including volatile metals such as mercury and thallium), NH<sub>3</sub>, NH<sub>4</sub> compounds, HCl, HF and residual dust (after an ESP or fabric filter) may be removed from the exhaust gases by adsorption on activated carbon. The activated carbon filter is constructed as a packed bed with modular partition walls. The modular design allows the filter sizes to be adapted for different gas throughputs and kiln capacity (BREF CLM, 2013).

In principle, the adsorber consists of several vertical filter beds packed with lignite coke. Each filter bed is subdivided into a thin (0.3 m) and a thick (1.2 m) bed. The waste gas from the bag filter is pressed through the lignite coke adsorber by the fan. The bed height is about 20 m. In the first thin bed, the waste gas is pre-cleaned while in the second thick bed, the pollutants are further removed from the waste gas. The saturated lignite coke is recycled externally and is replaced by fresh or recycled coke. This exchange takes place semi-continuously in small steps (every three hours). Fresh coke is only charged to the thick beds through distribution troughs and moves down the filter bed (about 0.3 m/d). In the thin beds, the coke moves down to about 1.2 m/d and, for that reason, is called a moving bed adsorber. At the bottom of the thick filter beds, the lignite coke is withdrawn, and, by means of elevator conveyors, recycled back to the thin beds. Consequently, a countercurrent operation mode is achieved. In 2007, the former ESP was replaced by a well-designed bag filter to achieve low dust contents prior to the adsorber.

#### Achieved environmental benefits

The most important characteristic of the activated carbon filter is the effective simultaneous removal of a broad spectrum of pollutants. As a result the removal efficiency is very high. Only some very volatile short chain hydrocarbons (C1–C4 molecules) are not efficiently captured and benzene is not totally removed. All other organic pollutants, however, including persistent organic pollutants (POPs) and also volatile heavy metals, especially mercury and thallium, are adsorbed with an efficiency of more than 90 per cent. In addition, sulfur dioxide is reduced by more than 90 per cent (Schoenberger, 2009).

#### Cross-media effects

Waste, such as used activated carbon with mercury and other pollutants such as polychlorinated dibenzo(p)dioxins and furans (PCDD/F) have to be disposed of appropriately.

#### Cross-media effects (other than mercury related)

Increased electricity consumption due to pressure drop of the adsorber is the most important cross-media effect.

#### Applicability

The only activated carbon filter existing in the cement industry is installed at a cement works in Siggenthal, Switzerland. The Siggenthal kiln is a four-stage cyclone preheater kiln with a capacity of 2000 ton of clinker per day. Measurements show high removal efficiencies for SO<sub>2</sub>, metals and PCDD/F. During a 100-day trial, the SO<sub>2</sub> concentrations at the filter inlet varied between 50 and 600 mg/Nm<sup>3</sup>, whereas the outlet concentrations were always significantly below 50 mg/Nm<sup>3</sup>. Dust concentrations dropped from 30 mg/Nm<sup>3</sup> to significantly below 10 mg/Nm<sup>3</sup> (BREF CLM, 2013). An activated carbon filter can be fitted to all dry kiln systems. Monitoring and control of temperature and CO are especially important for such processes in order to prevent fires in the coke filter (BREF CLM, 2013).

#### Cost

The system at Siggenthal also includes a selective non-catalytic reduction (SNCR) process and in 1999, the city of Zurich financed about 30 per cent of the total investment cost of approximately €15 million. The investment in this abatement system was made to enable the cement works to use digested sewage sludge as fuel. Operating costs may increase (BREF CLM, 2013).

#### Reference plants

The only reference plant in the cement sector is the activated carbon filter (lignite coke moving bed adsorber) at the cement works of Holcim in Siggenthal, Switzerland. Lignite coke moving bed adsorbers have also been applied, however, in other sectors, especially in the waste incineration sector.

## 4 Best available techniques and best environmental practices

Mercury emissions can be reduced by primary measures such as controlling the amount of mercury in the inputs to the kiln and secondary measures such as dust shuttling and sorbent injection. Mercury can also be controlled as a co-benefit of applying multi-pollutant control techniques such as wet scrubbers, selective catalytic reduction and activated carbon filters.

Reported mercury emissions show that the majority of cement plants worldwide have mercury emissions below 0.03 mg/Nm<sup>3</sup>. In their report on mercury in the cement industry (Renzoni et al., 2010), it was found that many values are under 0.001 mg mercury/Nm<sup>3</sup> (under the detection limit) and very few values are higher than 0.05 mg mercury/Nm<sup>3</sup>.

The indicative performance level associated with best available techniques and best environmental practices (BAT/BEP) in new and existing cement clinker production facilities for control of mercury emissions to the air is below 0.03 mg Hg/Nm<sup>3</sup> as a daily average, or average over the sampling period, at reference conditions 273 K, 101.3 kPa, 10 per cent oxygen and dry gas.

This indicative performance level is generally achievable using techniques included in this guidance document. Specific factors, however, that may not allow a plant to achieve this emission level, are, for example:

- High mercury content of the local limestone deposit;
- Plant design and operating mode and conditions;
- Sampling times when monitoring mercury air emissions.

### 4.1 Primary measures

Careful selection and control of raw materials and fuels entering the kiln offer an effective way to reduce and limit mercury emissions. To reduce mercury input to the kiln the following measures can be taken:

- Use of limit requirements on mercury content in raw materials and fuels;
- Use of a quality assurance system for input materials, especially for waste-derived raw materials and fuels, for the control of mercury content in input materials;
- Use of input materials with low mercury content when possible, and avoiding the use of waste with high mercury content.
- Selective mining if mercury concentrations vary in the quarry, when possible;
- Choice of location for new facilities that takes mercury content in the limestone quarry into account.

### 4.2 Secondary measures

There are a number of secondary measures that should be considered, as appropriate.

The emissions of mercury to air can be reduced by dust shuttling and collecting the dust instead of returning it to the raw feed. One way of further improving the effectiveness of dust shuttling is to lower the off-gas temperature after the conditioning tower to below 140 °C to improve the precipitation of mercury and its compounds during dust filtration. The collected dust can be used in the cement finish mill or used for the production of other products. If this is not possible it has to be treated as waste and disposed of appropriately.

Dust shuttling combined with sorbent injection achieves higher mercury removal efficiency than dust shuttling alone. The sorbents are usually injected during raw-mill-off operation aiming at cutting peak emission in this operation mode. Dust shuttling with sorbent injection can achieve very low mercury emission levels; the mercury emissions can be reduced by 70–90 per cent. The emission level depends on which target concentration the system is designed to achieve.

When using sorbent injection with a polishing bagfilter the sorbent is injected into the flue gas after the main dust control and using a second dust filter or polishing bag house to capture the spent sorbent. Depending on the required overall mercury emissions removal requirement the sorbent can be injected continuously, or for cutting peak emissions, which typically occur during raw-mill-off-operation. The use of activated carbon injection with a polishing baghouse can achieve control efficiencies of 90 per cent mercury removal. Using these technologies, it has to be considered that the valorization of the shuttled dust in cement production may be limited and additional waste may be produced.

Additives, such as bromine, which further oxidize the mercury can also increase the mercury removal efficiency of sorbent injection.

### 4.3 Multi-pollutant control measures

Air pollution control devices installed for removing sulfur oxides and nitrogen oxides can also achieve co-benefits of mercury capture.

The wet scrubber is an established technique for flue gas desulfurization in the cement manufacturing process. Gaseous compounds of oxidized mercury are water-soluble and can be absorbed in the aqueous slurry of a wet scrubber system, and, therefore, a major fraction of gas-phase oxidized mercury vapours may be efficiently removed. Gaseous elemental mercury is insoluble in water, however, and therefore is not absorbed in such slurries unless additives to oxidize the mercury are used.

The SCR technique reduces NO and NO<sub>2</sub> catalytically in exhaust gases to N<sub>2</sub> and, as a side effect, elemental mercury is oxidized to a certain extent. This oxidized mercury can be better removed from the gas stream in a subsequent dust filter or wet scrubber. This side effect can be used with the high dust SCR technique, but not with low dust (tail end) SCR.

Pollutants such as SO<sub>2</sub>, organic compounds, metals (including volatile ones as mercury and thallium), NH<sub>3</sub>, NH<sub>4</sub> compounds, HCl, HF and residual dust (after an ESP or fabric filter) may be removed from the exhaust gases by adsorption on activated carbon. The activated carbon filter is constructed as a packed-bed with modular partition walls. The modular design allows the filter sizes to be adapted for different gas throughputs and kiln capacity.

Using these techniques, cross-media effects should be considered, such as shifting mercury streams to products like gypsum from a wet scrubber, or producing additional wastes such as spent activated carbon which requires appropriate disposal.



## 5 Monitoring

### 5.1 Introduction

General and cross-cutting aspects of testing, monitoring and reporting are discussed in the monitoring chapter of the BAT/BEP guidance. Specific aspects inherent to cement production processes will be discussed in this section.

The objective of an emissions reporting scheme has an important impact on the type of monitoring chosen for a certain installation. Accordingly, testing and monitoring comprise the material balance method (based on input sampling and analyses) and emission measurements (output) at the stack.

Emission limits for mercury in the cement process may be set as an average for a certain time period (e.g., 8 hours, 12 hours, 24 hours, 30 days) or may be specified for shorter period of time (e.g., 30 minutes) to prevent high peak levels. Emission limits may also be set in terms of the amount of mercury per amount of clinker produced (e.g., mg/t of clinker produced), such as in the United States, and in terms of concentration ( $X \mu\text{g}/\text{Nm}^3$  at  $Y$  per cent of  $\text{O}_2$ , dry basis) in the stack as is the case in Europe. In some cases there are also limits on the amount of mercury in raw materials and fuels, mainly where alternatives are used. Testing and monitoring of mercury air emissions in the cement process need to take into consideration all the conditions set for the specific case being tested or monitored at a facility.

### 5.2 Sampling points for mercury in the cement process

According to the mercury input and output of the cement clinker production process discussed previously in this document, main sampling points for mercury in the cement process would be:

- For the material balance approach: the untreated raw materials and fuels, dust collected and removed from the system
- For emission measurement; emission from stacks

Emission measurements are important for comparison with emission limit values, if they have been set. Figure 1 of chapter 1 illustrates a scheme of the main inputs and outputs of a cement plant system, which are potential points for mercury monitoring.

### 5.3 Chemical forms of mercury in the cement process

Regarding the material balance method, the chemical binding of mercury in the solid materials is of low importance, as the risk of losing a part of the mercury during sampling and analysis is low. Care has to be taken, however, during storage and treatment of samples containing mercury, as some of them may be lost due to adsorption to containments or heating of the sample during treatment (e.g., grinding).

Regarding stack measurements, mercury may be present in the form of elemental mercury or in the oxidized form ((Hg(I) or Hg(II)), in vapour form (see the appendix). It may also exist in particle-bound adsorbed form. Sampling and analysis must comprise total mercury. As analysis and detection are for elemental mercury, oxidized Hg must be converted to elemental mercury. Mercury oxidized compounds produced in the cement kiln are assumed to be, for example,  $\text{HgCl}_2$ ,  $\text{HgO}$ ,  $\text{HgBr}_2$ ,  $\text{HgI}_2$ ,  $\text{HgS}$  and  $\text{HgSO}_4$ . While discrete sampling methods (spot samples) can handle both vapour and solid phases, continuous emission systems measure only the vapour phase since a particulate filter is used to protect the instrument. It can be accurate enough to measure gaseous mercury if efficient dust abatement is applied since the particle-bound mercury is very low at low dust concentrations.

### 5.4 Mercury sampling and measuring methods for the cement process

Methods for sampling and measuring mercury in the cement process include, for material balance, solid sampling and analyses of untreated raw materials and fuels, removed filter dust; and for emission measurements, spot sampling, semi-continuous method and continuous method at the stack, process control, and gas temperature in the dust filter.

#### 5.4.1 Material balance (indirect method)

The major pathways by which mercury leaves the cement kiln system are stack emissions and cement kiln dust, if it is removed from the kiln system.

System mercury mass balance may offer a better estimate of emissions than spot stack measurements. Variability of mercury levels in fuels and in input materials and representativeness of samples will influence the results of a spot sample.

In the material balance method, the sampling of raw material, fuels, and collected dust must lead to a representative sample. If wastes are co-incinerated, the variability of the composition could be greater and additional care must be taken in order to get a representative sample.

The American Society for Testing and Materials (ASTM) and European standards for sampling, and for initial preparation of solid sample for analysis, which were developed for coal sampling (standards ASTM D2234<sup>45</sup> and D2013<sup>46</sup>, and standard EN 932-1<sup>47</sup>), may be used in the sampling of inputs to the cement process.

Sampling should be performed periodically and may comprise a composite sample at the end of a certain period. For example, samples of raw material, fuel and dust collected may be taken daily or weekly, depending on the mercury content variation. If weekly samples are taken of raw material components and fuels, the monthly composite samples will be made from the weekly samples. Each monthly composite sample should be analysed to determine mercury concentrations representative for the specific month.

The analytical methods used to determine mercury concentration may be EPA or ASTM methods such as EPA 1631<sup>48</sup> or 7471b<sup>49</sup>. Chemical analysis is performed by cold vapour atomic absorption spectroscopy (CVAAS) or by cold vapour atomic fluorescence spectroscopy (CVAFS) or by inductively coupled plasma mass spectrometry (ICP-MS).

The monthly input rate (input mass of mercury per month) is both the product of the mercury concentration of the monthly samples and the respective mass of raw material components feed and fuels introduced in the process. The consecutive 12 month mercury input rate (input mass of mercury per year) is the sum of the 12 individual monthly records.

**Advantages**<sup>50</sup>: low annual cost relative to continuous and semi-continuous methods (assuming monthly sampling and one week composite sample per month); medium accuracy representativeness for long term emission averages; medium precision; results are given mainly in total mercury;

**Disadvantages**: low accuracy at low emission levels; method may not be usable to demonstrate compliance with emissions limits depending on how emission limits are set.

#### 5.4.2 Manual methods for mercury spot measurements (Impinger methods)

Manual methods of stack sampling and analysis in the cement process play an important role in the checking of compliance in the developing world, and they are frequently used for that purpose. In a few developed countries (Germany, the United States) regulations are changing requirements from spot stack sampling to continuous sampling and analysis (analyser or sorbent trap CEMS) in order to provide for a better characterization of emissions. Measurement of mercury emission by manual methods can be part of an annual campaign for measuring emissions of other pollutants in the cement process.

Standards for spot measurement of mercury are mainly from Europe and the United States. Japan also has its own standards. These may differ in terms of the form of mercury measured. Usual test methods for sampling and measuring mercury in stack emissions in Europe (EN methods) and in the United States (US EPA and ASTM methods), which can be used for cement plants are presented and briefly described in the chapter on monitoring of the BAT/BEP guidance document.

For kilns with in-line raw mills, a key issue associated with any type of stack sampling is that mercury emissions typically vary significantly depending on the mode of raw mill operation. Testing during both raw-mill-on and raw-mill-off operating modes is necessary to quantify long term emissions.

**Advantages**: lowest annual cost relative to mass balance, continuous and semi-continuous methods; usually mercury is determined as part of a big measuring campaign for several pollutants, reducing the costs; spot measurement have been used all over the world; accuracy and precision at low levels of emission is from medium to high; mercury speciation is possible.

**Disadvantages**: as the results are only for a short time, it does not give a clear picture of emissions with time; low accuracy for long-term average representativeness; method may not be usable to demonstrate compliance with emission limits depending on how emission limits are set.

<sup>45</sup> ASTM Method D2234: Standard Practice for Collection of a Gross Sample of Coal.

<sup>46</sup> ASTM Method D2013: Standard Method of Preparing Coal Samples for Analysis.

<sup>47</sup> European Standard EN 932-1: Tests for general properties of aggregates. Methods for sampling.

<sup>48</sup> US.EPA Method 1631: Mercury in Water by Oxidation, Purge and Trap, and Cold Vapor Atomic Fluorescence Spectrometry. Revision E, August 2012.

<sup>49</sup> US.EPA Method 7471b: Mercury in solid or semisolid waste (manual cold-vapor technique). Revision 2. February 2007.

<sup>50</sup> Advantages and disadvantages for all methods, for coal-fired power plants, are mainly based on: E. Mazzi, Glesmann, S., Bell, A (2006). Canada Wide Standards Mercury Measurements methodologies for coal-fired power plants. EPRI-EPA-DOE-AW&MA Power Plant Air Pollutant Control "MEGA" Symposium, 28-31 August 2006, Baltimore, Maryland, United States.

<http://www.ires.ubc.ca/files/2010/05/MazziMegapaper152006final.pdf>.

### 5.4.3 Long-term measurements

#### 5.4.3.1 Sorbent trap monitoring systems

The semi-continuous method uses sorbent material to trap Hg emission for further analysis by CVAFS. It can give an accurate characterization of emissions from a cement process and may not be as expensive as, and is easier to operate and to maintain than, CEMS. The reference methods are described in the chapter on monitoring of the BAT/BEP guidance document.

In the United States, sorbent trap-based monitoring systems are approved for mercury emissions monitoring in cement plants. Sorbent trap systems are not approved as a mercury emission monitoring system in the European Union, in consequence of the definition of the emission limit as daily average and partially at national level limits with an even shorter time. As is the case in the United States, the emission limit value is defined as a (rolling) 30-day average and the measurement with such a system is acceptable and widely used.

**Advantages:** medium annual cost compared to other methods listed; high accuracy for low mercury levels; medium-to-high representativeness of long-term average emission; high precision.

**Disadvantages:** possible plugging of sorbent traps due to eventual high emissions of mercury, e.g., when the mill is off; the method may not be usable to demonstrate compliance with emission limits depending on how the emission limits are set; the method does not provide continuous mercury data that can be used to operate mercury controls in the most efficient manner.

#### 5.4.4 Continuous emission monitoring systems for mercury

Continuous emission monitoring is an important tool in gaining better knowledge about time and operation-related variations of mercury emissions from stationary sources and in controlling the operation of mercury-abatement devices. In Europe, continuous emission monitoring systems for mercury (mercury CEMS) are required in some countries, such as Austria and Germany, for cement plants using alternative fuels.

In Germany, cement kilns using alternative fuels have had to be equipped with mercury CEMS since 2000. The first generation of mercury CEMS was developed in the 1990s and underwent suitability tests between 1994 and 2001. Experience has shown that, despite the successful completion of the suitability testing, difficulties arose in practice with regard to the stable long-term operation of CEMS. Instruments were modified and improved over time, as part of the experience gained with their use.

In 2013, the United States approved a final rule setting national emission standards for hazardous air pollutants for the Portland cement manufacturing industry, which includes mercury-specific limits. According to this rule, cement plants subject to limitations on mercury emissions will be required to comply with the mercury standards by operating a mercury CEMS or a sorbent trap-based monitoring system.

**Advantages:** medium-to-high accuracy at low levels; high representativeness of long-term averages; medium-to-high precision; provides continuous data that can be used to operate mercury controls in the most efficient manner.

**Disadvantages:** higher annual cost compared to other methods; periodic quality assurance procedures, calibration and maintenance need experienced personnel; requires calibration for both raw-mill-on- and raw-mill-off-operations because mercury levels typically go beyond the calibrated mill on span during the mill off- operation.

## 6 Appendix

### 6.1 Behaviour of mercury in clinker production plants

As temperature is the most important parameter for the behaviour of mercury and its compounds in the clinker production system, the different mercury species and the reaction conditions will be explained following the temperature profile (see figure 6.1), starting at the hot end with the main burner of the rotary kiln and ending up with the dust filter and stack emissions.

In addition, figure 6.1 contains the temperature profile and provides a non-exhaustive overview of the possible reaction partners and the respective reaction products. It also points out that, in principle, there are three classes of mercury species: elemental mercury ( $\text{Hg}^0$ ), mercurous ( $\text{Hg}^+$ ) and mercuric ( $\text{Hg}^{2+}$ ) forms.

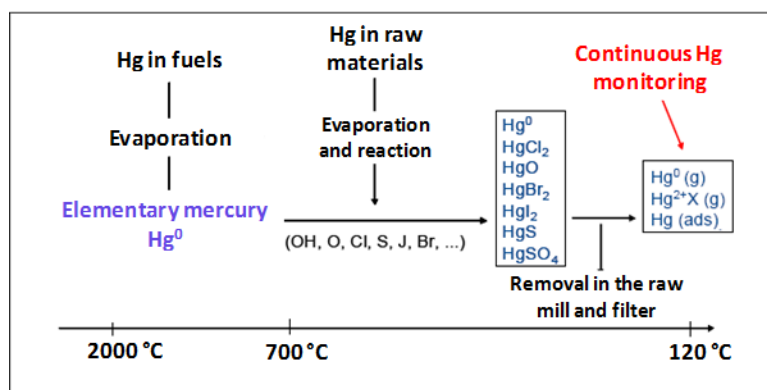

**Figure 6.1: Possible conversion reactions of mercury in the clinker production process (Renzoni et al., 2010; Oerter/Zunzer, 2011; ECRA, 2013)**

Three possible mercury input points (main burner, secondary firing and precalciner, raw meal) are important and will be discussed accordingly.

#### Main burner and rotary kiln

Thermodynamic equilibrium calculations indicate that above 700 °C–800 °C, only elemental mercury is present in the gas phase (Martel, 2000; Schreiber et al., 2005; Krabbe, 2010). This is important for the main burner and the rotary kiln with gas temperatures up to 2,000 °C (see figure 3). Thus, all mercury compounds entering the system via the main burner will be transformed into elemental mercury and will leave the kiln to enter the preheater. As already indicated previously, practically no mercury is incorporated into the clinker.

#### Preheater

In the preheater, there are complex reaction conditions and a temperature profile of the gas phase of about 900 °C–1,000 °C in the kiln inlet and 270 °C–450 °C after the preheater. In case of the existence of a chlorine bypass in a plant, a part of the elemental mercury may be extracted and will be partly adsorbed to the filter dust and partly emitted to air. The elemental mercury from the kiln may be partly transformed to other species in the preheater.

The mercury input via the main burner is described previously. The next input point is the secondary firing which could be the feeding of fuels (conventional or waste-derived) to the kiln inlet or to a precalciner (see figure 3). At temperatures above 700 °C–800 °C, mercury present in the fuel will be converted to elemental mercury, which, as described above, can be transformed to other mercury species in the preheater.

In clinker production plants, the main mercury species tend to be elemental mercury, mercury dichloride ( $\text{HgCl}_2$ ) and mercury oxide ( $\text{HgO}$ ); other mercury species are of less importance (ECRA 2013). All these three species have a high volatility. Mercury oxide decomposes at temperatures above 400 °C.

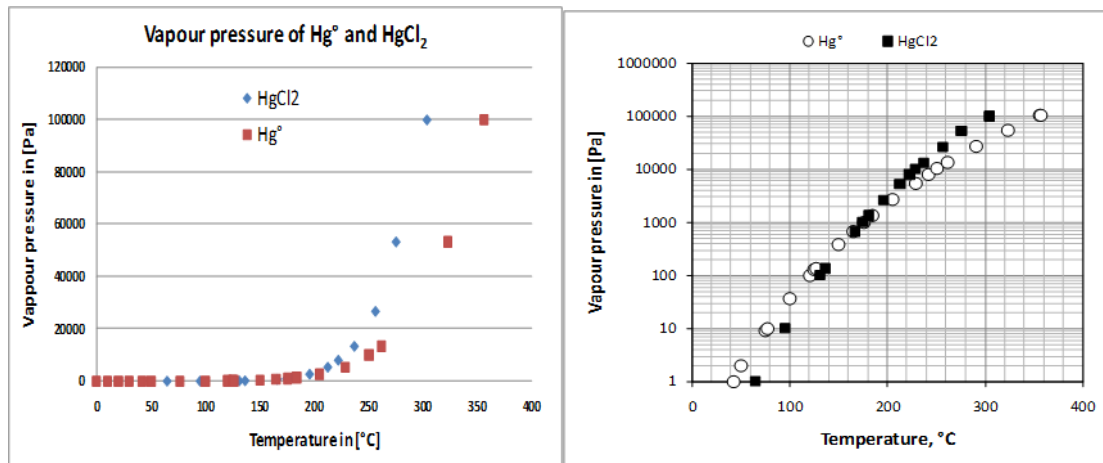

**Figure 6.2: Dependence of the vapour pressure of Hg° and HgCl<sub>2</sub> on the temperature (left chart with linear scale and right chart with logarithmic scale) (Holleman-Wiberg, 1985; CRC Handbook, 1976; CRC Handbook, 1995; CRC Handbook, 2012)**

The vapour pressure of elemental mercury and mercury chloride exponentially increases with temperature. This is illustrated in figure 6.2, which shows the concerned curves on linear and logarithmic scales.

The numbers illustrate the high volatility of these mercury species. Consequently, they are volatilized in the preheater and remain in the gas phase. These physico-chemical properties are confirmed by volatilization tests of the raw meal which represents the third input. These tests indicate that the raw meal contains different mercury species which are volatilized between 180 °C and 500 °C. The left chart in figure 6.3 shows the mercury volatilization curves of four different raw meals.

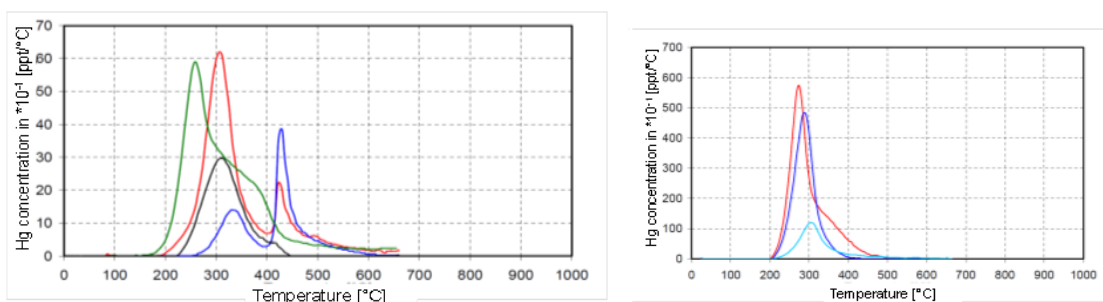
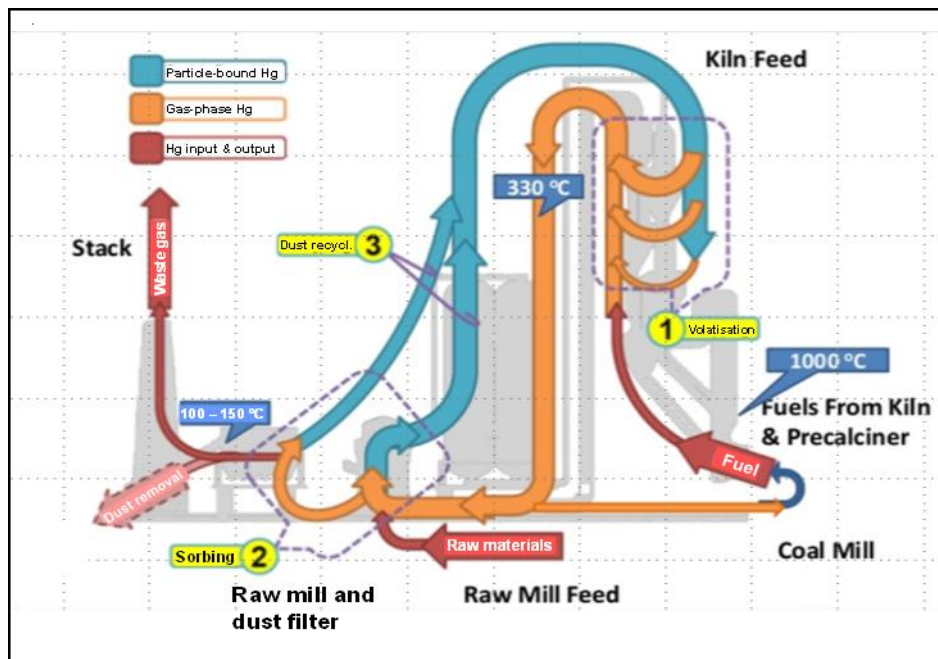

**Figure 6.3: Hg volatilization curves of 4 raw meals (left chart) and of 3 filter dusts (right chart) (AiF, 2008)**

In comparison, the volatilization curves for filter dusts are more narrow (180 °C–400 °C), indicating the presence of elemental mercury, mercury chloride and mercury oxide being adsorbed to the surface of the dust particles (right chart of figure 6.3).

The aforementioned temperature range for the volatilization of mercury species means that most of the mercury present in the raw meal is already volatilized in the first two upper cyclones of the preheater (AiF, 2008; Paone, 2008; Renzoni et al., 2010). Owing to reaction kinetics the volatilization may not be 100 per cent in the preheater but close to it and will be fully completed in the kiln.

It has already been indicated that mercury enriches between the preheater and the dust filter because of the formation of the aforementioned external cycle. The decrease in the gas temperature and the adsorption means that the mercury is removed to a certain extent (mainly depending on the gas temperature) with the filter dust which is recycled to the raw meal to be fed to the preheater where the mercury is volatilized again. Thus, an external mercury cycle is formed, as illustrated in figure 6.4, where both filter dust recycling and its removal are considered.

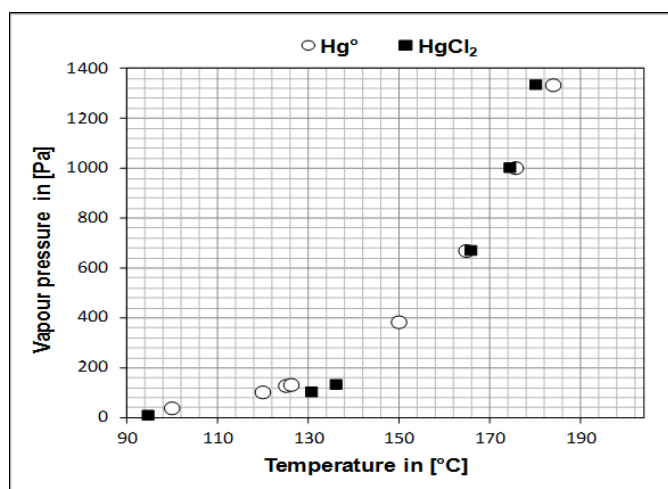

**Figure 6.4: The external mercury cycle in a clinker production plant considering filter dust recycling and removal, based on (Sikkema et al., 2011)**

The gas leaving the preheater usually has a clinker-specific dust content of 5–10 per cent, i.e., 50–100 g of dust per kg of clinker. Modern plants have more efficient upper cyclones. In these cases, the clinker-specific dust content is less than 5 per cent. Directly after the preheater, however, most of the mercury species are still almost completely in the gas phase and not particle-bound. The heat of the waste gas is further recovered by heat exchange, by passing it through the raw mill in order to dry the raw meal. In almost all modern systems with a roller mill, there is no conditioning of the gas before the raw mill; furthermore, water spray is used in the raw mill to control the outlet temperature. In ball mill systems, water spray is sometimes used to control the outlet temperature in the mill, but more often the amount of hot gas taken to the raw mill is adjusted to control the outlet temperature and the balance of the gas is bypassed around the mill, often going through a conditioning tower before the filter (or being combined with the outlet mill gas before going to a filter). Water injection in a conditioning tower is always used in direct (raw-mill-off operation).

The cooling in the raw mill or the conditioning tower leads to the first major shift of the mercury species from the gas phase to the dust particles. A small amount of dust also results from the conditioning tower.

In the raw mill, the heat exchange of the gas takes place and thus, the gas is further cooled down. For the temperature range 0 °C–400 °C, it has been shown that the vapour pressure increases exponentially. This is also true for the temperature range in which the dust filters are operated – about 90 °C–190 °C (figure 6.5).



**Figure 6.5: Dependence of the vapour pressure of Hg° and HgCl₂ on the temperature between 90 °C and 190 °C (Schoenberger, 2015)**

Looking at the curve, it appears logical that the minimization of the waste gas temperature will result in a higher percentage of the particle-bound mercury which can be removed in the dust filter. At optimized removal conditions, the dust particles will be removed to a very high extent. Thus, at waste gas temperatures below 130 °C, the mercury removal efficiency is more than 90 per cent (Kirchartz, 1994, p 79; Oerter, 2007; Hoenig, 2013; ECRA, 2013).

In the compound operating mode (raw mill on), the exhaust gas passes the raw mill in order to dry the raw materials. In the majority of cases, there is usually a bypass of some of the preheater gases around the raw mill and these gases may not be cooled to the same extent before they are mixed with the raw mill exhaust before the filter.

From the silo, with the raw meal, the mercury is returned to the preheater where it volatilizes again and is removed again. Thus, the cycle is formed. Consequently, the silo acts as a big buffer and reservoir and contains the major part of the overall mercury present in the whole system at any given time (see figure 6.4).

In case of the direct operating mode, the gas from the preheater fully passes the conditioning tower, not the raw mill, and is directed to the dust filter; the gas is then not cooled to the same extent compared to the compound operating mode. Accordingly, on the one hand, the preheater dust (with its mercury content) is not diluted with the raw meal and, on the other, the gas (the waste gas) temperature is higher as there is no heat exchange in the raw mill.

The relationship between the outer cycle, the enrichment of mercury, the influence of the waste gas temperature, and the operating modes was investigated and presented in a comprehensive way for the first time in 2001 (Schäfer/Hoenig, 2001). The figures of this publication have been republished a number of times (VDZ Activity Report, 2002; Oerter, 2007; Renzoni et al., 2010; Oerter/Zunzer, 2011; Hoenig, 2013; ECRA, 2013). Figure 6.6 shows one of these graphs for the operation with recycling of the removed filter dust, i.e., over a period of one week the mercury emission curve (values were determined continuously), the related waste gas temperature and the time periods of the compound and direct operation modes.

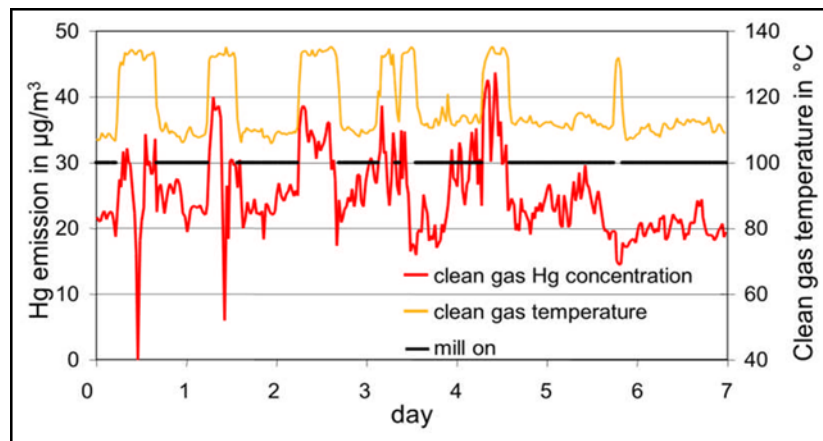

**Figure 6.6: Mercury emissions from a dry rotary kiln for clinker production without filter dust recycling for one week along with indication of the waste gas temperature after the ESP (clean gas temperature) and the time periods with raw mill in operation (mill on), based on Schäfer/Hoenig, 2001, also quoted in VDZ Activity Report, 2002; Oerter, 2007; Renzoni et al., 2010; Oerter/Zunzer, 2011; Hoenig, 2013; ECRA, 2013**

It is clearly demonstrated that the waste gas temperature and emissions are higher in the direct operating mode. This is also due to the enrichment of mercury in the outer cycle during the compound operating mode. The percentage of time in the direct operating mode was about 26 per cent. A shorter share of direct operating mode is often associated with higher enrichment factors. The example from 2001 clearly shows that mercury emissions are higher during the direct operating mode but the difference is less than a factor of two, whereas much higher factors are reported from other plants: up to factor 400 (Linero, 2011).

The reasons for the different factors are:

- The dust content in the gas leaving the preheater: new or retrofitted preheater cyclones lead to lower dust contents and thus, after precipitation at lower temperatures, the mercury concentration of the dust is higher.
- The ratio of compound to direct operating mode: this is between 50:50 and 90:10. At higher ratios, the mercury can enrich more in the outer cycle and thus, the factor for the mercury emissions between compound and direct operating mode increases.
- The waste gas temperature: the lower the waste gas temperature, the lower the vapour pressure and the higher the precipitation of the mercury species on the dust particles.
- The removal efficiency of the dust filter: in former times, the emitted dust concentrations were 50–100 mg/Nm<sup>3</sup>. Since the application of well-designed bag filters, dust concentrations of less than 10, even less



than  $1 \text{ mg/Nm}^3$  are achieved. In combination with low waste gas temperatures, this also contributes to lower mercury emissions.

Another important factor is the removal of filter dust by means of a valve and the extent to which the filter dust is removed. Figure 6.7 shows the scheme of using a valve to remove the filter dust.

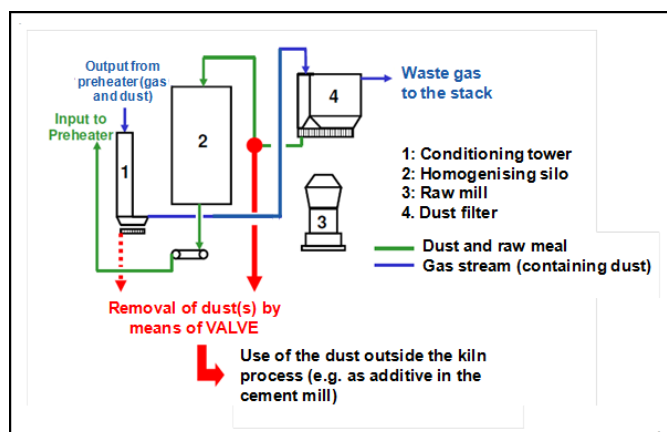

**Figure 6.7: Scheme of the installation of a valve to remove filter dust (Waltisberg, 2013)**

The mercury emission is therefore more constant as indicated in figure 6.8. The indicated time period, however, is relatively short (five days) and the ratio of compound to direct operating mode is high (88:12) at that time (2001).

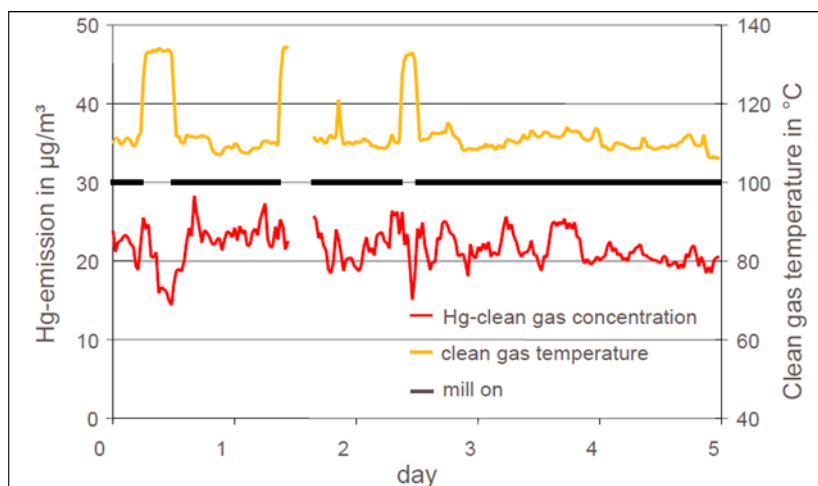

**Figure 6.8: Mercury emissions from a dry rotary kiln for clinker production with filter dust recycling for five days with indication of the waste gas temperature after the ESP (clean gas temperature) and the time periods with raw mill in operation (mill on), based on Schäfer/Hoenig, 2001, also quoted in VDZ Activity Report, 2002; Oerter, 2007; Renzoni et al., 2010; Senior et al., 2010; Oerter/Zunzer, 2011; Hoenig, 2013; ECRA, 2013**

The effect of dust removal is self-evident.

Figure 6.9 shows the calculated impact of the percentage of direct operating mode without dust removal and with dust removal of 100 per cent during direct operating mode on mercury emissions. The difference for the compound operating mode is very small, whereas it is significant for the direct operating mode. If no dust is removed, the mercury emissions to air significantly increase, provided that the removal efficiency of the dust filter is constant. As a consequence of dust removal, the mercury emissions can be reduced by up to 35–40 per cent depending on individual conditions. Figure 6.9, however, provides an example with certain assumptions. In other cases, the reduction can be lower or higher, e.g. 78 per cent as reported elsewhere (Renzoni et al., 2010, p X). Practical cases mainly show reduction rates between 10 and 35 per cent.

The mercury concentration of the filter dust also depends on the individual circumstances. If the mercury removal efficiency of the dust filter is more than 90 per cent, the waste gas temperature around  $100 \text{ }^\circ\text{C}$ , the ratio of compound to direct operating mode about 90:10, and the mercury input level not on a low level, a mercury concentration in the filter dust of up to  $40 \text{ mg/kg}$  can be reached (Renzoni et al., 2010, p XI).



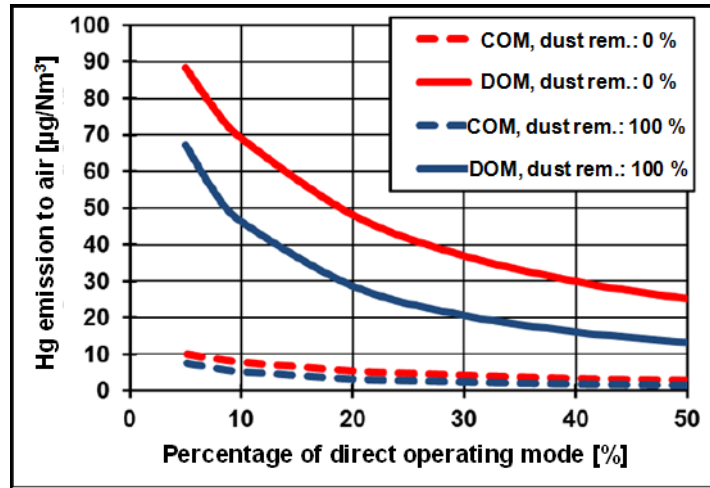

Figure 6.9: Impact of the percentage of direct operating mode without dust removal and with a percentage of dust removal of 100 per cent during direct operating mode.

Legend: COM– compound operating mode; DOM – direct operating mode

### 6.2 Emitted chemical forms of mercury

The transport and deposition of atmospheric mercury depend greatly on whether the mercury is elemental or oxidized (UNEP Hg Assessment, 2013, p. 19). Elementary mercury stays in the atmosphere long enough for it to be transported around the world (the currently estimated lifetime in the atmosphere is between 0.5 and 1.5 years), whereas oxidized and particulate mercury have much shorter lifetimes (from hours to days) and are therefore subject to fast removal by wet or dry deposition (UNEP Hg, 2008, p. 65). Consequently, the gaseous elemental mercury is a global pollutant, whereas oxidized mercury compounds and those associated with particles are deposited regionally (UNEP Hg, 2008, p. 65). As the mercury binding is relevant for capturing the mercury, it is of importance to know which chemical forms are emitted from cement plants.

In figure 6.10 relevant data are compiled from different sources. There are plants where elemental mercury dominates and others where this is the case for oxidized mercury. The ratio of elemental to oxidized mercury emitted depends on the individual conditions, which means that no relationship can be established.

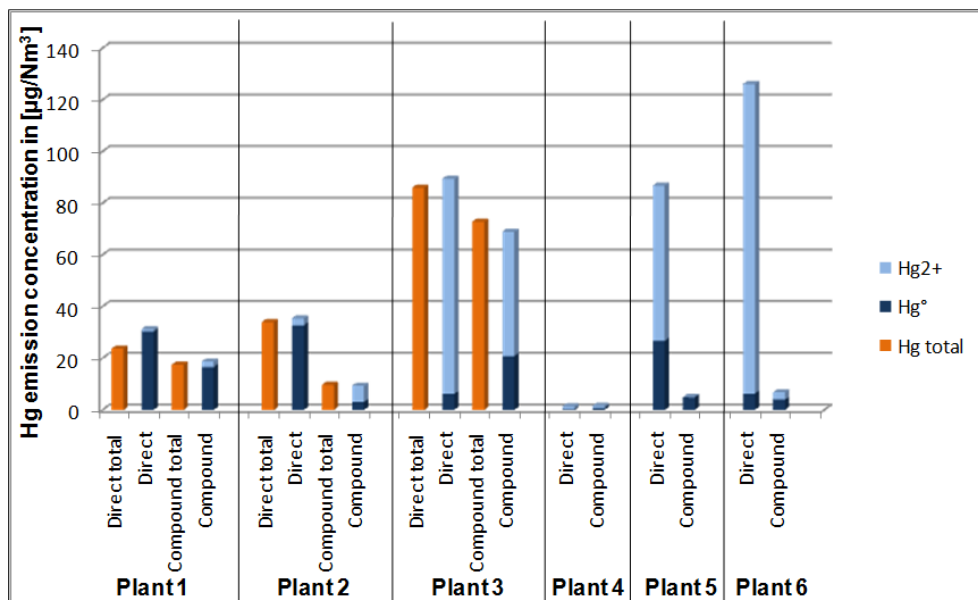

Figure 6.10: Emissions to air of elemental and oxidized mercury according to different sources

Indications for the sources of data:

Plant 1 and plant 2: Oerter/Zunzer, 2011

Plant 3: VDZ Activity Report, 2002

Plant 4: Mlakar et al., 2010

Plant 5 and plant 6: Linero, 2011

## 7 References

- AiF, 2008: Arbeitsgemeinschaft industrieller Forschungsvereinigungen (AiF), AiF-Forschungsvorhaben-Nr. 14547 N: Betriebstechnische Möglichkeiten zur Minderung von Hg-Emissionen an Drehrohranlagen der Zementindustrie (2008)
- Barnett, 2013: Barnett, K. (official of the US-EPA), Final Portland Cement Rule 2013, [http://www.unep.org/chemicalsandwaste/Portals/9/RoundTableMercury\\_6\\_24-13-final.pdf](http://www.unep.org/chemicalsandwaste/Portals/9/RoundTableMercury_6_24-13-final.pdf)
- BREF CLM, 2013: Reference Document on Best Available Techniques in the Cement, Lime and Magnesium Oxide Manufacturing Industries, (2013), online: [http://eippcb.jrc.ec.europa.eu/reference/BREF/CLM\\_Published\\_def.pdf](http://eippcb.jrc.ec.europa.eu/reference/BREF/CLM_Published_def.pdf)
- CEMBUREAU, 1997: BAT for the cement industry, November 1997 / Information for cement and lime BREF 2001
- CRC Handbook, 1976: CRC Handbook of Chemistry and Physics 1976-1977, CRC Press, Inc., 57rd edition (1976), D-185, D-191
- CRC Handbook, 1995: CRC Handbook of Chemistry and Physics 1995–1996, CRC Press, Inc., 76rd edition (1995), 6–77, 6–110
- CRC Handbook, 2012: CRC Handbook of Chemistry and Physics 2012-2013, CRC Press, Taylor&Francis Group Boca Raton, United States, 93rd edition (2012), 6–88, 9–92
- ECRA, 2013: Hoenig, V., Harrass, R., Zunzer, U., Guidance Document on BAT-BEP for Mercury in the Cement Industry, Technical report of the European Cement Research Academy (ecra) on behalf of WBCSD Cement Sustainability Initiative (2013)
- Erhard/Scheuer, 1993: Erhard, H.S., Scheuer, A., Brenntechnik und Wärmewirtschaft, Zement-Kalk-Gips 46 (1993) No. 12, pp. 743–754
- Eriksen et al., 2007: Eriksen, D.Ø., Tokheim, L.-A., Eriksen, T.A., Meyer, J., Qvenild, C., Assessment of mercury emissions at Norcem’s cement kiln by use of 203Hg-tracer, Journal of Radioanalytical and Nuclear Chemistry 273 (2007) No. 3, pp. 739–745
- Hoenig, 2013: Hoenig, V., Sources of mercury, behavior in cement process and abatement options, Presentation at the event “Cement Industry Sector Partnership on Mercury, Partnership Launch Meeting” of European Cement Research Academy on 19 June 2013, [http://www.unep.org/hazardoussubstances/Portals/9/ECRA\\_WBCSD-CESI%20Mercury\\_20130618\\_upload.pdf](http://www.unep.org/hazardoussubstances/Portals/9/ECRA_WBCSD-CESI%20Mercury_20130618_upload.pdf)
- Holleman-Wiberg, 1985: Holleman, A.F., Wiberg, E., Lehrbuch der Anorganischen Chemie, 91.-100. Verbesserte und stark erweiterte Auflage, Walter de Gruyter, Berlin/New York (1985), pp. 1042–1049
- Kirchartz, 1994: Kirchartz, B., Reaktion und Abscheidung von Spurenelementen beim Brennen des Zementklinkers, VDZ-Schriftenreihe der Zementindustrie, (1994) Heft 56, Verlag Bau + Technik, Düsseldorf, Germany
- Krabbe, 2010: Krabbe, H.-J., Grundlagen zur Chemie des Quecksilbers am Beispiel von Rauchgasreinigungsanlagen, Manuscript of the presentation at the ‘VDI Wissensforum – Messung und Minderung von Quecksilberemissionen’ on 28 April 2010 in Düsseldorf, Germany (2010)
- Lafarge Wössingen, 2015: Lafarge Zement Wössingen GmbH. Wlazbachtal/Germany, personal communication (2015)
- Linero, 2011: Linero, A.A., Synopsis of Mercury Controls at Florida Cement Plants, Manuscript for presentation at the 104th Annual Conference and Exhibition of the Air and Waste Management Association in Orlando, Florida, United States, on 22 June 2011
- Locher, 2000: Locher, F.W., Zement – Grundlagen der Herstellung und Verwendung, Verlag Bau und Technik (2000)
- Martel, 2000: Martel, C., Brennstoff- und lastspezifische Untersuchungen zum Verhalten von Schwermetallen in Kohlenstaubfeuerungen, VDI Fortschritts-Berichte, Reihe 15, Nr. 225 (2000)
- Mlakar et al., 2010: Mlakar, L.T., Horvat, M., Vuk, T., Stergaršek, A., Kotnik, J., Tratnik, J., Fajon, V., Mercury species, mass flows and processes in a cement plant, Fuel 89 (2010) pp. 1936–1945

- Netherlands, 1997: Dutch notes on BAT for the production of cement clinker: Information for cement and lime BREF 2001
- Oerter, 2007: Oerter, M., Influence of raw materials on the emissions of mercury, presentation at the seminar of the European Cement Research Academy (ecra) on 26 April 2007
- Oerter/Zunzer, 2011: Oerter, M., Zunzer, U., Messung und Minderung von Quecksilber in der Zementindustrie, manuscript and presentation at the VDI Fachkonferenz „Messung und Minderung von Quecksilber-Emissionen“ on 13 April 2011
- Paone, 2008: Paone, P., Heavy metals in the cement industry: A look at volatile cycles and simple mitigation techniques, <http://www.asocem.org.pe/bivi/sa/dit/icem/01-04-2008.pdf>
- Paone, 2009: Paone, P., Mercury reduction technologies for cement production, 7th Colloquium of Managers and Technicians of Cement Plants – “Development, innovation and sustainability: the three cornerstones of cement industry” in Malaga, Spain, in November 2009
- Permit Cementa AB, 2007: Permit from Stockholms Tingsrätt, M 26737-05, issued to Cementa AB, Slite, in 2007
- Renzoni et al., 2010: Renzoni, R., Ullrich, C., Belboom, S., Germain, A., Mercury in the Cement Industry, Report of the University of Liège independently commissioned by CEMBUREAU (2010), online: [www.unep.org/hazardoussubstances/Portals/9/Mercury/A\\_Inventories/CEMENT%20Industry%20-%20Hg%20report%20CEMBUREAU%20April%202010.pdf](http://www.unep.org/hazardoussubstances/Portals/9/Mercury/A_Inventories/CEMENT%20Industry%20-%20Hg%20report%20CEMBUREAU%20April%202010.pdf)
- SC BAT Cement, 2008: Secretariat of the Stockholm Convention on Persistent Organic Pollutants, Guidelines on Best Available Techniques and provisional Guidance on Best Environmental Practices relevant to Article 5 and Annex C of the Stockholm Convention on Persistent Organic Pollutants, Section V.B. – Part II Source category (b): Cement kilns firing hazardous waste (2008)
- Schoenberger, 2009: Schoenberger, H., Integrated pollution prevention and control in large industrial installations on the basis of best available techniques – The Sevilla Process, *Journal of Cleaner Production* 17 (2009) pp. 1526–1529
- Schoenberger, 2015: Schoenberger H., Personal communication, 2015
- Schreiber et al., 2005: Schreiber, R.J., Kellet, C.D., Joshi, N., Inherent Mercury Controls Within the Portland Cement Kiln System, Research & Development Information, Skokie, Illinois, United States, Portland Cement Association, Serial No. 2841 (2005)
- Schäfer/Hoenig, 2001: Schäfer, S., Hoenig, V., Operational factors affecting the mercury emissions from rotary kilns in the cement industry, *Zement Kalk Gips* 54 (2001) No. 11, pp. 591–601
- Schäfer/Hoenig, 2002: Schäfer, S., Hoenig, V., Effects of process technology on the behaviour of mercury in the clinker burning process: Technical Field 6: Sustainability and cement production; Presentation slides and documentation in: *Process Technology of Cement Manufacturing: VDZ Congress 23-27 September 2002 in Düsseldorf, Germany*, Verein Deutscher Zementwerke (VDZ) (Hrsg.), Verlag Bau+Technik (2003) pp. 484–488
- Sikkema et al., 2011: Sikkema, J.K., Alleman, J.E., Ong, S.K., Wheelock, T.D., Mercury regulation, fate, transport, transformation, and abatement within cement manufacturing facilities: Review, *Science of the Total Environment* 409 (2011) pp. 4167–4178
- Sprung, 1988: Sprung, S., Spurenelemente, *Zement-Kalk-Gips* 41 (1988) No. 5, pp. 251–257
- Ullmann's, 1986: Locher, F.W.; Kropp, J., Cement and Concrete, in Ullmann's Encyclopedia of Industrial Chemistry, 5th ed., Vol. A 5 (1986) pp. 489–537
- UNEP Hg, 2008: UNEP, Technical Background Report to the Global Atmospheric Mercury Assessment (2008),
- UNEP Hg Assessment, 2013: UNEP, Global Mercury Assessment: Sources, emissions, releases, and environmental transport (2013), <http://www.unep.org/PDF/PressReleases/GlobalMercuryAssessment2013.pdf>
- US Cement, 2007: USEPA, Letter from F.L Steitman, Vice President, Environmental Affairs, Ash Grove Cement Company to Keith Barnett, SSPD/USEPA. October 1, 2007 accessed at [www.regulations.gov](http://www.regulations.gov), [EPA-HQ-OAR-202-0051-3371]

US Cement, 2010: USEPA, Summary of Environmental and Cost Impacts for Final Portland Cement NESHAP and NSPS, 6 August 2010 available online at [http://www.epa.gov/ttn/atw/pcem/summary\\_impacts.pdf](http://www.epa.gov/ttn/atw/pcem/summary_impacts.pdf)

VDZ Activity Report, 2002: Verein deutscher Zementwerke e.V. (VDZ), Activity Report 1999-2001 (2002)

Waltisberg, 2013: Waltisberg, J., personal communications (2013)

Weisweiler/Keller, 1992: Weisweiler, W.; Keller, A., Zur Problematik gasförmiger Quecksilber-Emissionen aus Zementwerken, Zement-Kalk-Gips (45 (1992) No. 10, pp. 529–532

Zheng, 2011: Zheng Y., Mercury Removal from Cement Plants by Sorbent Injection upstream of a Pulse Jet Fabric Filter, PhD Thesis at the Technical University of Denmark (2011), <http://wwwx.dtu.dk/upload/kt-chec/phd%20thesis,%20yuanjing%20zheng,%20endelig%20version,%20klar%20til%20print.pdf> (accessed 23 January 2014)

Zheng et al., 2012: Zheng, Y.; Jensen, A.D.; Windelin, C.; Jensen, F., Review of technologies for mercury removal from flue gas from cement production processes, Progress in Energy and Combustion Science 38 (2012) pp. 599–629

---